	GLOBAL STANDARD	Page 1 of 57
	HV CIRCUIT-BREAKERS	GSH001 Rev. 02 03/08/2017

HV CIRCUIT-BREAKERS

Countries' I&N	Elaborated by
Brazil	V. Galvao, Vanderlei Robadey Carvalho
Chile	H. C. Rother Salazar, Manuel Alejandro Gutierrez Toro
Colombia	C. A. Rincon Alvarez, Jose H. Gomez Cuevas
Iberia	Oscar Izquierdo
Italy	Stefano Magistroni
Peru	Roberto L. Sanchez Vargas, Luis Auqui Fernandez
Romania	M. Domnicu

	Elaborated by	Verified by	Approved by
Solution Development Center	Oscar Izquierdo	C. Llovich Badia	Juan Gonzalez Lara
Global I&N – NT/NCS	-	JM. Rey Sanchez	F. Giammanco

This document is intellectual property of Enel SpA; reproduction or distribution of its contents in any way or by any means whatsoever is subject to the prior approval of the above mentioned company which will safeguard its rights under the civil and penal codes.

Revision	Data	List of modifications
00	26/07/2013	First emission
01	09/02/2017	3.1.3 Add reference laws for Spain 3.2.2.2 Added specific standards for Spain 4.2.3. Seismic qualification level of Codensa 6.5.1.2. Added specific requirement for Control Box for Italy 6.5.1.3 Added specific requirement for Control Box for Spain 6.6.1 Modification in bushing terminations Latam 6.8.1. Added specific requirement for Endesa 7.1.1.1. Added specific requirement for Endesa ANNEX B: Added to note 7 for Spain. 9.2.2 Added 18) Only for Endesa Distribución ANNEX C.1. Electrical scheme Endesa changed heating circuit ANNEX C.3. Electrical scheme for Ampla changed ANNEX C.2. Electrical scheme for Enel changed
02	03/08/2017	Editorial revision: Modification of the cover format 3.2.2.4 PVR001 replaced with PVR006. 8.3.2 Added: The density meters verification can be also performed using SF6, if precautions are taken to prevent SF6 dispersion in the environment. Annex B – Table 2, 3 and 4 modifications

	GLOBAL STANDARD	Page 2 of 57
	HV CIRCUIT-BREAKERS	GSH001 Rev. 02 03/08/2017

INDEX

3.1	Laws	6
3.1.1	Latam.....	6
3.1.2	Italy.....	6
3.1.3	Spain.....	6
3.1.4	All European countries.....	6
3.2	Standards	7
3.2.1	Common standards.....	7
3.2.2	Specific standards.....	8
4.1	General service conditions	8
4.2	Specific service conditions	9
4.2.1	Colombia (Codensa).....	9
4.2.2	Romania (Enel Distributie).....	9
4.2.3	Seismic qualification level.....	9
6.1	General characteristics	10
6.2	Insulators	11
6.3	Additional requirements for vacuum CBs	11
6.4	Additional requirements for gas CBs	11
6.4.1	Additional requirements for SF6 gas CBs.....	11
6.4.2	Additional requirements for non-fluorinated greenhouse gases CBs.....	12
6.4.3	Gas (SF6 or non-fluorinated greenhouse gases) density control.....	12
6.4.4	Overpressure safety devices.....	12
6.4.5	Gas filling/replenishment device (<i>Optional</i>).....	13
6.5	Control Box and Operating Device Box(es)	13
6.5.1	Control Box.....	13
6.5.2	Operating Device Box(es).....	15
6.5.3	Nameplates.....	15
6.6	HV terminals	16
6.6.1	Latam.....	16
6.6.2	Endesa Distribución.....	16
6.6.3	Enel Distributie and Enel Distribuzione.....	16
6.7	Grounding	16
6.8	Anti-condensation circuit	16
6.8.1	Endesa specific requirements.....	17
6.9	Protective treatments	17
6.9.1	Latam specific requirements.....	17

	GLOBAL STANDARD	Page 3 of 57
	HV CIRCUIT-BREAKERS	GSH001 Rev. 02 03/08/2017

7.1	Operating Devices	17
7.1.1	General requirements	17
7.1.2	Release drive circuits.....	18
7.1.3	Interlocking devices	20
7.2	Electric schemes, controls and signalizations	21
7.2.1	General requirements	21
7.2.2	Latam specific requirements.....	21
7.2.3	Endesa Distribucion specific requirements	21
7.2.4	Enel Distributie and Enel Distribuzione specific requirements	21
8.1	General information.....	23
8.2	Type tests.....	23
8.2.1	Visual inspection	23
8.2.2	Dielectric tests.....	23
8.2.3	Radio interference voltage (r.i.v.) tests	23
8.2.4	Measurement of the resistance of the main circuit.....	23
8.2.5	Temperature-rise tests.....	23
8.2.6	Short-time withstand current and peak withstand current tests.....	23
8.2.7	Verification of the degree of protection	23
8.2.8	Tightness tests.....	23
8.2.9	Electromagnetic compatibility (EMC) tests	24
8.2.10	Additional tests on auxiliary and control circuits	24
8.2.11	Mechanical and environmental tests	24
8.2.12	Short-circuit current making and breaking tests	24
8.2.13	Critical current tests	24
8.2.14	Single-phase and double-earth fault tests	24
8.2.15	Short-line fault tests	25
8.2.16	Out-of-phase making and breaking tests.....	25
8.2.17	Capacitive current switching tests.....	25
8.2.18	X-radiation test procedure for vacuum interrupters.....	25
8.2.19	Seismic qualification.....	25
8.2.20	Protective treatments	25
8.2.21	Tests on insulators	25
8.2.22	Specific type tests	25
8.3	Routine tests.....	25
8.3.1	Dielectric test on the main circuit	25
8.3.2	Tests on auxiliary and control circuits.....	25
8.3.3	Measurement of the resistance of the main circuit.....	26
8.3.4	Tightness test	26
8.3.5	Design and visual checks	26
8.3.6	Mechanical operating tests.....	26

	GLOBAL STANDARD	Page 4 of 57
	HV CIRCUIT-BREAKERS	GSH001 Rev. 02 03/08/2017

8.3.7	Protective treatments	26
8.3.8	Specific routine tests	26
8.4	Commissioning tests	26
8.4.1	Visual inspection, general checks and functionality test of the auxiliary and control circuits.....	27
8.4.2	Mechanical Operating Tests.....	27
8.4.3	Dielectric tests to the auxiliary and control circuits.....	27
8.4.4	Measurement of resistance to the main circuit.....	27
8.4.5	Tightness test	27
9.1	Tender’s technical documentation	28
9.2	Conformity assessment	28
9.2.1	Conformity assessment process.....	28
9.2.2	Conformity assessment documentation	28
9.3	Packaging, transport, storage and installation/testing	29
ANNEX A	29
ANNEX B	30
ANNEX C	34
ANNEX D	56

	GLOBAL STANDARD	Page 5 of 57
	HV CIRCUIT-BREAKERS	GSH001 Rev. 02 03/08/2017

1 SCOPE

Scope of this document is to provide technical requirements for the supply of three-poles Alternating Current Circuit-Breakers with rated voltage from 72,5 kV to 245 kV to be used in Primary Substations of the Enel Group Distribution companies, listed below:

- Ampla (Brazil)
- Chilectra (Chile)
- Codensa (Colombia)
- Coelce (Brazil)
- Edelnor (Perú)
- Edesur (Argentine)
- Endesa Distribución Eléctrica (Spain)
- Enel Distributie Banat (Romania)
- Enel Distributie Dobrogea (Romania)
- Enel Distributie Muntenia (Romania)
- Enel Distribuzione (Italy)

Note: the indication "Latam" refers to the Enel Group Distribution companies in South America.

Alternating Current Circuit-Breakers (hereinafter CBs) are SF6 insulated (in alternative, non-fluorinated greenhouse gases and vacuum circuit breakers are also acceptable), for outdoor installations in Primary Substations.

Some requirements are applicable only to one or more companies, therefore, depending on the destination of the CBs, the supplied equipment shall comply these specific requirements.

2 COMPONENTS LIST

The following CBs are covered by this global standard:

	GLOBAL STANDARD	Page 6 of 57
	HV CIRCUIT-BREAKERS	GSH001 Rev. 02 03/08/2017

Type code	Rated voltage U_r (kV)	Rated normal current I_r (A)	Rated short-circuit breaking current I_{sc} (kA)	Type of operation
GSH001/1	72,5	2000	31,5	Three-pole
GSH001/2	72,5	2000	40	Three-pole
GSH001/3	145	2000	40	Single-pole
GSH001/4	145	2000	40	Three-pole
GSH001/5	145	3150	40	Three-pole
GSH001/6	145	3150	50	Three-pole
GSH001/7	170	2000	40	Single-pole
GSH001/8	170	2000	40	Three-pole
GSH001/9	245	2000	40	Single-pole
GSH001/10	245	2000	40	Three-pole
GSH001/11	245	3150	40	Single-pole
GSH001/12	245	3150	40	Three-pole

For local components codification see annex A.

3 REFERENCE LAWS AND STANDARDS

3.1 Laws

3.1.1 Latam

3.1.1.1 *Brasil*

NR-10 - segurança em instalações e serviços em eletricidade

3.1.2 Italy

D.M. 1/12/1980 and subsequent modification D.M. 10/9/1981 *“Disciplina dei contenitori a pressione di gas con membrature miste di materiale isolante e di materiale metallico, contenenti parti attive di apparecchiature elettriche”*.

3.1.3 Spain

Real Decreto Riesgo Eléctrico 614/2001

Reglamento Electrotécnico para Baja Tensión, Real Decreto 842/2002.

Reglamento de puntos de Medida Real Decreto 1110/2007.

Reglamento sobre condiciones técnicas y garantías de seguridad en instalaciones eléctricas de alta tensión, Real Decreto 337/2014.

3.1.4 All European countries

Commission Regulation (EC) 1494/2007 of 17 December 2007 (form of labels and additional labelling requirements as regards products and equipment containing certain fluorinated greenhouse gases).

	GLOBAL STANDARD	Page 7 of 57
	HV CIRCUIT-BREAKERS	GSH001 Rev. 02 03/08/2017

3.2 Standards

3.2.1 Common standards

The below listed reference documents shall be intended in the in-force edition at the contract date (amendments included).

For Latin America destinations the reference standard are the IEC/ISO, whilst for Europe destinations the reference standard are the correspondent European standards (EN).

IEC 62271-1	High-voltage switchgear and controlgear - Part 1: Common specifications
IEC 62271-100	High-voltage switchgear and controlgear – Part 100: Alternating current circuit-breakers
IEC/TR 62271-300	High-voltage switchgear and controlgear - Part 300: Seismic qualification of alternating current circuit-breakers
IEC/TR 62271-301	High-voltage switchgear and controlgear – Part 301: Dimensional standardization of high-voltage terminals
CLC/TR 62271-303	High-voltage switchgear and controlgear - Part 303: Use and handling of sulphur hexafluoride (SF6)
IEC 60376	Specification of technical grade sulfur hexafluoride (SF6) for use in electrical equipment
IEC 60073	Basic and safety principles for man-machine interface, marking and identification – Coding principles for indicators and actuators
IEC 60447	Basic and safety principles for man-machine interface, marking and identification - Actuating principles
IEC 61936-1	Power installations exceeding 1 kV a.c. - Part 1: Common rules
IEC/TS 60815-1	Selection and dimensioning of high-voltage insulators intended for use in polluted conditions – Part 1: Definitions, information and general principles
IEC/TS 60815-2	Selection and dimensioning of high-voltage insulators intended for use in polluted conditions – Part 2: Ceramic and glass insulators for a.c. systems
IEC/TS 60815-3	Selection and dimensioning of high-voltage insulators intended for use in polluted conditions – Part 3: Polymer insulators for a.c. systems
IEC 62155	Hollow pressurized and unpressurized ceramic and glass insulators for use in electrical equipment with rated voltage greater than 1000 V
IEC 61462	Composite hollow insulators – Pressurized and unpressurized insulators for use in electrical equipment with rated voltage greater than 1000 V – Definitions, test methods, acceptance criteria and design recommendations
IEC 60332-3-24	Tests on electric and optical fibre cables under fire conditions – Part 3-24: Test for vertical flame spread of vertically-mounted bunched wires or cables - Category C
IEC 60947-7-1	Low-voltage switchgear and controlgear – Part 7-1: Ancillary equipment - Terminal blocks for copper conductors
IEC 60947-7-2	Low-voltage switchgear and controlgear – Part 7-2: Ancillary equipment - Protective conductor terminal blocks for copper conductors
IEC 60068-2-17	Environmental testing – Part 2: Tests – Test Q: Sealing
ISO 1461	Hot dip galvanized coatings on fabricated iron and steel articles-Specifications and test methods

	GLOBAL STANDARD	Page 8 of 57
	HV CIRCUIT-BREAKERS	GSH001 Rev. 02 03/08/2017

ISO 2178	Non-magnetic coatings on magnetic substrates - Measurement of coating thickness -Magnetic method
ISO 4126	Safety devices for protection against excessive pressure
ISO 9223	Corrosion of metals and alloys -- Corrosivity of atmospheres -- Classification, determination and estimation
ISO 12944	Paints and varnishes -- Corrosion protection of steel structures by protective paint systems

3.2.2 Specific standards

3.2.2.1 *Latam*

3.2.2.1.a) *Chilectra*

ETGI-1020 - Especificaciones técnicas generales - Requisitos de diseño sísmico para equipo electrico

3.2.2.2 *Endesa Distribución Eléctrica*

NNM001 – Normas de operación definiciones

NMC001 – Procedimiento para el conexionado de armarios cuadros y paneles

NNC007 – Cables de control multipolares

NZC001 – Procedimiento para la confección de proyectos de control y protección

3.2.2.3 *Enel Distributie*

Prescriptia Energetica PE 101/85 – Normativ pentru construcția instalațiilor electrice de conexiuni și transformare cu tensiuni peste 1 kV

3.2.2.4 *Enel Distribuzione*

CEI 20-22/2 – Prove di incendio su cavi elettrici – Parte 2: Prova di non propagazione dell'incendio

UNI 11144 – Bombole trasportabili per gas – Valvole per bombole per pressioni di esercizio 250 bar – Connessioni: forme e dimensioni

ENEL operative note PVR006 (bar code)

LM 1023 (double cable 245 kV clamp)

LM 1026 (single cable 245 kV clamp)

4 SERVICE CONDITIONS

4.1 General service conditions

Unless otherwise specified, the reference service conditions are the outdoor normal service conditions of IEC 62271-1 (par. 2.1.2).

Minimum ambient air temperature (°C)	-25	
SPS Class (IEC/TS 60815 series)	d (Heavy)	e (Very Heavy)
RUSCD (mm/kV)	43,3	53,7
Ice coating (mm)	10	

	GLOBAL STANDARD	Page 9 of 57
	HV CIRCUIT-BREAKERS	GSH001 Rev. 02 03/08/2017

4.2 Specific service conditions

4.2.1 Colombia (Codensa)

The reference altitude is 2.600 m.

4.2.2 Romania¹ (Enel Distributie)

Minimum ambient air temperature (°C)	-30
Ice coating (mm)	22

4.2.3 Seismic qualification level

Chilectra	ETGI-1020
Codensa	AF3 (IEC/TR 62271-300)
Edelnor	AF5 (IEC/TR 62271-300)
Enel Distributie	AF5 (IEC/TR 62271-300)
Enel Distribuzione	AF5 (IEC/TR 62271-300)

5 TECHNICAL CHARACTERISTICS

In addition to IEC 62271-100, the following requirements are prescribed.

Rated voltage U_r (kV)	72,5	145	170	245
Rated short-duration power-frequency withstand voltage U_d (kV rms):	140	275	325	460
Rated lightning impulse withstand voltage U_p (kVp):	325	650	750	1050
Rated frequency f_r (Hz)	Chilectra, Edesur, Endesa Distribución, Enel Distributie and Enel Distribuzione	50		
	Ampla, Codensa, Coelce and Edelnor	60		
Rated normal current I_r (A)	See table in chapter 2			
Rated short-circuit breaking current I_{sc} (kA)	See table in chapter 2			
First-pole-to-clear factor k_{pp}	1,5 (non-effectively earthed neutral system)			1,3
Rated operating sequence	O - 0,3 s - CO - 1 min - CO ²			

¹ In accordance with Prescriptia Energetica PE 101/85

² This requirement can be verified by mean of type tests performed with O - 0,3 s - CO -3 min - CO operating sequence and a declaration of the manufacturer about the CB compliance with O - 0,3 s - CO - 1 min - CO operating sequence.

	GLOBAL STANDARD	Page 10 of 57
	HV CIRCUIT-BREAKERS	GSH001 Rev. 02 03/08/2017

Maximum break-time (ms)		60			
Circuit breaker class		C2 - E1 - M2			
Rated line-charging breaking current I_l (A)		10	50	63	125
Rated cable-charging breaking current I_c (A)		125	160		250
Rated out-of-phase making and breaking current I_d (kA)		Clause 4.106 of IEC 62271-100			
Degrees of protection provided by enclosures		IP 54 ³			
Rated supply voltage U_a (Vdc)	Enel Distributie and Enel Distribuzione	110			
	Endesa Distribución Eléctrica, Ampla, Coelce, Chilectra, Codensa, Edelnor	125			
	Edesur	220			
d.c. maximum absorbed power (W)		2000			
Undervoltage release (if requested) - d.c. maximum abs. power (W/coil)		100			
Rated supply voltage for anti-condensation circuits (Vac)	Endesa Distribución, Enel Distributie and Enel Distribuzione	230			
	Ampla, Coelce, Chilectra, Edelnor, Edesur	220			
	Codensa	120			
a.c. maximum absorbed power (VA)		250			
Auxiliary contact classes (Table 6 IEC 62271-1)		1			

6 CONSTRUCTION CHARACTERISTIC

6.1 General characteristics

The CBs shall be manufactured in accordance with IEC 62271-100.

The dimensional drawings are in annex B, where are indicated:

- the main CBs binding dimensions;
- the metallic support (3 or 2 uprights, depending on the company);
- the external grounding connections;
- the cable shaft of the civil works.

The support, quoted separately, shall be always supplied when a seismic qualification level is required (see 4.2.3), otherwise it's an optional supply.

³ Applicable also to the Control Box and to the Operating Device Box(es).

	GLOBAL STANDARD	Page 11 of 57
	HV CIRCUIT-BREAKERS	GSH001 Rev. 02 03/08/2017

If interface plates and other accessories are necessary to adapt the support to the civil works, they shall be included in the supply of the support and shall be preliminary approved by Enel Group Distribution companies.

The poles naming shall be A, B, C, from left to right, looking the CB from the side with the main contact position indicators.

The normal use, control and maintenance operations shall be performed with total workers safety.

6.2 Insulators

The insulators could be requested by Enel Group Distribution companies in ceramic or composite materials.

In case of ceramic insulators, they shall be in brown color and compliant with IEC 62155.

In case of composite insulators, they shall be in light grey color and compliant with IEC 61462. The envelope shall be made of silicone rubber, HTV type (High Temperature Vulcanized) or LSR type (Liquid Silicone Rubber) and completely free of EPDM or other organic rubbers.

6.3 Additional requirements for vacuum CBs

The breaking elements shall have an expected life above 30 years.

If an insulation gas is present, the manufacturer shall declare:

- the type of gas used (chemical composition of gas or gas blend) and the rated filling pressure at 20 °C;
- the type of system (closed pressure system or sealed pressure system, in the second case with an expected life above 30 years).

6.4 Additional requirements for gas CBs

6.4.1 Additional requirements for SF6 gas CBs

Generally the dielectric mean for insulation and arc extinction is SF6, with a pressure over the atmospheric one.

The gas SF6 shall comply with IEC 60376 standard. The manufacturer has to provide the necessary instructions for use and handling of SF6, in accordance with Technical Report IEC IEC/TR 62271-303.

In case of single-poles CB's a distinct SF6 circuit and connection for each pole is required.

In case of three-pole CB's the number of SF6 circuits and consequent connections is the following:

CB's rated voltage (kV)	Number of SF6 circuits			
	Latam	Endesa Distribución Eléctrica	Enel Distributie	Enel Distribuzione
72,5	Unique for the 3 poles			
145	Unique for the 3 poles	One for each pole		
170	One for each pole			
245	One for each pole			

Each SF6 circuit shall provide a connection elements (type DILO VK/BG-03/8 or equivalent), with a non-return valve, both for SF6 control device and for gas filling/replenishment, provided by not-losable protection screw taps (located not higher than 1.800 mm from the ground level).

	GLOBAL STANDARD	Page 12 of 57
	HV CIRCUIT-BREAKERS	GSH001 Rev. 02 03/08/2017

The SF6 circuit piping shall be performed using stainless steel or, in alternative, painted copper, in order to reduce the stealing risk.

6.4.2 Additional requirements for non-fluorinated greenhouse gases CBs

In alternative to the SF6, non-fluorinated greenhouse gases are also acceptable.

In case of single-poles CB's a distinct gas circuit and connection for each pole is required.

In case of three-pole CB's the number of gas circuits and consequent connections is the same of SF6 gas CBs (see table in 6.4.1).

Each gas circuit shall provide a connection elements (the manufacturer will propose a suitable type different from the one used for SF6, in order to avoid mistakes), with a non-return valve, both for gas control device and for gas filling/replenishment, provided by not-losable protection screw taps (located not higher than 1.800 mm from the ground level).

6.4.3 Gas (SF6 or non-fluorinated greenhouse gases) density control

The CB is a closed pressure system. The relative leakage rate shall be $Frel \leq 0,5\%$ per year. The value for the time between replenishments shall be at least 10 years.

It shall be possible to perform the gas replenishment with the equipment in service, avoiding the unwanted operation of the gas density control device.

Each gas circuit (1 or 3, see 6.4.1 or 6.4.2) shall have a device for the gas density control.

The alarm threshold calibration has to take into account the leakage rate. The block threshold calibration shall be at least 0,02 MPa lower respect to the alarm threshold.

The gas density control device shall be:

- suitable to work in the provided temperature range;
- located in order to avoid the solar radiation influence on the external temperature measuring;
- insensitive to the vibration produced by the equipments operation;
- manufactured with stainless materials;
- realized in order to allow the functionality verify and the substitution with the poles under pressure;
- with the following scale(s) for a visible indication of gas density level:

Type of scale	Endesa Distribución Eléctrica, Enel Distributie and Enel Distribuzione	Latam
Colored	Mandatory	Mandatory
Graduated	Forbidden	Mandatory

The gas density control device shall provide 2 operating levels with contacts independently adjustable:

- 1st minimum gas density level: alarm (replenishment necessary) with 1 contacts;
- 2nd minimum gas density level: block (to get out of service) with 2 contacts working separately on 2 opening circuits (depending on specific requirements in chapter 7).

The contacts operating tolerance shall be lower than $\pm 1,5\%$ (referring to the full scale) in the provided temperature range; the contacts of each minimum gas density level shall have a difference $\leq 0,005$ MPa between them.

6.4.4 Overpressure safety devices

Safety devices against the internal overpressure is mandatory only in case of ceramic insulators.

The devices shall be compliant with ISO 4126 and shall be properly calibrated over the maximum operating pressure, in order to avoid improper operations.

	GLOBAL STANDARD	Page 13 of 57
	HV CIRCUIT-BREAKERS	GSH001 Rev. 02 03/08/2017

In case of overpressure safety valves operation, the expelled gas shall not run over people around the equipment.

6.4.5 Gas filling/replenishment device (*Optional*)

At request the manufacturer shall supply a device for the gas replenishment.

In case of SF₆, the device shall be provided by female thread connection, W 21,7 x 1/14" (UNI 11144 – only for Enel Distribuzione,) on gas bottle side and DILO VK/BG-03/8 or equivalent on pole junction device side. The device will consist of:

- pressure regulator
- a safety valve (ISO 4126 compliant, calibrated at 8 bar rel);
- a pressure gauge 0÷1 MPa, 0,5 class, minim resolution ± 5 kPa, accompanied with a calibration certificate;
- flexible tube 5 meters long, DN≥8.

In case of non-fluorinated greenhouse gases, the manufacturer will propose a suitable solution compliant, when applicable, with the above mentioned requirements for the SF₆ version.

6.5 Control Box and Operating Device Box(es)

The requested cabinets are the followings:

- a cabinet for control and interface with the remote control system (hereinafter "Control Box")
- cabinet(s) for the operating device (hereinafter "Operating Device Box"), 3 for single-pole CBs, 1 for three-pole CBs.

The Control Box can be physically integrated in the Operating Device Box (in one of the 3 operating device boxes in case of single-pole CBs).

6.5.1 Control Box

The Control Box shall be fixed on the CB support, compatibly with the civil works. The CBs shall be equipped with proper conduits for the connection cables to the substation control system, from the Control Box to the existing cable shaft of the civil works; the minimum dimensions of the conduits shall be 100x50 mm.

All CBs auxiliary and control equipments shall be placed in the Control Box.

In addition to the IP requirement of table at chapter 5, the box protection degree with open doors shall be minimum IP2X.

In addition to the dimensions shown in Annex B, the box base height respect to the ground shall be ≥ 400 mm and all HMI (Human Machine Interface) elements (controls and signalizations) shall be at ≤ 1800 mm.

The box interior shall be accessible from the front by mean of a door provided of handle and lock. The door (simple or double), hinged and equipped with an anti-wind system, shall be provided with a window in order to make visible from outside the signalization lamps. It shall be possible to open the door over 90°.

All accessories (hand-crank, document pocket etc.) shall be accommodated in the internal part of the box door.

All electric equipments components shall be:

- compliant with the respective IEC standards;
- equipped with an identification label indicating the codification used in the functional electric schemes;
- easily accessible for maintenance or substitution operations.

In particular, the extractible ones, plug-in connector included, shall be provided with proper anti-mistake coding.

	GLOBAL STANDARD	Page 14 of 57
	HV CIRCUIT-BREAKERS	GSH001 Rev. 02 03/08/2017

The box internal wiring shall be performed with conductors with adequate section (always $\geq 1\text{mm}^2$), flexible type, compliant with IEC 60332-3-24 and insulated at $U_0/U = 450/750\text{ V}$.

The cable ends shall be provided of pre-insulated compression type terminals, suitable for the clamps where they have to be connected.

The connection cable from the Control Box to the equipments shall be of adequate section ($\geq 1,5\text{ mm}^2$), shielded, flexible, compliant with IEC 60332-3-24 and insulated at $U_0/U = 0,6/1\text{ kV}$.

Inside the Control Box an internal collector (in tin-plated or nickel-plated copper, section $\geq 60\text{ mm}^2$ and with M5 regular interval threaded hole) shall be present for the grounding connection of all cable shields; the manufacturer shall guarantee its effective connection to the CB grounding system.

The entrance of all cables (both CB's cables and control system cables) shall be from the Control Box bottom side, where a removable loophole (in aluminum, with useful dimension of $150 \times 100\text{ mm}$) shall be provided.

The Control Box shall include:

- remote/local selector switch
- control buttons for circuit breaker, with the following colors:

Operation	Chilectra, Codensa, Edelnor, Edesur, Endesa Distribución Eléctrica, Enel Distributie and Enel Distribuzione (according with IEC 60073)	Ampla, Coelce (according with NR10)
Closing	White	White "L" on Red white background
Opening	Black	White "D" on Green white background

- magneto-thermic automatic circuit breakers for the supplies protection (motors, lighting lamp, anti-condensation circuits – fuses are not admitted);
- interface terminal board for substation control system;
- anti-condensation circuit;
- internal lighting lamp, with automatic switching in case of open door;
- only in case of three gas circuits, gas density signalization lamps (for each gas circuit, yellow color about 1st minimum gas density level; red color about 2nd minimum gas density level);
- only in case of three gas circuits, lamps testing button.

The signalization lamps and the internal lighting lamps shall not be incandescent type.

The grounding of a dc supply polarity is not admitted.

The terminal boards shall be made with modular terminals. In particular, the terminals of control system interface terminal board shall have section 4 mm^2 for control, signalization and anti-condensation circuits and section 10 mm^2 for the motors supply circuit.

It shall be provided 2 bridged terminals couples for the anti-condensation circuit and 2 for the motor supply circuit.

If diodes are used for the circuit separations or for the voltage return protection, they shall have inverse voltage $\geq 3\text{ kV}$.

The cable trucking systems for the internal wiring shall have sufficient residual space ($\geq 10\%$ of used volume); the cables shall be anchored in some points on order to avoid their falling.

The cable trunks close to the interface terminal boards shall be used for the control system wiring and cannot be used for the internal wiring.

6.5.1.1 *Latam specific requirements*

The remote/local selector switch shall have auxiliary contacts.

	GLOBAL STANDARD	Page 15 of 57
	HV CIRCUIT-BREAKERS	GSH001 Rev. 02 03/08/2017

The Control Box shall also include an electric socket output (Vac).

About the terminal boards, provision should be made for 20% of free terminals.

The control box shall also include auxiliary switch contacts to indicate CB position. The quantities of auxiliary contacts available (NO-Normally Open or NC-Normally Closed) for the different companies is indicated in Annex C.3.

6.5.1.2 *Enel Distribuzione specific requirements*

In alternative to IEC 60332-3-24, cables compliant with Italian standard CEI 20-22/2 and marked with "CEI 20-22 II" can be accepted.

It's necessary a space in the control box with a DIN bar width 150mm, height 200mm, depth 150mm for a device DV7203 (conversion digital signal in optical)

6.5.1.3 *Endesa specific requirements*

For Endesa the remote/local selector switch and the control buttons for opening and closing are not required in the CB. Please check Annex C.1

6.5.2 Operating Device Box(es)

The operating devices, the CB operation counters (mechanical, four-digits, not-resettable), the auxiliary electric equipments, the auxiliary contacts and the terminal boards (or connectors) shall be located: in a single cabinet for three-pole CBs; in 3 cabinet for single-pole CBs.

Each operating device box shall be equipped with spring loading condition signalization and with main contact position indicators, having the following characteristics:

Position	Chilectra, Codensa, Edelnor, Edesur, Endesa Distribución Eléctrica, Enel Distributie and Enel Distribuzione (according with IEC 60073)	Ampla, Coelce (according with NR10)
Close	Black "I" on white background	White "L" on Red white background
Open	White "O" on black background	White "D" on Green white background

During normal operation, with encloses and doors closed, the main contact position indicators and the spring loading condition signalization shall be visible from ground level.

In order to allow the verification, during maintenance activity, of the unchanged characteristics of the no-load travel curve (see note in 9.2.2-11b), manufacturer shall provide the measuring points, properly machined.

In addition to the IP requirement of table at chapter 5, the box(es) protection degree with open doors or when using hand-crank (to charge CB's springs) shall be minimum IP2X (unless the box can be opened only using tools).

All mechanical organs (included the motion transmission rods for three-pole CBs) shall be enclosed in metallic casings, IP2X, in order to prevent the access to parts in movement (see par. 5.13.1 of IEC 62271-1).

The manufacturer shall provided the instruction for a safety access to mechanical organs.

6.5.2.1 *Latam specific requirements*

The operation counter can be mechanical or electromechanical.

6.5.3 Nameplates

Par. 5.10 of IEC 62271-100 apply, specifying that both CB nameplate and operating devices nameplates shall include:

	GLOBAL STANDARD	Page 16 of 57
	HV CIRCUIT-BREAKERS	GSH001 Rev. 02 03/08/2017

- the optional values;
- the Enel Group type code (see table in chapter 2) and the local components codification (see Annex A).

For traceability purpose, if the Control Box is not integrated in the Operating Device Box(es), in the internal part of the Control Box door shall be located a self-adhesive nameplate with the following information:

- box manufacturer;
- serial number of the Control Box;
- year of construction.

6.5.3.1 *Latam specific requirements*

The self-adhesive nameplate to be located in the internal part of the Control Box door shall also contain the contract number.

6.5.3.2 *European countries specific requirements*

If applicable, an informative nameplate with the sentence “*Contains fluorinated greenhouse gases covered by the Kyoto Protocol*” (in accordance with Commission Regulation (EC) 1494/2007 of 17 December 2007) shall be provided.

6.6 HV terminals

6.6.1 Latam

The HV terminals shall be manufactured with corrosion resistant copper or aluminum alloy, in order to be interfaced with aluminum alloy connectors or clamps.

The terminals shall be rectangular shape with the following dimensions, according to fig. 3 (2x2 hole pattern) or fig. 4 (2x3 hole pattern) of IEC/TR 62271-301:

- Hole diameters \varnothing 14.3mm
- Distance between holes 44.5mm

6.6.2 Endesa Distribución

The HV terminals shall be compliant with fig. 6 (2x4 hole pattern) of IEC/TR 62271-301.

6.6.3 Enel Distributie and Enel Distribuzione

The HV terminals shall be realized with corrosion resistant copper or aluminum alloy, in order to be interfaced with aluminum alloy clamps.

For CBs up to 170 kV the HV terminals shall have \varnothing 40 \pm 0,25 X 80 min (mm) (fig. 1 of IEC/TR 62271-301) dimensions.

For 245 kV CBs the HV terminals shall be suitable to be interfaced with standardized Enel clamps LM 1023 (double cable) and LM 1026 (single cable).

6.7 Grounding

The manufacturer shall ensure the equi-potentiality between all parts forming the equipment.

At the base of each support upright two grounding points shall be provided, equipped with M12 stainless steel bolts (included in the supply).

If interface plates are necessary to adapt the support to the civil works, they shall be designed taking into account the position of the external grounding connections (see Annex B).

6.8 Anti-condensation circuit

Inside all boxes a proper anti-condensation system shall be provided in order to prevent humidity damages and to ensure a proper air replacement.

	GLOBAL STANDARD	Page 17 of 57
	HV CIRCUIT-BREAKERS	GSH001 Rev. 02 03/08/2017

The anti-condensation circuit, controlled by a thermostat with fixed regulation at 25 °C (box internal temperature), shall be unique for the overall equipment, supplied in a.c. (see table in chapter 5 for the supply rated voltage) and protected with a magneto-thermic automatic circuit breaker.

The heating elements shall be preferably connected in series in order to have the circuit opening in case of failure of an element; a minimum current sensor shall detect and signal the anomaly.

In parallel connection case, the manufacturer shall assure a correct fault detection and distance anomaly signaling in case of failure of an element, properly evaluating the tolerances of the supply voltage and of the components resistance.

6.8.1 Endesa specific requirements

For the heating system, the minimum current sensor is not necessary. See Annex C.1.

6.9 Protective treatments

All external surfaces shall have an effective and enduring anti-corrosion protection.

All iron parts (e.g. support, Control Box, Operating Device Box(es), bolts etc.) shall be in non-corrosive material or hot dip galvanized in compliance with ISO 1461. All processing shall be completed before the protective treatments.

Protective treatments alternative to the hot dip galvanization could be accepted if the manufacturer prove its fitness.

The metallic elements in contact between them shall be designed in order to avoid corrosion due to humidity galvanic effect.

6.9.1 Latam specific requirements

In Brazil (Ampla y Coelce) there is atmospheric corrosive environments "Very High" (C5- ISO 9223 and ISO 12944). Thus, in case of hot dip galvanized steel for control box or cabinet, it will apply a system of painting with ink wash primer, primer and finishing, with a minimum total thickness of 100 µm.

7 FUNCTIONAL CHARACTERISTIC

7.1 Operating Devices

7.1.1 General requirements

The CB controls shall be realized in order to be managed both remotely and locally. For this purpose a selector switch shall be located in the Control Box for the operation type choice: remote or local (hereinafter "remote/local selector switch"⁴).

In "remote" position the remote controls are enabled and the local controls are disabled. In "local" position the enabling are the opposite.

⁴ the words "remote" and "local" have to be translated in all documents as:

- Italian language: "Servizio" (S) and "Prova" (P)
- Spanish language: "Remoto" and "Local"
- Romanian language: "In functiune" and "Probe"
- Portuguese language: "Remoto" and "Local"

	GLOBAL STANDARD	Page 18 of 57
	HV CIRCUIT-BREAKERS	GSH001 Rev. 02 03/08/2017

The switch operation shall not cause unwanted equipment operations.

The local operation of circuit breakers (three-pole operations, it shall not be possible to operate locally single-pole operations) shall be controlled by the push-buttons located in the Control Box (see 6.5.1).

During normal operation temporary block signalizations shall not be sent to the control system.

The CBs operating device shall be spring type, three-pole or single-pole type.

The operating device energy storage shall be normally made by mean of a d.c. electric motor (see table in chapter 5 for the supply rated voltage); when necessary it shall be possible to restore manually the operating device energy, with a maximum effort below 250 N. The manual device shall exclude the motor operation, or in alternative shall be designed excluding its possible movement in case of unexpected spring operation.

All releases, both for closing and for opening, shall not work with a signal duration ≤ 3 ms.

The CBs operating device shall be able to perform the following cycles⁵:

- with motor working:
 - O – 0,3 s – CO – 1 min – CO with CB closed and opening and closing springs charged;
- with motor not working:
 - O – 0,3 s – CO with CB closed and opening and closing springs charged;
 - CO with CB open and closing springs charged;
 - O with CB closed and opening springs charged.

The single-pole CBs shall be equipped with a device for the signalization of poles not being in the same position (closed or open).

7.1.1.1 *Endesa specific requirements*

The selector is located in a centralized control box, for this reason it's not necessary the local-manual-remote selector in the control box. For the same reason the open-close buttons are not necessary. See Annex C.1.

7.1.2 Release drive circuits

7.1.2.1 *General requirements*

The release drive circuits typologies are (see specific requirements for details):

- drive circuit of shunt closing release;
- drive circuit of shunt opening release;
- drive circuit of under-voltage release (if required in local requirements sections).

It shall be possible to request the CB opening acting both on a single circuit at a time and concurrently on any combination of the different opening circuits.

If during an operation an opposite operation request is received, the consent to the last operation shall be given only after the completion of on-going operation (in this case, only for single-pole CBs, the discrepancy between poles can be over the required limits).

⁵ with the CB closed the opening springs shall be always charged.

	GLOBAL STANDARD	Page 19 of 57
	HV CIRCUIT-BREAKERS	GSH001 Rev. 02 03/08/2017

The closing circuit shall be equipped with anti-pumping devices (1 for three-pole CBs and 3 for single-pole CBs) in order to inhibit further closing operations after the first one if an opening occurs during the initial closing request.

The main contacts position shall be assured stably and surely in the open and closed position. The CBs shall not operate in case of accidental auxiliary circuits supply interruption or in case of supply restore (excluding the drive circuit of under-voltage release).

7.1.2.2 *Latam specific requirements*

The circuit breaker will be provided with two opening and independent coils.

Function trip circuit supervision: it shall be possible, if not supplied with the CB, to install a monitoring open circuit device, which aim to explore safely and permanently in the continuity of such circuits open, regardless of the CB position (open or closed), so that the open operation results in all cases satisfactory.

It shall be possible to perform the CB closing and opening (when H.V. and d.c. supplies are off, i.e. due to a fault) by means of (safety located) hand operated levers or buttons.

For Ampla: capacitive source for circuit breaker opening.

Other requirements for different companies are in Annex C.3.

7.1.2.3 *Endesa Distribución specific requirements*

The circuit breaker will be provided with two opening and independent coils.

It shall be possible to perform the CB closing and opening (when H.V. and d.c. supplies are off, i.e. due to a fault) by means of (safety located) hand operated levers or buttons.

7.1.2.4 *Enel Distributie and Enel Distribuzione specific requirements*

The three-pole CBs shall be provided with the following drive circuits:

- a) N° 1 drive circuit of shunt closing release;
- b) N° 1 drive circuit of shunt opening release;
- c) N° 1 drive circuit of under-voltage release.

The single-pole CBs shall be provided with the following drive circuits:

- a) N° 1 drive circuit of shunt closing release;
- b) N° 2 drive circuits of shunt opening release;
- c) N° 1 drive circuit of under-voltage release.

The three-pole CBs can be installed only in transformer's bay.

The single-pole CB can be installed both in line's bay and in transformer's bay, selecting the service type by mean of a selector switch named "43LT" included in the Control Box: in case of transformer's bay use the selector switch will be in "T" position; in case of line's bay use the selector switch will usually be in "L" position (in case of line bays in substations looking out to substations with HV SF6 GIS, it shall be used single-pole CBs with the L/T selector switch in "T" position).

The single-pole CBs shall be provided of a congruency check (and consequent alarm) between the L/T selector switch position and the under-voltage release manual lock/unlock devices position.

The three-pole CBs shall be provided of an alarm signalization in case of under-voltage release manually locked.

It shall be possible to manually lock/unlock the under-voltage release by mean of a device provided of the "bloccato"/"sbloccato" indication. This device shall be located externally to the Operating Device Box and shall be maneuverable from the ground level. It shall be possible to operate this device with the CB in service and without causing an unwanted opening.

In the functional scheme it shall be provided the locked under-voltage release signalization.

	GLOBAL STANDARD	Page 20 of 57
	HV CIRCUIT-BREAKERS	GSH001 Rev. 02 03/08/2017

Under-voltage releases consisting of energy storage systems (for example capacitors) are not admitted.

The CB closing consensus shall be interdict in case of under-voltage release drive circuit not supplied or locked (only if “43LT” selector is in “T” position, see flowcharts in annex C.2).

7.1.3 Interlocking devices

7.1.3.1 General requirements

All operations shall be dependent to the internal CB interlockings.

The following interlocking circuits shall be provided, depending on the monitored values (springs status, gas pressure etc.):

- reclosing
- closing
- opening or, if required, automatic opening with open position blocking.

Further details are in the specific requirements.

7.1.3.2 Latam specific requirements

For the interlocking requirements refer to the annex C.3.

7.1.3.3 Endesa Distribución specific requirements

For the interlocking requirements refer to the annex C.1.

7.1.3.4 Enel Distributie and Enel Distribuzione specific requirements

For the interlocking devices and for the automatic opening with open position blocking, IEC 62271-100 applies with the clarifications in the following.

The following interlockings are requested:

- a) Closing block (enabled in both positions of the remote/local selector switch)
- b) Opening block (enabled in both positions of the remote/local selector switch) or in alternative automatic opening with open position blocking (enabled only in remote position of the remote/local selector switch)

The refresh shall occur automatically only after the ending of the condition causing the block.

Both during normal CB working and during operations shall not be sent to the control system temporary block signalizations.

7.1.3.4.a) Closing block

The closing block shall be activated if one of the following conditions occur:

- a) 2nd minimum gas density level (only in case of gas CBs);
- b) discharged closing springs (at least one of the three springs in case of single-pole CBs).

In case of three-pole CBs or single-pole CBs with L/T selector switch in “T” position, the closing block shall be activated also in the following conditions:

- a) drive circuit of under-voltage release not supplied;
- b) under-voltage release mechanically locked (at least one of the three releases in case of single-pole CBs).

In case of single-pole CBs with L/T selector switch in “L” position, the closing block shall be activated also in the following conditions:

- a) at least one of the three under-voltage releases mechanically locked.

7.1.3.4.b) Opening block

In case of single-pole gas CBs with L/T selector switch in “L” position, the opening block shall be activated in case of 2nd minimum gas density level intervention.

	GLOBAL STANDARD	Page 21 of 57
	HV CIRCUIT-BREAKERS	GSH001 Rev. 02 03/08/2017

7.1.3.4.c) *Automatic opening with open position blocking*

In case of three-pole gas CBs or single-pole gas CBs with L/T selector switch in “T” position, the automatic opening with open position blocking shall be activated in case of 2nd minimum gas density level intervention.

The automatic openings operate in the same time:

- a) for three-pole CBs, on the shunt release and on the under-voltage release;
- b) for single-pole CBs, only on the shunt releases.

7.2 Electric schemes, controls and signalizations

7.2.1 General requirements

The electric schemes shall:

- a) be represented in the reference conventional conditions:
 - a.1) CB in open position;
 - a.2) absence of a.c. and d.c. auxiliary supplies;
 - a.3) gas absence (only for gas insulated CBs – SF6 or non-fluorinated greenhouse gases);
 - a.4) closing springs discharged;
 - a.5) remote/local selector switch in remote position;
 - a.6) in case of micro-switches with the state dependent on the opening/closing of the boxes/carters of operating devices, they shall be represented disable (that is with boxes/carters open).
- b) report, only for gas CBs, the following pressures values at 20°C (relative values):
 - b.1) rated filling pressure;
 - b.2) threshold setting pressure of the 1st minimum gas density level (alarm, replenishment necessary);
 - b.3) threshold setting pressure of the 2nd minimum gas density level (block or automatic opening with open position blocking).
- c) contain the functional scheme, all information useful to identify the single wires and cables, the equipments wiring schemes (auxiliary contacts, relays, gas density control devices etc.), the topographic schemes for interconnections between boxes, the topographic schemes about all the electric components in Control box/Operating device box(es), the anti-mistake coding.

Further details are in the specific requirements and in annex C.

7.2.2 Latam specific requirements

The details of the requirements are in the annex C.3.

7.2.3 Endesa Distribucion specific requirements

The details of the requirements are in the annex C.1.

7.2.4 Enel Distributie and Enel Distribuzione specific requirements

7.2.4.1 Electric schemes

The electric schemes are indicatively represented (where applicable in case of vacuum CBs) in Figure 3 (for three-pole CBs), Figure 4 (for 72,5 ÷ 170 kV single-pole CBs) and Figure 5 (for 245 kV single-pole CBs) of Annex C.2. In these figures are also represented the two versions of “E” interface terminal board for substation control system.

Further reference conventional conditions are:

- a) for remote/local selector switch: S/P switch in S position and L/T switch (if present) in L position;

	GLOBAL STANDARD	Page 22 of 57
	HV CIRCUIT-BREAKERS	GSH001 Rev. 02 03/08/2017

- b) unlocked under-voltage release for three-pole CBs;
- c) locked under-voltage releases for single-pole CBs.

7.2.4.2 Controls

The CBs operating logics are represented in the flowcharts in Annex C.2 (where applicable in case of vacuum CBs).

It shall be reported in the terminal board the contacts referred to the following controls:

- a) single-pole CBs
 - a.1) drive circuit of shunt closing release control (CH-ABC)
 - a.2) 1st drive circuit of shunt opening release control (1° AP-A; 1°AP- B; 1°AP-C)
 - a.3) 2nd drive circuit of shunt opening release control (2° AP-ABC)
 - a.4) 3rd drive circuit of under-voltage release control (3° AP-ABC)
- b) three-pole CBs
 - b.1) drive circuit of shunt closing release control (CH-ABC)
 - b.2) 1st drive circuit of shunt opening release control (1° AP-ABC)
 - b.3) 3rd drive circuit of under-voltage release control (3° AP-ABC)

7.2.4.3 Signalizations

It shall be reported in the terminal board the contacts referred to the following signalizations:

- a) single-pole CBs
 - a.1) remote/local selector switch in local (P) position (43SP-Prova)
 - a.2) intervention of motor protection device and/or auxiliary supply missing (42RT)
 - a.3) anti-condensation circuit anomaly (AnR152)
 - a.4) motor maximum operation time (BX)
 - a.5) discharged springs (P4 MOLLE)
 - a.6) 1st minimum gas density level (P1 GAS)
 - a.7) 2nd minimum gas density level (P4 GAS)
 - a.8) open position (caX152)
 - a.9) close position (ccX152)
 - a.10) poles discrepancy (DP)
 - a.11) incongruence of drive circuit of under-voltage release control (3°AP-INC)
 - a.12) locking of drive circuit of under-voltage release control (BL3°AP-ABC)
 - a.13) open position (n° 3 152 NC)
 - a.14) close position (n° 3 152 NA)
- b) three-pole CBs
 - b.1) remote/local selector switch in local (P) position (43SP-Prova)
 - b.2) intervention of motor protection device and/or auxiliary supply missing (42RT)
 - b.3) anti-condensation circuit anomaly (AnR152)
 - b.4) motor maximum operation time (BX)
 - b.5) discharged springs (P4 MOLLE)
 - b.6) 1st minimum gas density level (P1 GAS)
 - b.7) 2nd minimum gas density level (P4 GAS)
 - b.8) open position (caX152)
 - b.9) close position (ccX152)
 - b.10) locking of drive circuit of under-voltage release control (BL3°AP-ABC)

	GLOBAL STANDARD	Page 23 of 57
	HV CIRCUIT-BREAKERS	GSH001 Rev. 02 03/08/2017

b.11) open position (n° 3 152 NC)

b.12) close position (n° 3 152 NA)

7.2.4.4 *Specific requirements for 245 kV CBs*

In case of single-pole CBs, the 2nd drive circuit of shunt opening release shall work in single-pole way and shall be, including everything is connected to it, galvanically separated respect to all other control and signalization circuits.

About the two 2nd minimum gas density level contacts, the 2nd circuit contact shall operate by mean of a suitable separator relay also on the terminal board signalizations of the 1st circuit, as well as on the closing block.

8 TESTING

8.1 General information

IEC 62271-100 applies.

The tests to be performed on CBs are divided in:

- Type tests;
- Routine tests;
- Commissioning tests.

8.2 Type tests

8.2.1 Visual inspection

The CB, complete of all accessories and fully assembled in operation layout, shall be subject to a visual inspection in order to verify its functional, dimensional and constructive compliance with this Global Standard.

8.2.2 Dielectric tests

(IEC 62271-100 par. 6.2)

8.2.3 Radio interference voltage (r.i.v.) tests

(IEC 62271-100 par. 6.3)

Not applicable for 72,5 kV CBs.

8.2.4 Measurement of the resistance of the main circuit

(IEC 62271-100 par. 6.4)

It shall be measured the contact resistance between each HV terminal and the correspondent CB plate: the measured value shall be $\leq 10 \mu\Omega$.

8.2.5 Temperature-rise tests

(IEC 62271-100 par. 6.5)

The temperature rise test shall be performed excluding the HV terminals.

8.2.6 Short-time withstand current and peak withstand current tests

(IEC 62271-100 par. 6.6)

8.2.7 Verification of the degree of protection

(IEC 62271-100 par. 6.7)

8.2.8 Tightness tests

(IEC 62271-100 par. 6.8)

	GLOBAL STANDARD	Page 24 of 57
	HV CIRCUIT-BREAKERS	GSH001 Rev. 02 03/08/2017

Only in case of gas CBs (SF6 or non-fluorinated greenhouse gases).

The test must be done using test Qm, method 1 “Cumulative Test”, IEC 60068-2-17.

The initial gas concentration C_0 , with CB filled at rated pressure, shall be measured after at least 2 hours from pressurizing; the final concentration C_1 must be measured after more than 8 hours.

8.2.9 Electromagnetic compatibility (EMC) tests

(IEC 62271-100 par. 6.9)

8.2.10 Additional tests on auxiliary and control circuits

(IEC 62271-100 par. 6.10)

For this verification the manufacturer shall provide a paper copy of the CB electric schemes.

The correct operation of all controls, interlocking, automatic openings and signalizations shall be also verified.

The absorption curves of closing and opening (shunt and under-voltage) releases, taking note of the maximum values (inrush excluded), shall be registered in the following situations:

- at rated voltage;
- at 110% of the rated voltage;
- at 70% of the rated voltage, for opening releases;
- at 85% of the rated voltage, for closing release.

The absorption curves of the motors, taking note of the maximum values (inrush excluded) and of the springs charging times, shall be registered in the following situations:

- at rated voltage;
- at 110% of the rated voltage;
- at 85% of the rated voltage.

8.2.11 Mechanical and environmental tests

(IEC 62271-100 par. 6.101)

Humidity test is not required.

A new definition for operation with under-voltage release is added, similar to “opening time”, IEC 62271-100 par. 3.7.133 a):

“The opening time with under-voltage release is the time interval between the instant when the voltage drops suddenly to zero, the circuit breaker being in closed position, and the instant when the arcing contact are separated in all poles.”

In case of the under-voltage release is requested, its characteristics shall be verified in accordance with IEC 62271-1 (par. 5.8.4) at ambient temperature.

Moreover, for routine tests and commissioning tests purpose, the reference values and their tolerance at 110%, 100% and 70% of the rated voltage shall be provided.

8.2.12 Short-circuit current making and breaking tests

(IEC 62271-100 par. 6.102 to 6.106)

8.2.13 Critical current tests

(IEC 62271-100 par. 6.107)

If applicable (see 6.107.1)

8.2.14 Single-phase and double-earth fault tests

(IEC 62271-100 par. 6.108)

	GLOBAL STANDARD	Page 25 of 57
	HV CIRCUIT-BREAKERS	GSH001 Rev. 02 03/08/2017

8.2.15 Short-line fault tests

(IEC 62271-100 par. 6.109)

8.2.16 Out-of-phase making and breaking tests

(IEC 62271-100 par. 6.110)

8.2.17 Capacitive current switching tests

(IEC 62271-100 par. 6.111)

8.2.18 X-radiation test procedure for vacuum interrupters

(IEC 62271-1 par. 6.11)

Only in case of vacuum CBs.

8.2.19 Seismic qualification

If requested, CBs (including the support) shall be compliant with seismic qualification, according with standards listed in 4.2.3.

8.2.20 Protective treatments

Hot dip galvanized coatings on iron and steel components shall be verified in accordance with ISO 1461 by mean of magnetic flux equipments, performing at least 5 measures on each component, in uniform manner on the various surfaces, avoiding edges and angular parts.

The verification of other protective coatings shall be performed considering their characteristics: the manufacturer will indicate the minimum thickness allowed and the others characteristics.

8.2.21 Tests on insulators

The ceramic insulators shall be tested in accordance with IEC 62155.

The composite insulators shall be tested in accordance with IEC 61462.

8.2.22 Specific type tests

8.2.22.1 *Enel Distribuzione*

8.2.22.1.a) *Tests to verify the encloses endurance to gas internal pressure*

Only in case of gas CBs.

On the number and typologies of encloses provided by D.M. 1/12/1980 and subsequent modifications, it shall be performed the required tests to obtain ISPESEL certification for the verification of encloses endurance to gas internal pressure.

8.3 Routine tests

The Routine tests (also called acceptance tests) shall be made in the manufacturer's factory on each apparatus supplied, to ensure the product compliance with the sample approved during the conformity assessment (homologation, certification etc.) process and on which the type tests have been performed.

Test values/results shall be in compliance with rated values (and relative tolerances).

The manufacturer shall provide, for each CB supplied, the report of all measures and tests carried out.

8.3.1 Dielectric test on the main circuit

(IEC 62271-100 par. 7.1)

8.3.2 Tests on auxiliary and control circuits

(IEC 62271-100 par. 7.2)

	GLOBAL STANDARD	Page 26 of 57
	HV CIRCUIT-BREAKERS	GSH001 Rev. 02 03/08/2017

Functional tests (par. 7.2.2 of IEC 62271-1) shall be done only at rated voltage. About density meters, the verification shall be performed at ambient temperature, in the real operating position, using nitrogen and no SF₆, with decreasing pressure values. The density meters verification can be also performed using SF₆, if precautions are taken to prevent SF₆ dispersion in the environment.

Dielectric tests (par. 7.2.4 of IEC 62271-1) shall be done applying 1 kV for 1 s.

Electronic devices, motors etc. can be excluded by dielectric test only if agreed during the conformity assessment (homologation, certification etc.) process.

8.3.3 Measurement of the resistance of the main circuit

(IEC 62271-100 par. 7.3)

It shall be performed after mechanical operating tests.

The ambient temperature influence can be neglected.

The test can be performed without HV terminals, specifying it in the test report.

8.3.4 Tightness test

(IEC 62271-100 par. 7.4)

It shall be performed at least at 2nd minimum gas density level (block).

8.3.5 Design and visual checks

(IEC 62271-100 par. 7.5)

The checks shall be performed referring to conformity assessment (homologation, certification etc.) documents and verifying damage absence.

8.3.6 Mechanical operating tests

(IEC 62271-100 par. 7.101)

It shall be recorded:

- a. at V_{max}, V_n, V_{min}, closing (C) and opening (O) times, time spread (on each release);
 - a1. at V_{max}, V_n, V_{min}, opening (O) times, time spread of under-voltage release (if present – see 8.2.11) and it shall be verified its compliance with IEC 62271-1 par. 5.8.4;
- b. at V_n, close-open (CO) time and open-close-open (O – t - CO) cycle;
- c. at V_n, the operation time of one of each type (make and break) of auxiliary contacts, respect to the operation of main contacts on closing and on opening of CB;
- d. no-load travel curves.

The spring recharging time of the motor after a closing operation and its absorption (maximum value, inrush excluded) shall be measured only at V_n.

8.3.7 Protective treatments

The thickness of the protective coatings shall be verified according with 8.2.20.

8.3.8 Specific routine tests

8.3.8.1 *Enel Distribuzione*

8.3.8.1.a) *Tests to verify the encloses endurance to gas internal pressure*

Only in case of gas CBs.

Manufacturer shall provide the “*Certificazione di rispondenza*” (see D.M. 1/12/1980).

8.4 Commissioning tests

(IEC 62271-100 par. 10.2)

The Commissioning tests (also called on-site acceptance tests) shall be performed in the Enel Group Distribution Company plant on each apparatus supplied, after its installation.

	GLOBAL STANDARD	Page 27 of 57
	HV CIRCUIT-BREAKERS	GSH001 Rev. 02 03/08/2017

The manufacturer, at the end of the on-site tests, will deliver the report containing the results of measures and tests performed on the CB.

This report, in paper and in electronic format (e.g. one or more “pdf” files) shall include also factory routine tests.

8.4.1 Visual inspection, general checks and functionality test of the auxiliary and control circuits

The correct assembling (performed in accordance with manufacturer’s drawings and instructions), the damages absence and the presence of all accessories and of the required documentation shall be verified.

Functionality tests of the auxiliary and control circuits shall be performed after dielectric tests. About density meters, the verification shall be performed with the same modalities of the routine test (see 8.3.2), paying attention to the ambient conditions (solar radiation, temperature) and, in case of three density meters, comparing between them the intervention threshold pressure measured values.

8.4.2 Mechanical Operating Tests

Before mechanical operating tests 10 C-O cycles on each release shall be performed.

It shall be recorded:

- a. at V_{max} , V_n , V_{min} , closing (C) and opening (O) times, time spread (on each release);
 - a1. at V_{max} , V_n , V_{min} , opening (O) times, time spread of under-voltage release (if present – see 8.2.11) and it shall be verified its compliance with IEC 62271-1 par. 5.8.4;
- b. at V_n , close-open (CO) time and open-close-open (O – t - CO) cycle;
- c. at V_n , the operation time of one of each type (make and break) of auxiliary contacts, respect to the operation of main contacts on closing and on opening of CB.

The spring recharging time of the motor after a closing operation and its absorption (maximum value, inrush excluded) shall be measured only at V_n .

8.4.3 Dielectric tests to the auxiliary and control circuits

Dielectric tests (par. 7.2.4 of IEC 62271-1) shall be performed applying 1 kV for 1 s.

Electronic devices, motors etc. can be excluded by dielectric test only if agreed during the conformity assessment (homologation, certification etc.) process.

8.4.4 Measurement of resistance to the main circuit

It shall be performed after mechanical operating tests.

The ambient temperature influence can be neglected.

The test have to be performed with HV terminals on CB plate.

It shall also be measured the contact resistance between each HV terminal and the correspondent CB plate: the measured value shall be $\leq 10 \mu\Omega$.

8.4.5 Tightness test

Only in case of gas CBs (SF6 or non-fluorinated greenhouse gases).

It shall be performed at rated pressure.

The test have to be done using test Qm, method 2 “Probing Test”, IEC 60068-2-17, after all the other tests, eight hours after the gas filling (for example one night is enough).

Fittings, gas density control devices and piping shall be checked (HV insulators have been checked in manufacturer’s factory).

The sensitivity of the sniffing device shall be at least $10^{-8} \text{ Pa} \times \text{m}^3/\text{s}$.

	GLOBAL STANDARD	Page 28 of 57
	HV CIRCUIT-BREAKERS	GSH001 Rev. 02 03/08/2017

9 SUPPLY REQUIREMENTS

9.1 Tender's technical documentation

For each CB typology offered in the tender the supplier shall provide the Annex D properly filled.

9.2 Conformity assessment

9.2.1 Conformity assessment process

The conformity assessment processes (homologation, certification etc.) are specified in the proper contractual documents.

9.2.2 Conformity assessment documentation

The project documentation that the supplier uses to manufacture each CB typology can be divided in Type A documents (public, not confidential) and Type B document (confidential).

For each Enel Group Distribution company requesting a specific CB typology, the manufacturer shall provide a specific documentation set according with the specific requirements stated in this document.

The Type A documentation shall consist at least in:

- 1) type A documents list;
- 2) type B documents list;
- 3) Annex D properly filled;
- 4) overall dimensions drawing, including the stresses transmitted to the foundations;
- 5) insulators drawings and characteristics;
- 6) electric diagram (see 7.2.1-c), low voltage components list included);
- 7) Control Box and Operating Device Box(es) layout drawings;
- 8) overall CB, Control Box and Operating Device Box(es) (with open/closed doors) pictures;
- 9) nameplate and labels drawings (Control Box and Operating Device Box(es), poles, coils etc.);
- 10) CBs installation, use and maintenance handbook/manual;
- 11) routine and commissioning tests:
 - a) test report form (two documents, one for factory tests and one for on-site tests);
 - b) reference values table (with tolerances);

Note: specific detailed instructions to verify the no-load travel curves during maintenance activity shall be included in CB's manual;
 - c) protective coatings (typology, minimum thickness, reference standards);
- 12) documentation of safety device for protection against pole excessive pressure (ISO 4126, only if present);
- 13) list of documentation, materials and accessories supplied;
- 14) only for gas CBs:
 - a) gas circuit(s) drawing;
 - b) gas density control device characteristics and drawings;
 - c) pressure/temperature table for rated density level, 1st minimum gas density level and 2nd minimum gas density level;
- 15) main sub-components suppliers list;
- 16) only for Enel Distribuzione, INAIL (ex ISPESL) Certification "Certificato di conformità del prototipo" - D.M. 01/12/1980;
- 17) only for Enel Distribuzione, Manufacturing and Control Plan (PFC).

	GLOBAL STANDARD	Page 29 of 57
	HV CIRCUIT-BREAKERS	GSH001 Rev. 02 03/08/2017

18) Only for Endesa Distribución: List of components in the Control Box and data sheet of each one

9.3 Packaging, transport, storage and installation/testing

Par. 10.1 and 10.2 of IEC 62271-100 applies.

CB's package shall be suitable to guarantee:

- the protection during transport (including by ship, if necessary);
- an elevation from the ground at least of 100 mm;
- the external storage for at least three months.

On external side of packaging, the following information shall be present:

- 1) manufacturer name;
- 2) manufacturing year/month;
- 3) manufacturer designation type;
- 4) manufacturer serial number;
- 5) Enel component codification (see Annex A; i.e.: GSH001/1 - XXXXX);
- 6) contract number;
- 7) destination substation;
- 8) total weight;
- 9) lifting information (showing the points and the correct method of lifting);
- 10) only for Enel Distribuzione, the bar code, in accordance with PVR006.

With each CB the following items shall be supplied (items from 3 to 8 on paper):

- 1) the support structure (only if requested, including any interface plates if necessary) and the anchor bolts to the civil works (stainless or hot dip galvanized steel, chemical or expansion type);
- 2) springs hand-crank (and other tools according to the manufacturer design);
- 3) list of documentation, materials and accessories supplied;
- 4) overall dimensions drawing;
- 5) electric diagram;
- 6) CB installation, use and maintenance handbook/manual;
- 7) routine and commissioning tests:
 - a) routine (factory) test reports;
 - b) reference values table (with tolerances);
- 8) only for gas CBs:
 - a) dielectric gas;
 - b) pressure/temperature table for rated density level, 1st minimum gas density level and 2nd minimum gas density level;
- 9) one CD-Rom containing the whole type A documentation (pdf file format).

Waste (including packaging and the gas cylinders) shall be disposed by Manufacturer.

	GLOBAL STANDARD	Page 30 of 57
	HV CIRCUIT-BREAKERS	GSH001 Rev. 02 03/08/2017

ANNEX A – LOCAL COMPONENTS CODIFICATION

Type code	Edesur	Ampla	Coelce	Chilectra	Codensa	Enel Distribuz.	Edelnor	Enel Distributie	Endesa D.E.
GSH001/1		4544579	6771180				6783145		6710641
GSH001/2							6792645		
GSH001/3						150126		150126	6710642
GSH001/4		6777842			6781265	150127		150127	6710643
GSH001/5	0103-2500								6710644
GSH001/6									
GSH001/7						150186			
GSH001/8						150187			
GSH001/9						150196			
GSH001/10					6801822	150197	6797232		
GSH001/11	0103-0303								
GSH001/12									

ANNEX B – DIMENSIONAL DRAWINGS

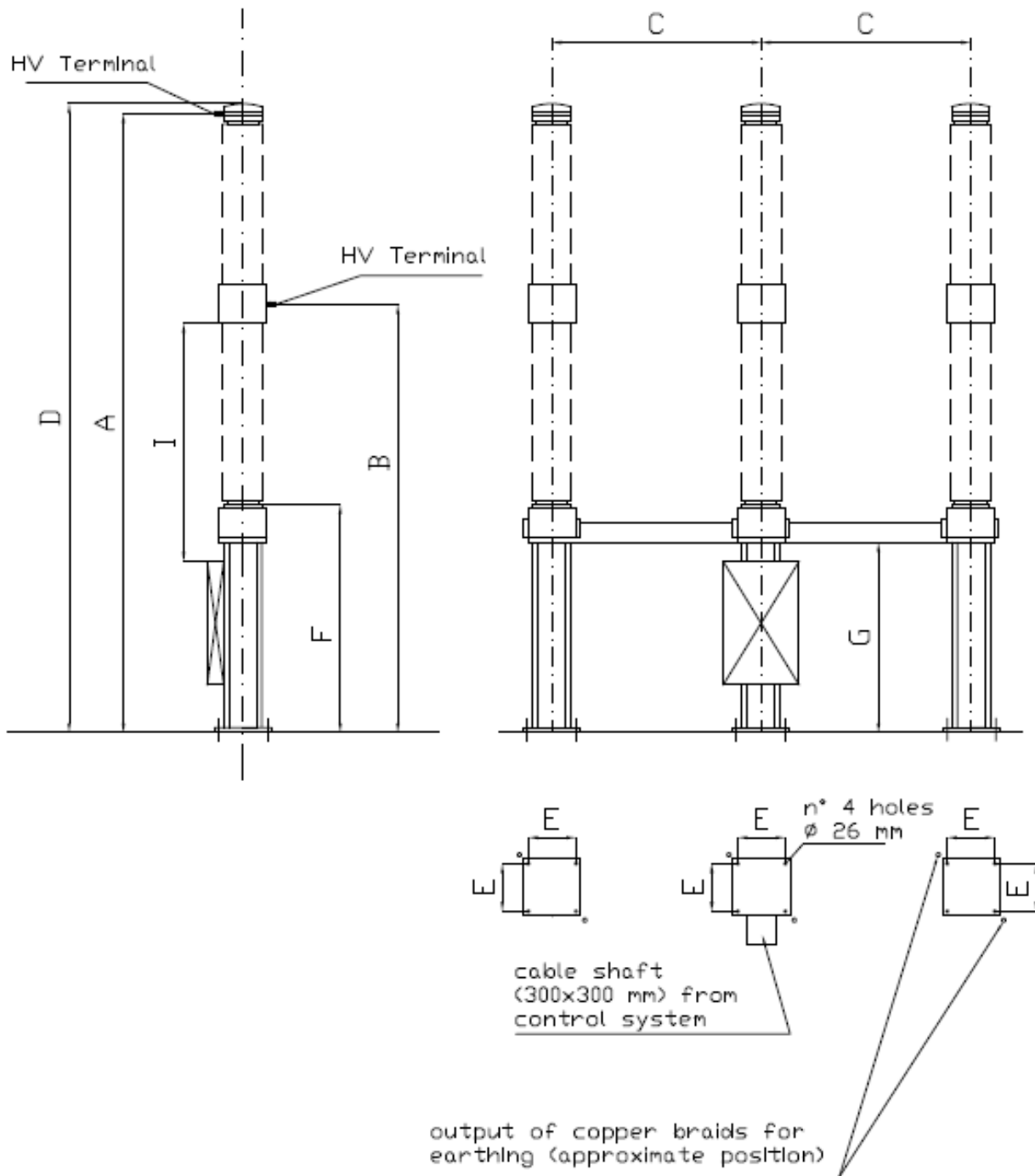

Figure 1

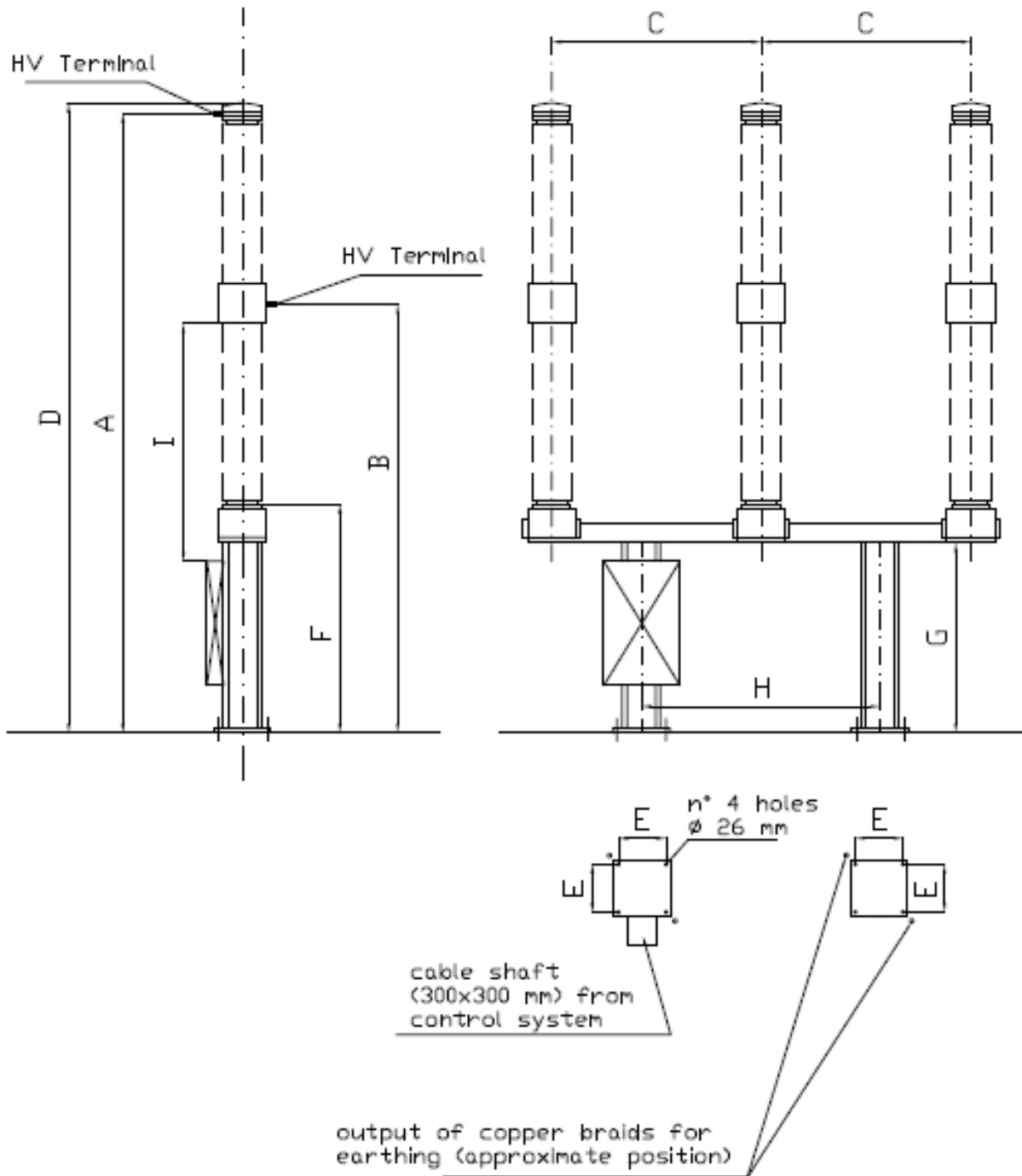



Figure 2

	GLOBAL STANDARD	Page 33 of 57
	HV CIRCUIT-BREAKERS	GSH001 Rev. 02 03/08/2017

Company	Ref. figure	A	B	C	D	E	F	G	H	I
Ampla	2	-	≥ 3100	≥ 790	≤ 4300	-	≥2250 ⁶	≥1700	-	-
Coelce	2	-	≥ 3100	≥ 790	≤ 4300	-	≥2250 ⁶	≥1700	-	-
Edelnor							≥2250 ⁶			
Endesa	2	-	≥ 3130	≥630	-	-	≥2300 ⁷	-		≥1400 ⁷

Table 1 – Dimensions for 72,5 kV CBs (in mm)⁸

Company	Ref. figure	A	B	C	D	E	F	G	H	I
Ampla	2	-	≥3600	≥1630	≤5200	-	≥2250 ⁶	≥2530		-
Chilectra			≥ 3500	≥ 1750	≤ 7000	400	≥2250 ⁶			
Codensa	2	≥ 5180	≥ 3630	≥ 1750	≥ 5480	370 x 230	≥2250 ⁶	2530		
Edesur			≥3700				≥2250 ⁶			
Endesa	2	-	≥ 3800	≥1300	-	-	≥2300 ⁷	-		≥2000 ⁷
Enel Distributie	1	≤6500	4500 ±30	2000	≤6500	500	≥2250 ⁶	≥2000		
Enel Distribuz.	1	≤6500	4500 ±30	2200	≤6500	500	≥2250 ⁶	≥2000		

Table 2 – Dimensions for 145 kV CBs (in mm)⁸

⁶ In accordance with par. 7.2.4 of IEC 61936-1

⁷ In accordance with Real Decreto Riesgo Eléctrico 614/2001 and NNM001.- Normas de operación definiciones. This distance is mandatory unless there is a physical barrier allowing distance I to be shorter.

⁸ Blank cell means that there isn't a mandatory requirement for that characteristic

	GLOBAL STANDARD	Page 34 of 57
	HV CIRCUIT-BREAKERS	GSH001 Rev. 02 03/08/2017

Company	Ref. figure	A	B	C	D	E	F	G	H	I
Enel Distribuz.	1	≤6500	4500 ±30	2200	≤6500	500	≥2250 ⁶	≥2000		

Table 3 – Dimensions for 170 kV CBs (in mm)⁸

Company	Ref. figure	A	B	C	D	E	F	G	H	I
Chilectra	1		≥4600	≥3500	≤8500	400	≥2250 ⁶			
Codensa							≥2250 ⁶			
Edelnor							≥2250 ⁶			
Edesur			≥4600				≥2250 ⁶			
Enel Distribuz.	1	≤8000	5300 ±30	3200		500	≥2250 ⁶	≥2000		

Table 4 – Dimensions for 245 kV CBs (in mm)⁸

ANNEX C – ELECTRICAL SCHEMES
C.1 – ENDESA ELECTRICAL SCHEMES

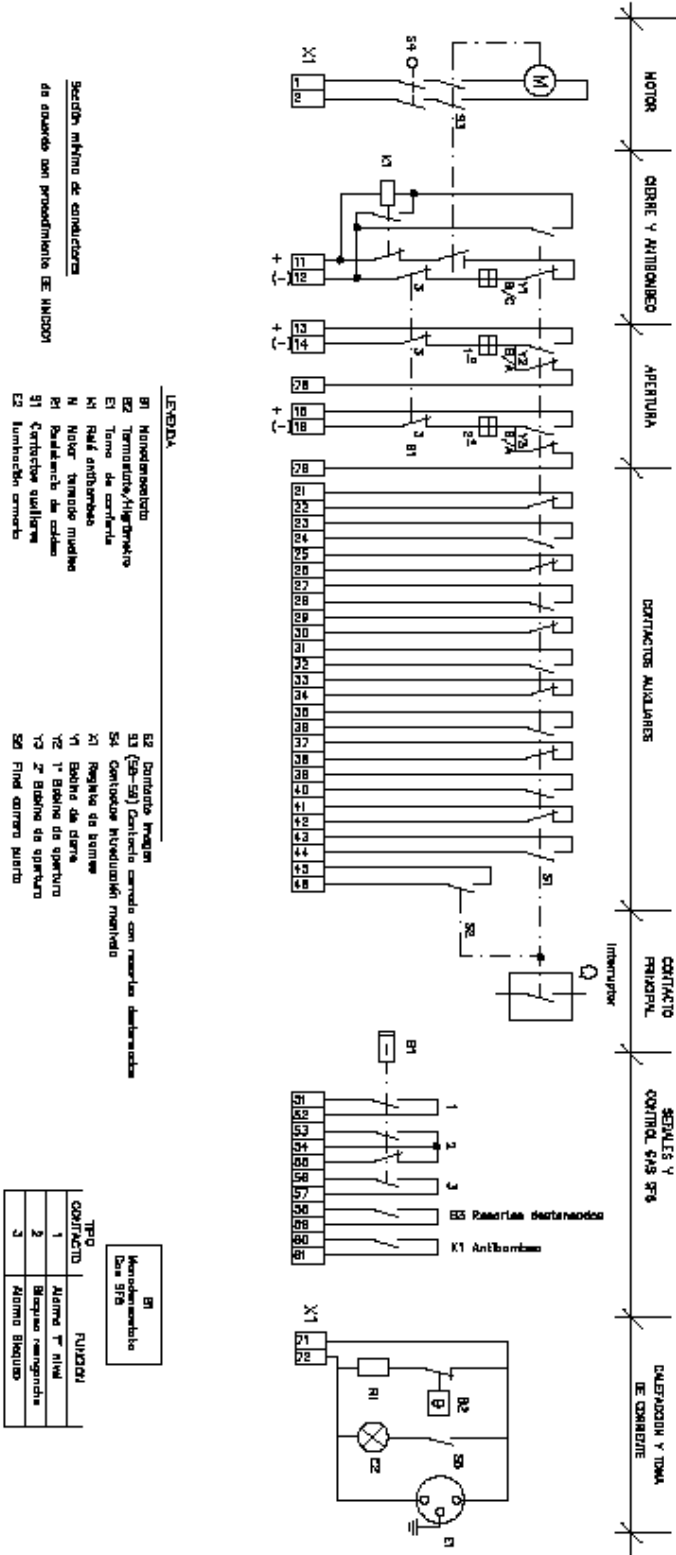

Según mínimo de conductores de acuerdo con procedimiento EE NMD001

- LENDIA**
- B1 Nondeformable
 - B2 Termosensitivo/Hidroelástico
 - E1 Torno de corriente
 - K1 Relé antibombas
 - N Motor "torcido" muelle
 - R1 Resistencia de cables
 - S1 Contacto sueltos
 - E2 Llave de control

- B2 Contacto freque
- S1 (S1-S2) Contacto cerrado con resorte de liberación
- S4 Contacto nivelación mínimo
- X1 Regulador de bombe
- Y1 Bobina de cierre
- Y2 1ª Bobina de apertura
- Y3 2ª Bobina de apertura
- S0 Fin de carrera puerta

TIPO CONTACTO	FUNCIÓN
1	Alarma 1ª nivel
2	Alarma emergencia
3	Alarma bloqueo

C.2 – ENEL DISTRIBUTIE AND ENEL DISTRIBUZIONE ELECTRICAL SCHEMES AND FLOWCHARTS

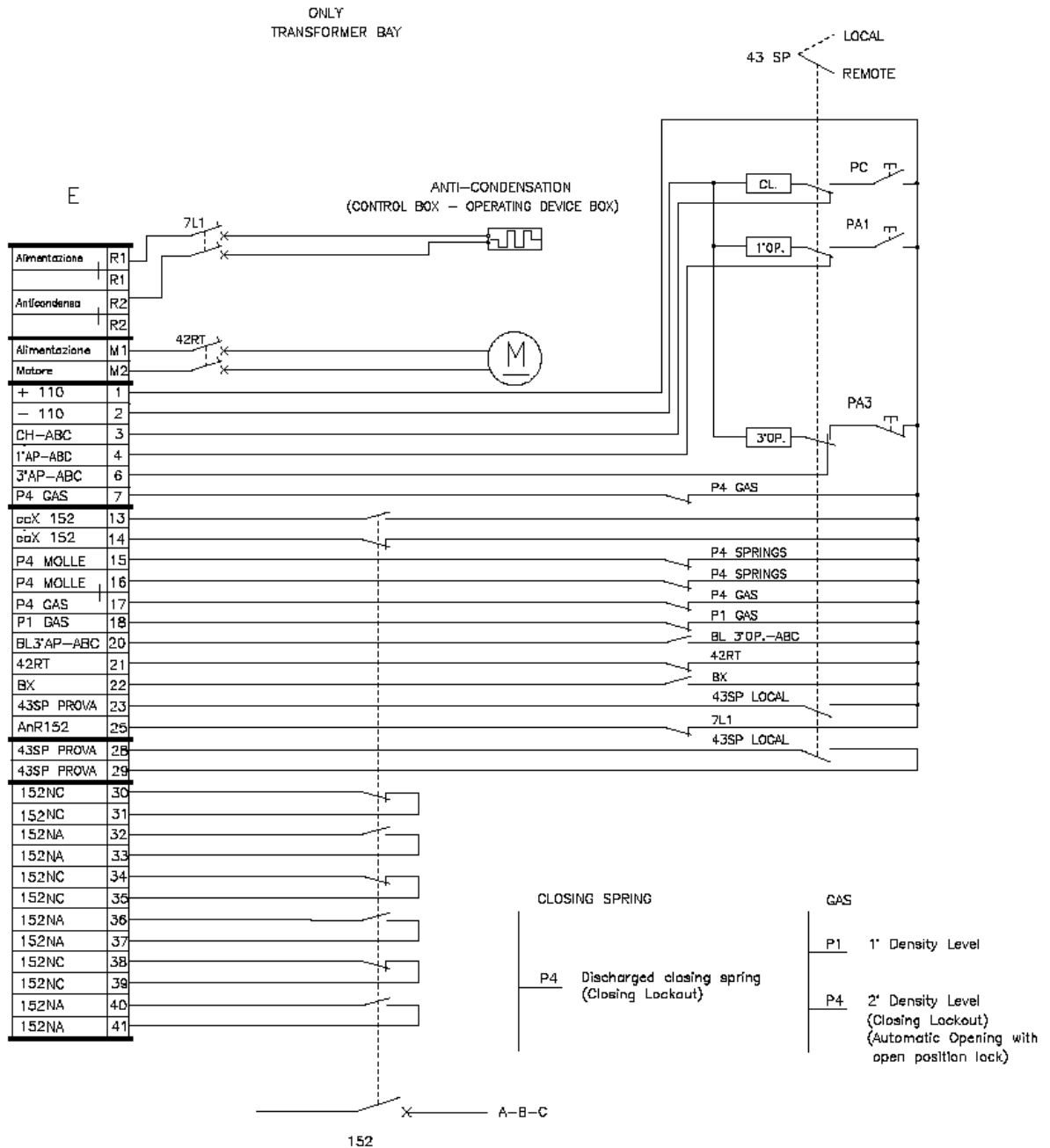

NOTE:

Circuit diagram – Reference conventional conditions: CB in open position, closing spring discharged, gas absence (only for gas insulated CB), 43 SP selector in S position, undervoltage release unlocked, absence of A.C. and D.C. auxiliary supplies.

Figure 3 (three-pole CBs electrical scheme)

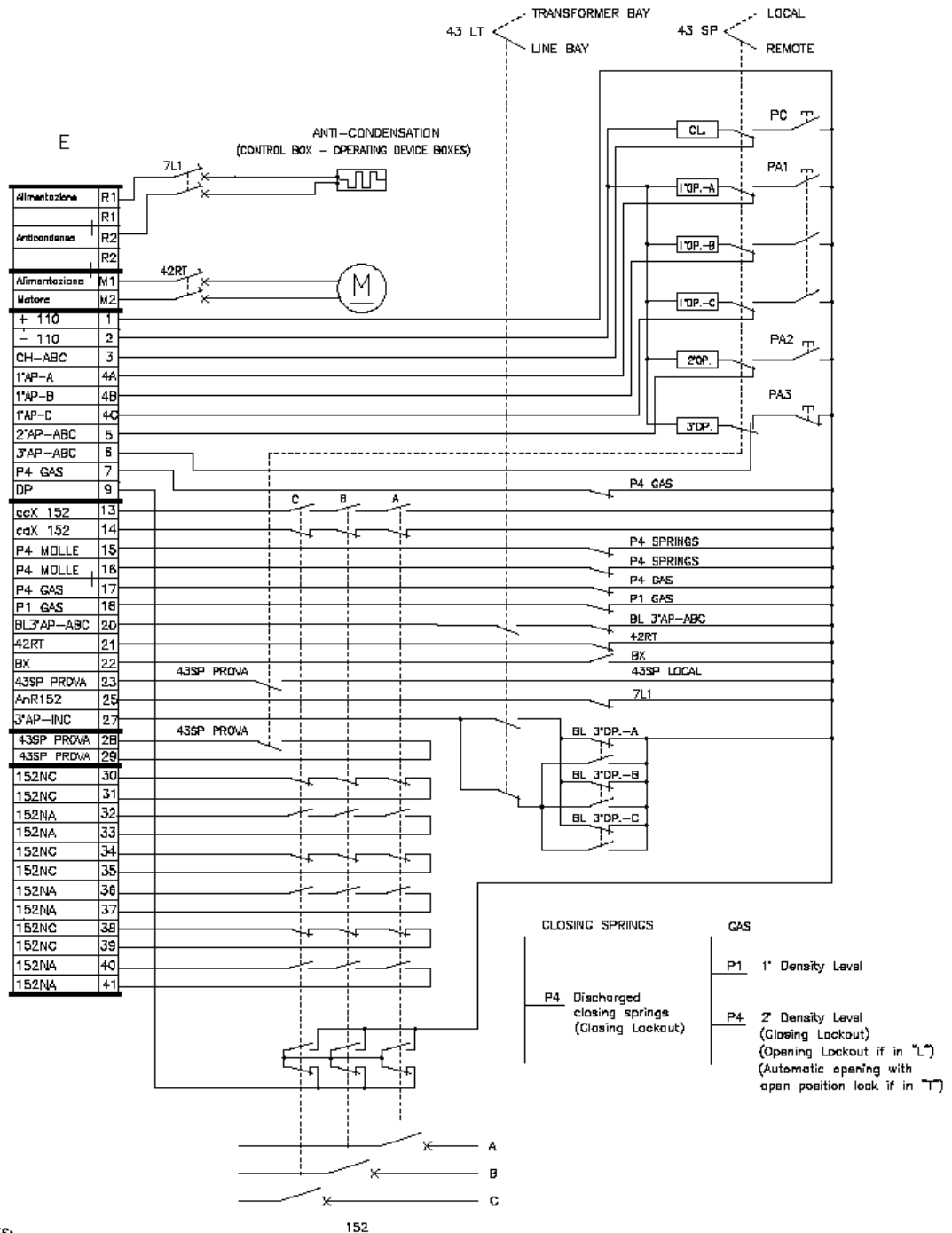

NOTES:

- 1) Circuit diagram - Reference conventional conditions: CB in open position, closing springs discharged, gas absence (only for gas insulated CB), 43 SP selector in S position, 43 LT selector in L position, undervoltage release locked, absence of A.C. and D.C. auxiliary supplies.
- 2) If CB is used in transformer bay, jumper between the gaups of terminal blocks: 4A - 4B - 4C
2D - 21 - 22 - 23.
- 3) Only for gas insulated CB's: Low density gas CB's automatic opening (1st and 2nd release) are ON if 43 LT selector is in T position.

Figure 4 (72,5 ÷ 170 kV single-pole CBs electrical scheme)

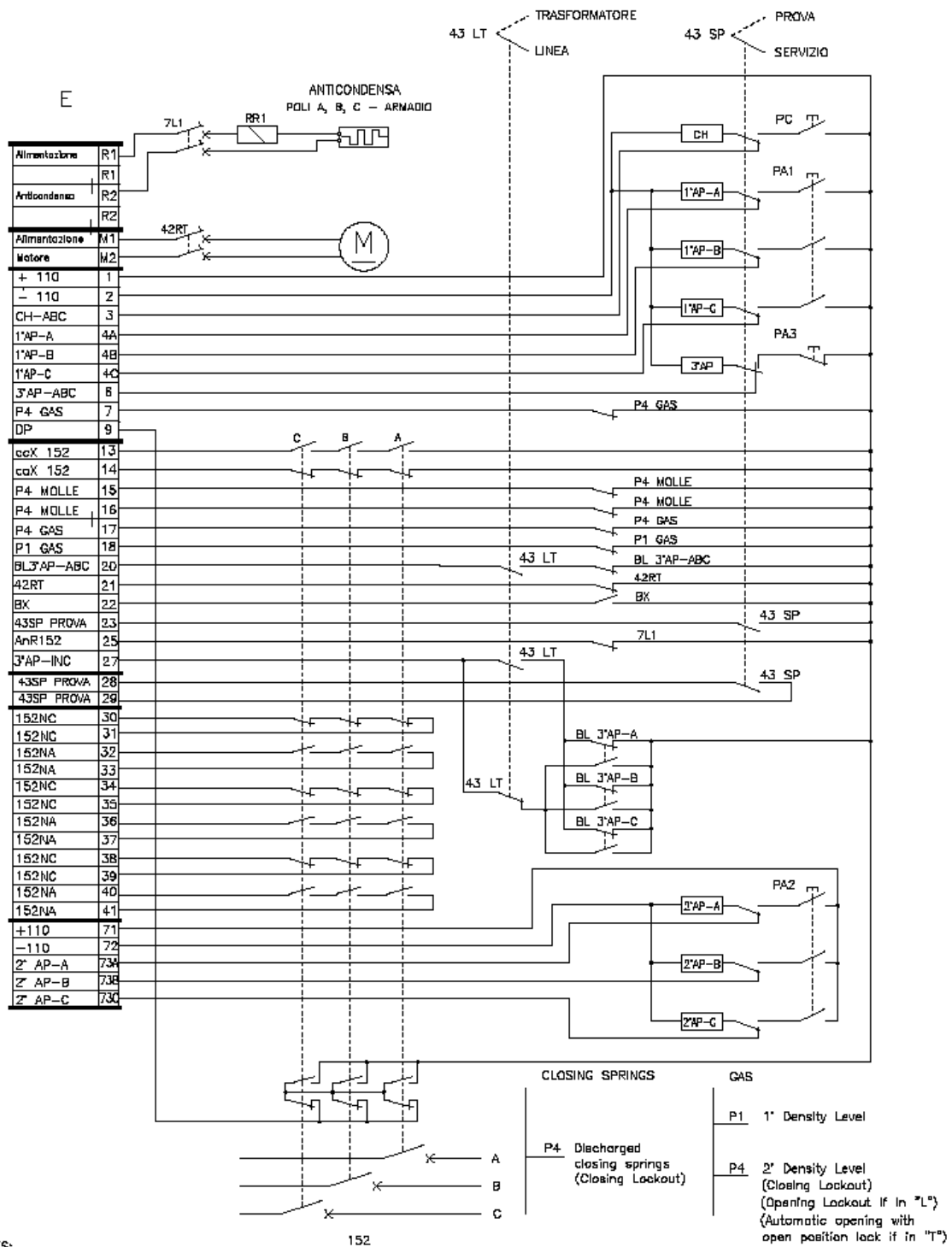
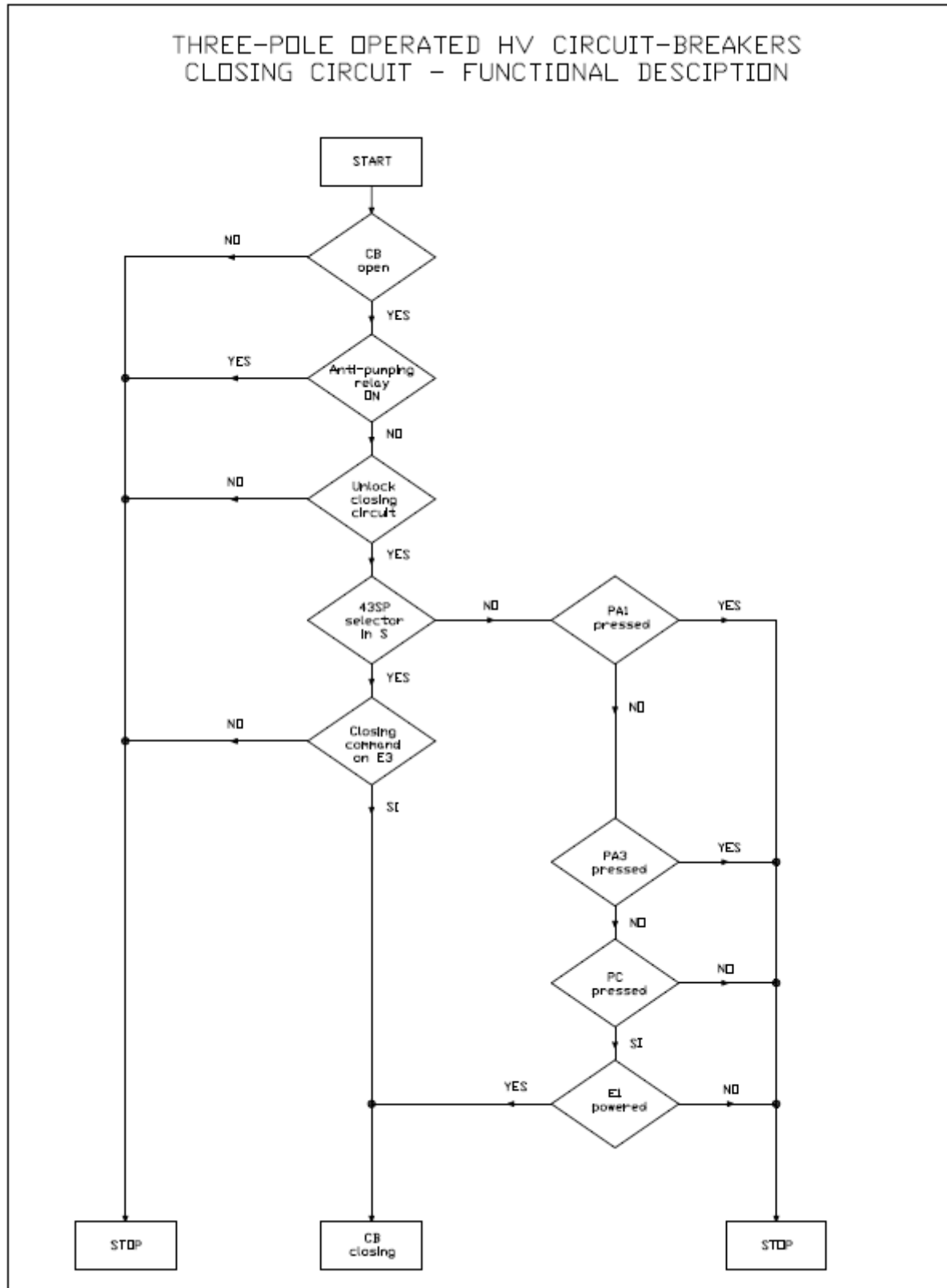
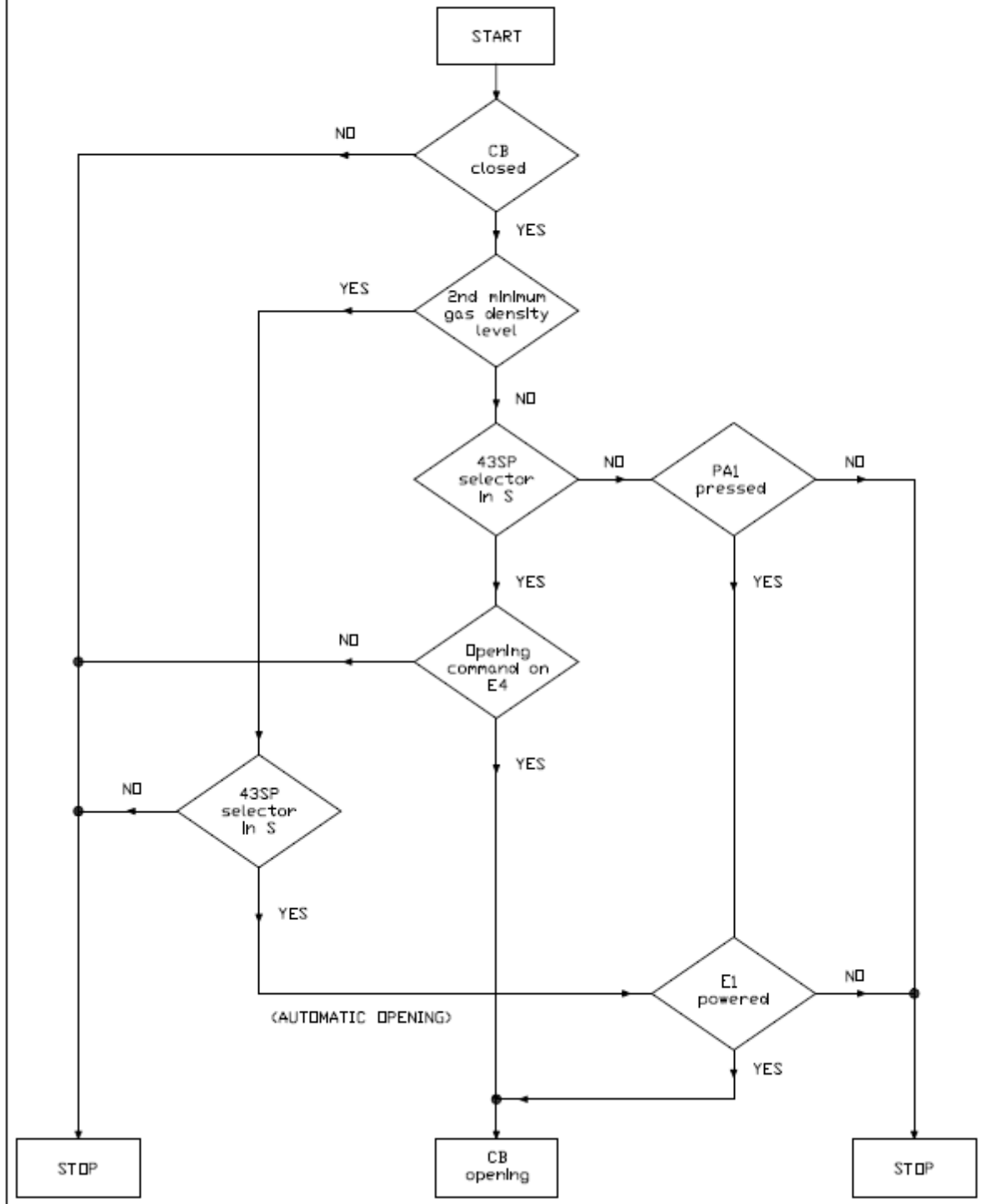

Figure 5 (245 kV single-pole CBs electrical scheme)

THREE-POLE CIRCUIT BREAKERS FLOWCHARTS:



THREE-POLE OPERATED HV CIRCUIT-BREAKERS
1st OPENING CIRCUIT - FUNCTIONAL DESCRIPTION



THREE-POLE OPERATED HV CIRCUIT-BREAKERS
3rd OPENING CIRCUIT - FUNCTIONAL DESCRIPTION
(UNDER-VOLTAGE RELEASE)

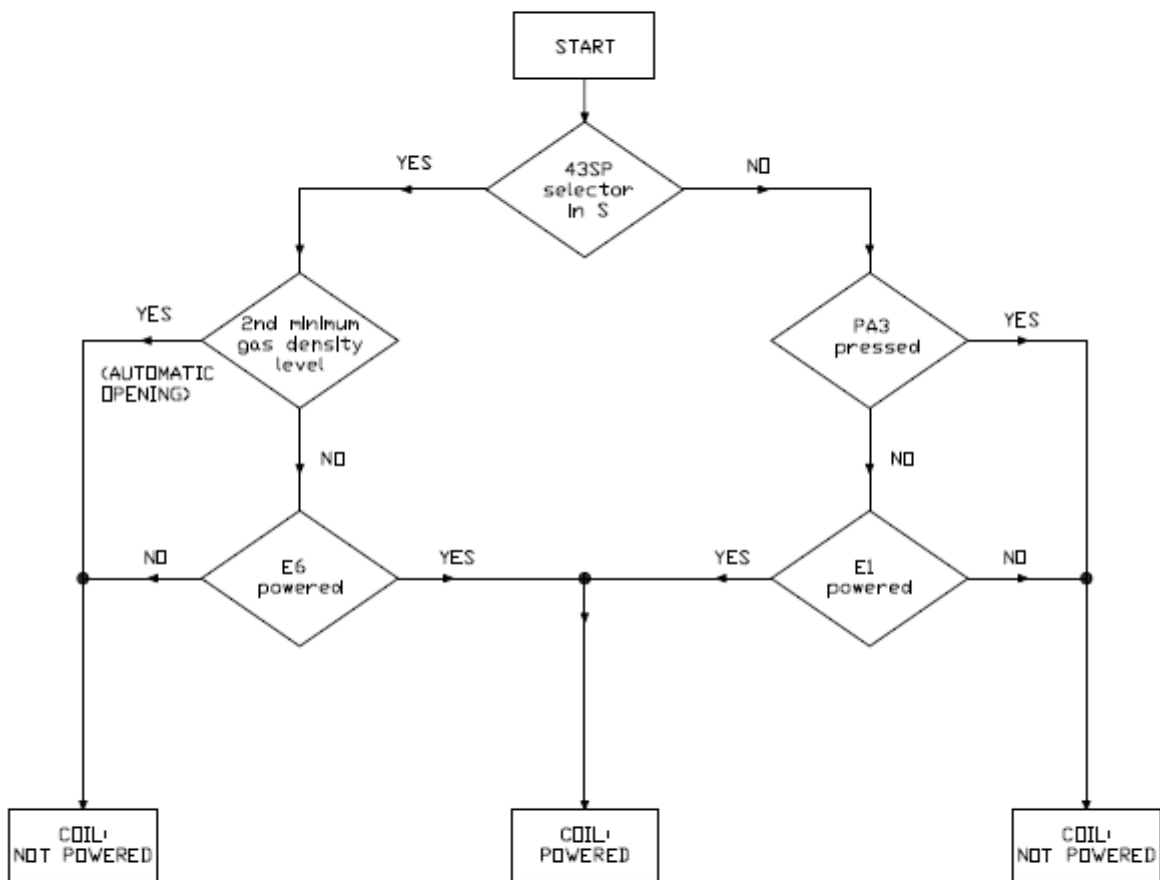

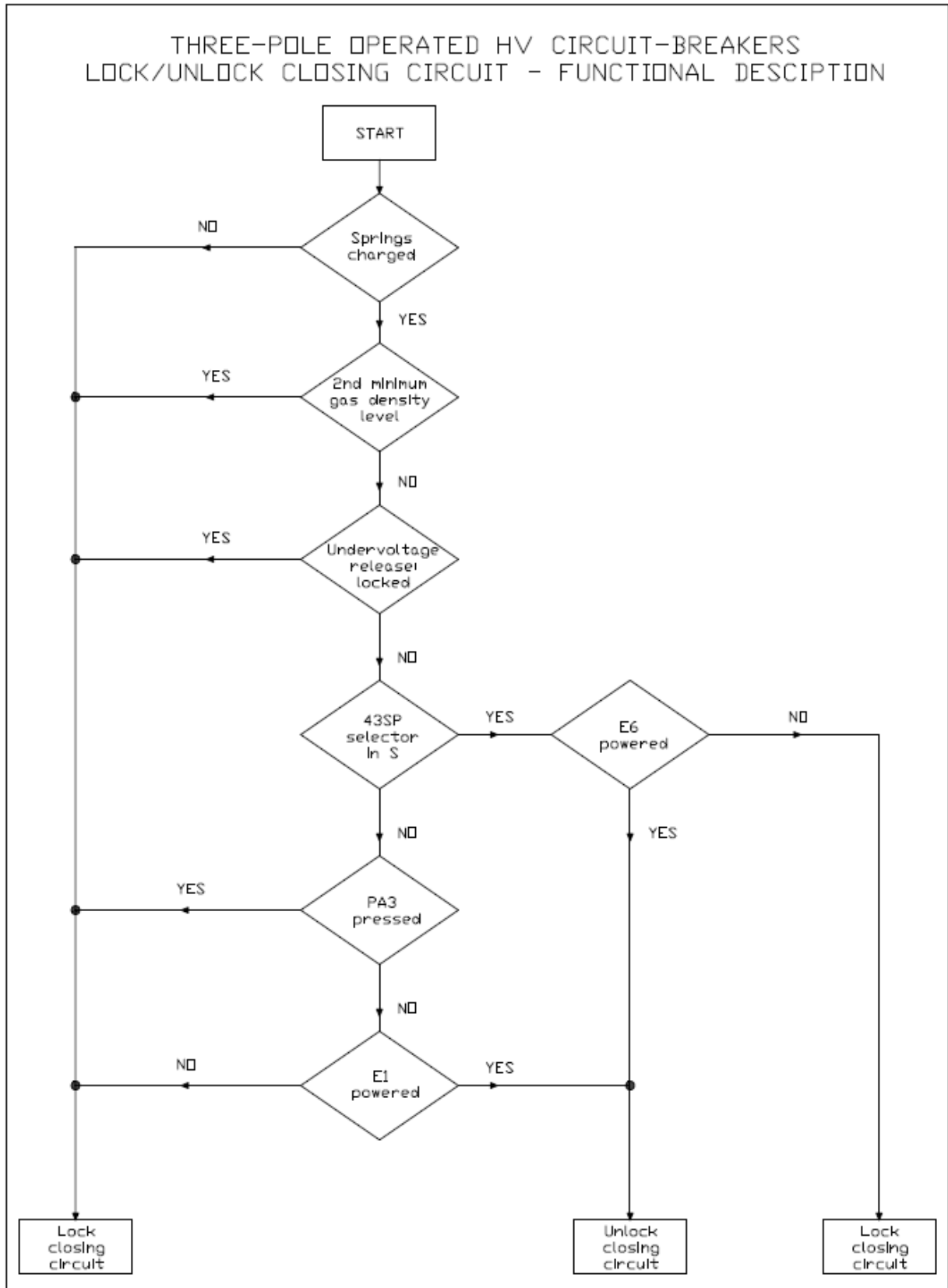

SINGLE-POLE CIRCUIT BREAKERS FLOWCHARTS:

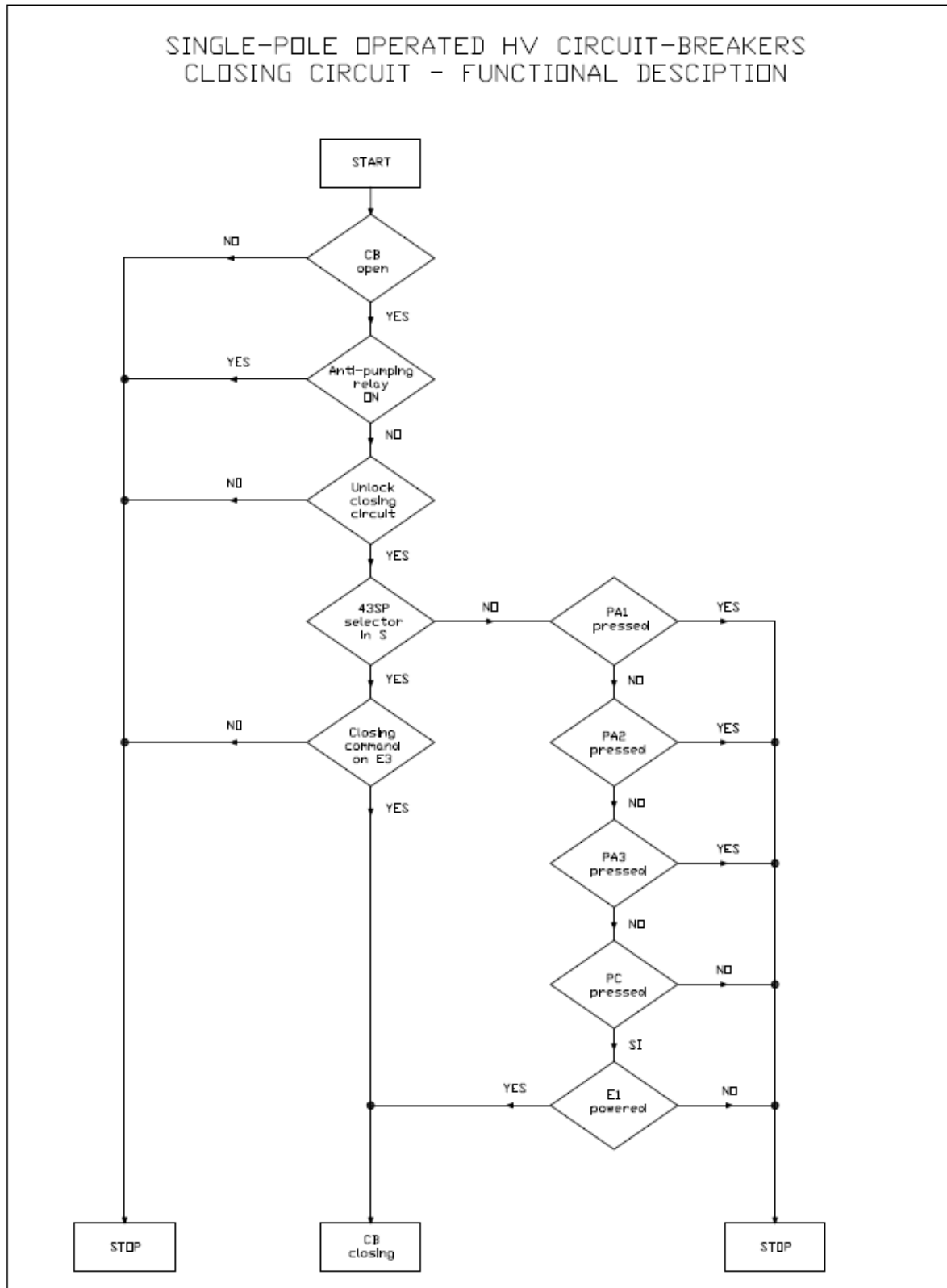

SINGLE-POLE OPERATED HV CIRCUIT-BREAKERS
1st OPENING CIRCUIT - FUNCTIONAL DESCRIPTION

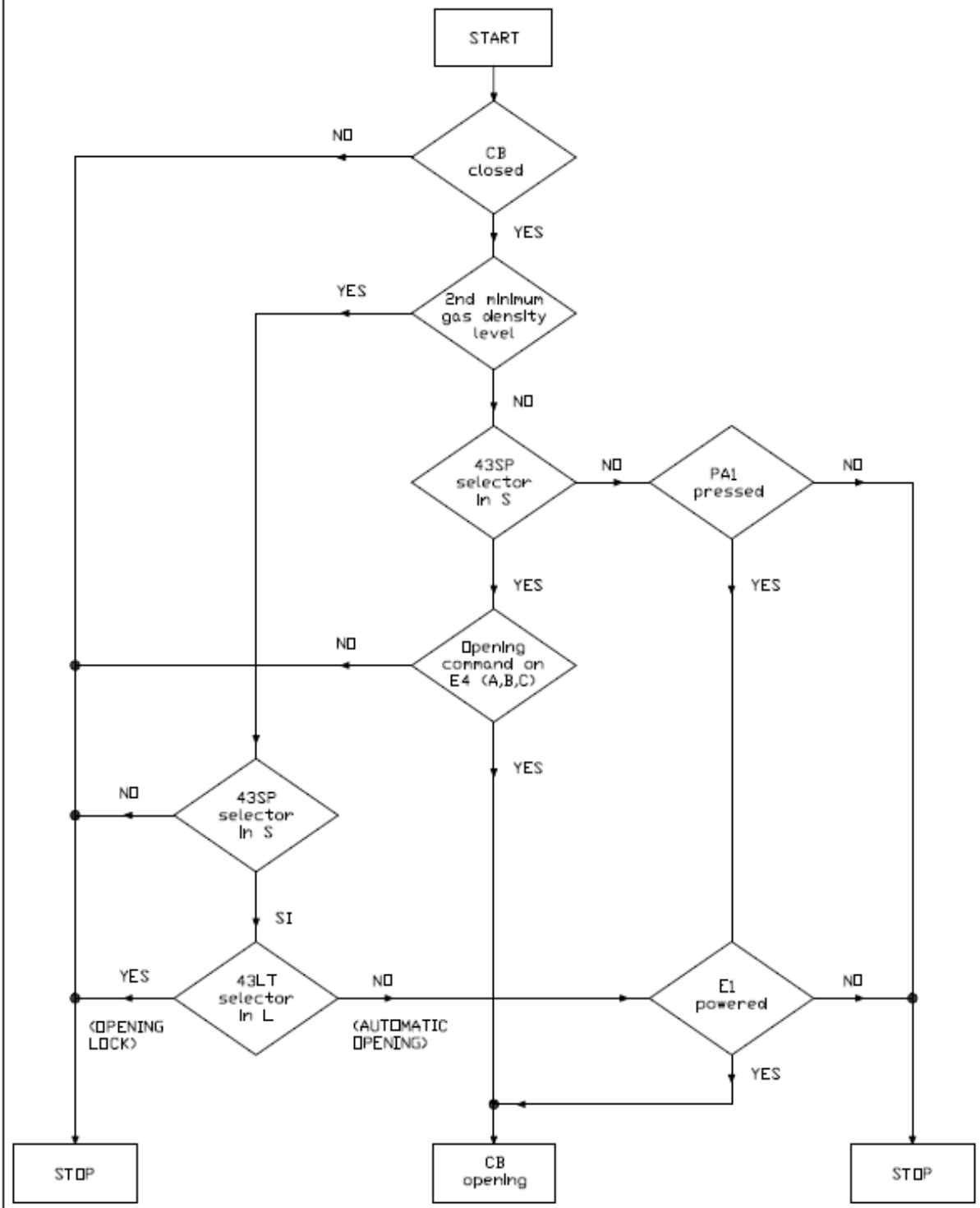

SINGLE-POLE OPERATED HV CIRCUIT-BREAKERS
2nd OPENING CIRCUIT - FUNCTIONAL DESCRIPTION

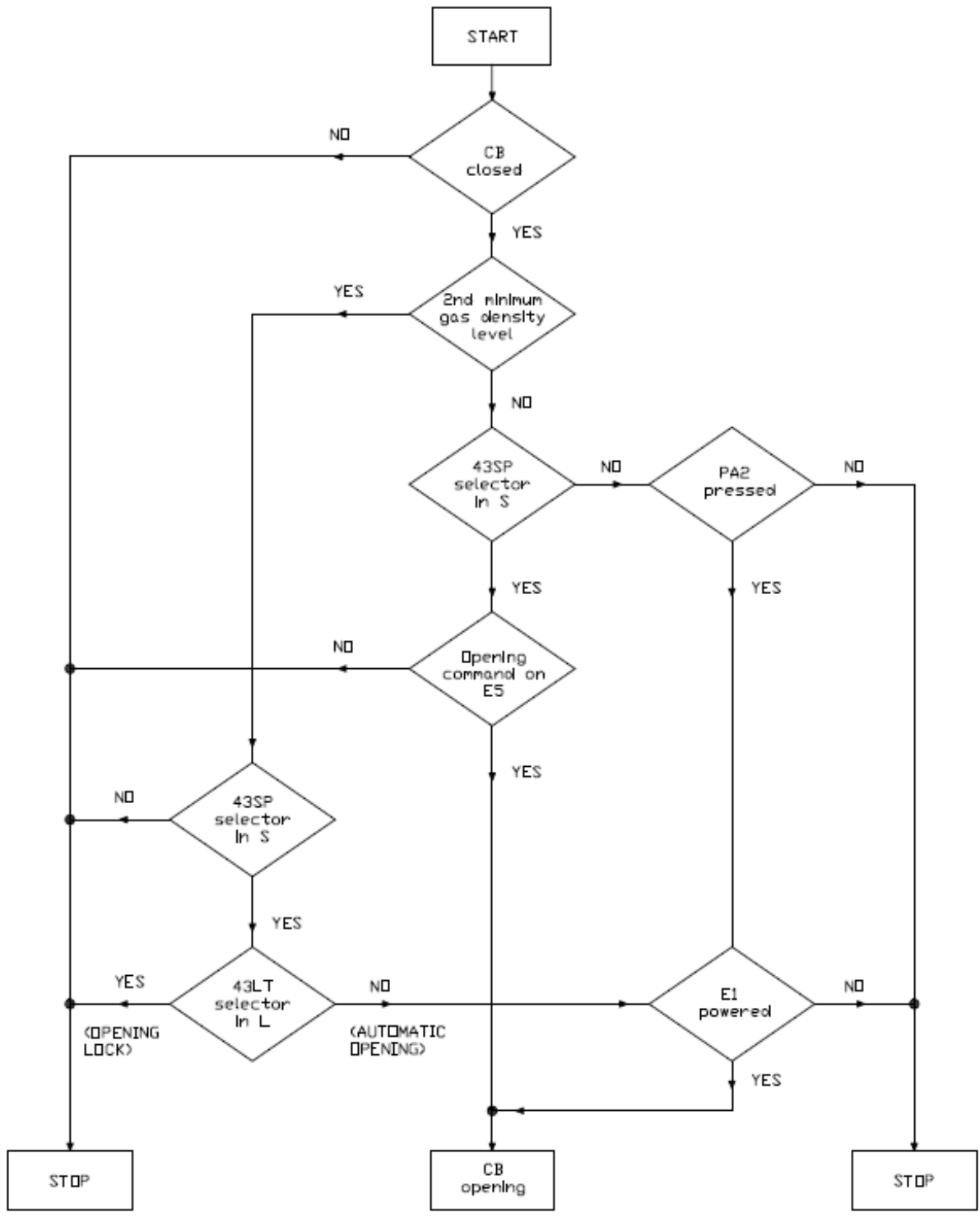

SINGLE-POLE OPERATED HV CIRCUIT-BREAKERS
3rd OPENING CIRCUIT - FUNCTIONAL DESCRIPTION
(UNDER-VOLTAGE RELEASE)

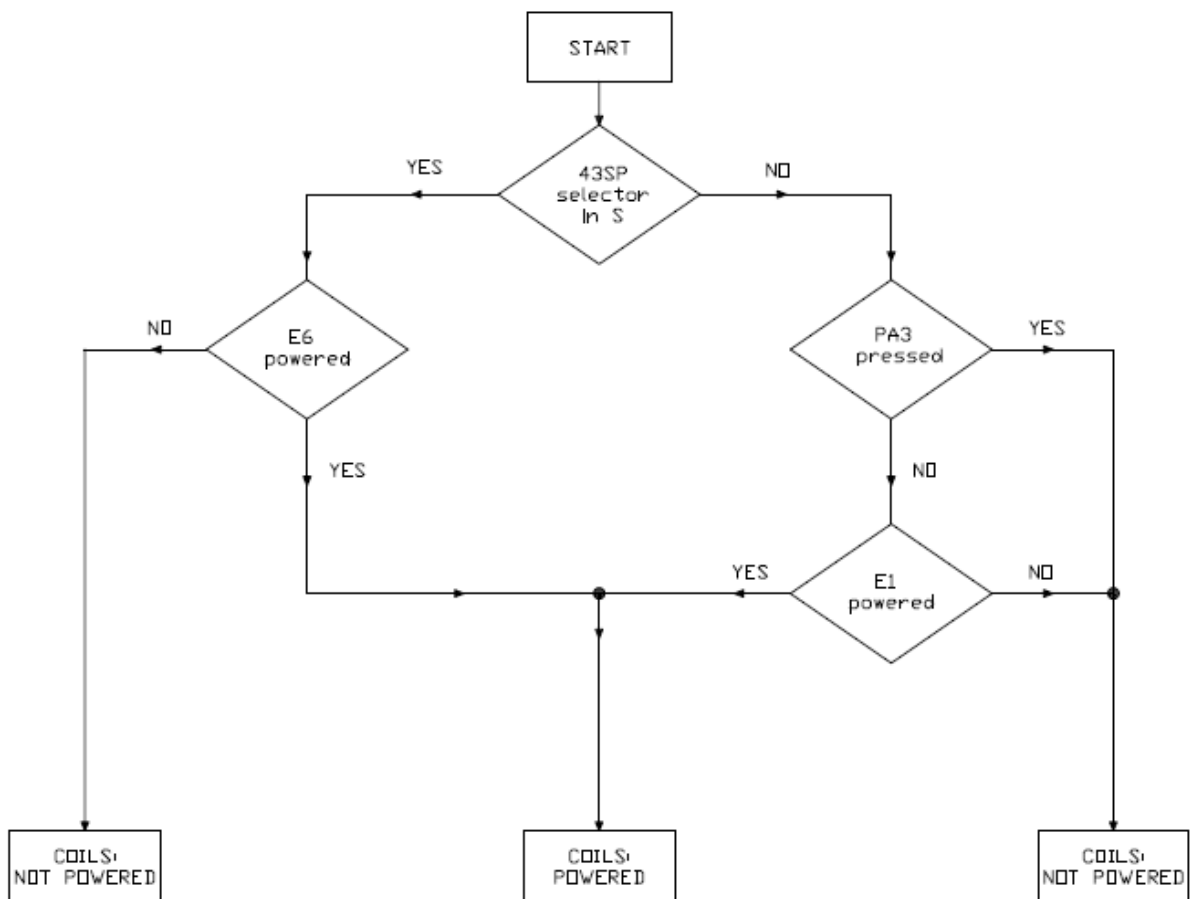

SINGLE-POLE OPERATED HV CIRCUIT-BREAKERS
 LOCK/UNLOCK CLOSING CIRCUIT - FUNCTIONAL DESCRIPTION

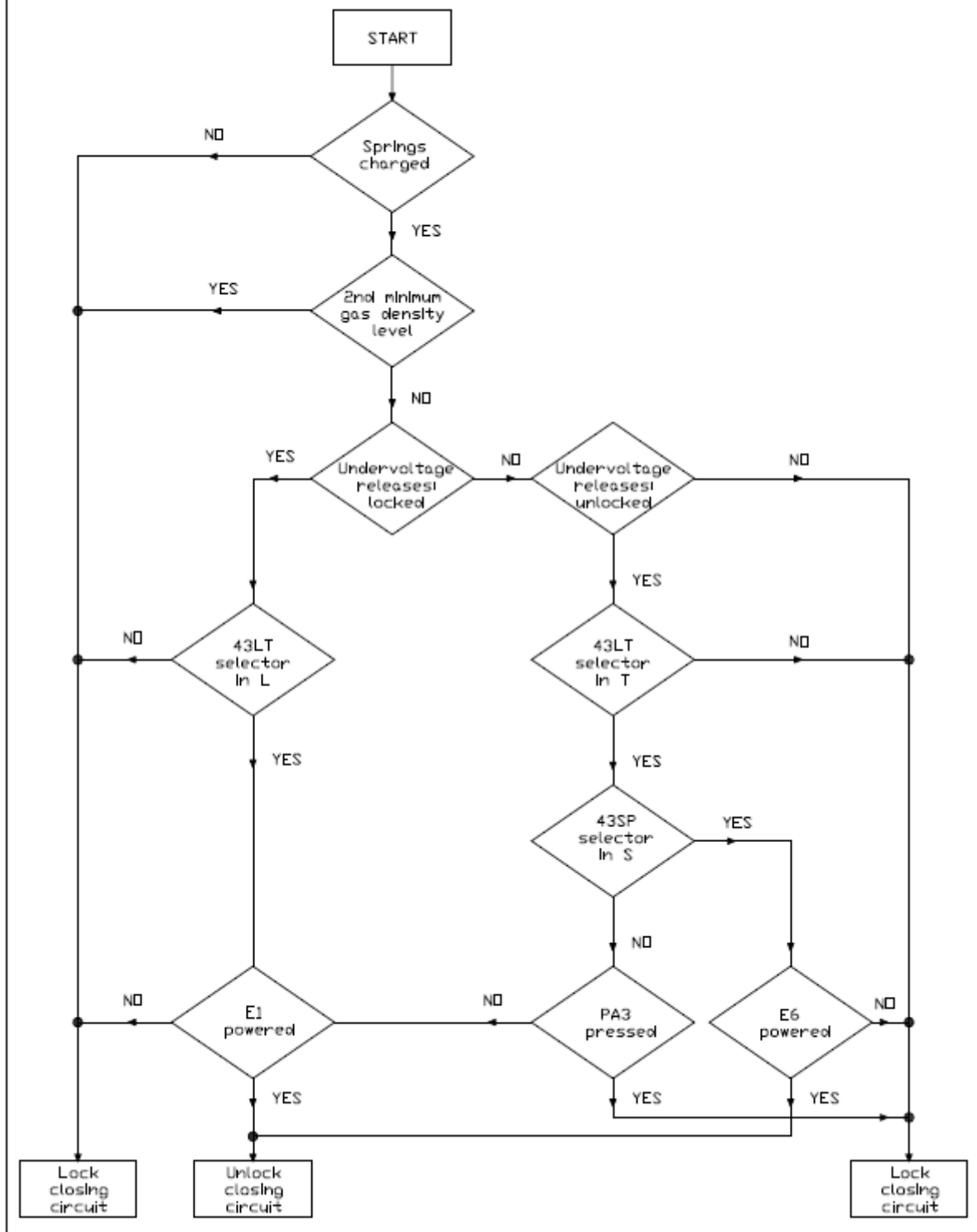

C.3 – LATAM ELECTRICAL SCHEMES

COELCE:

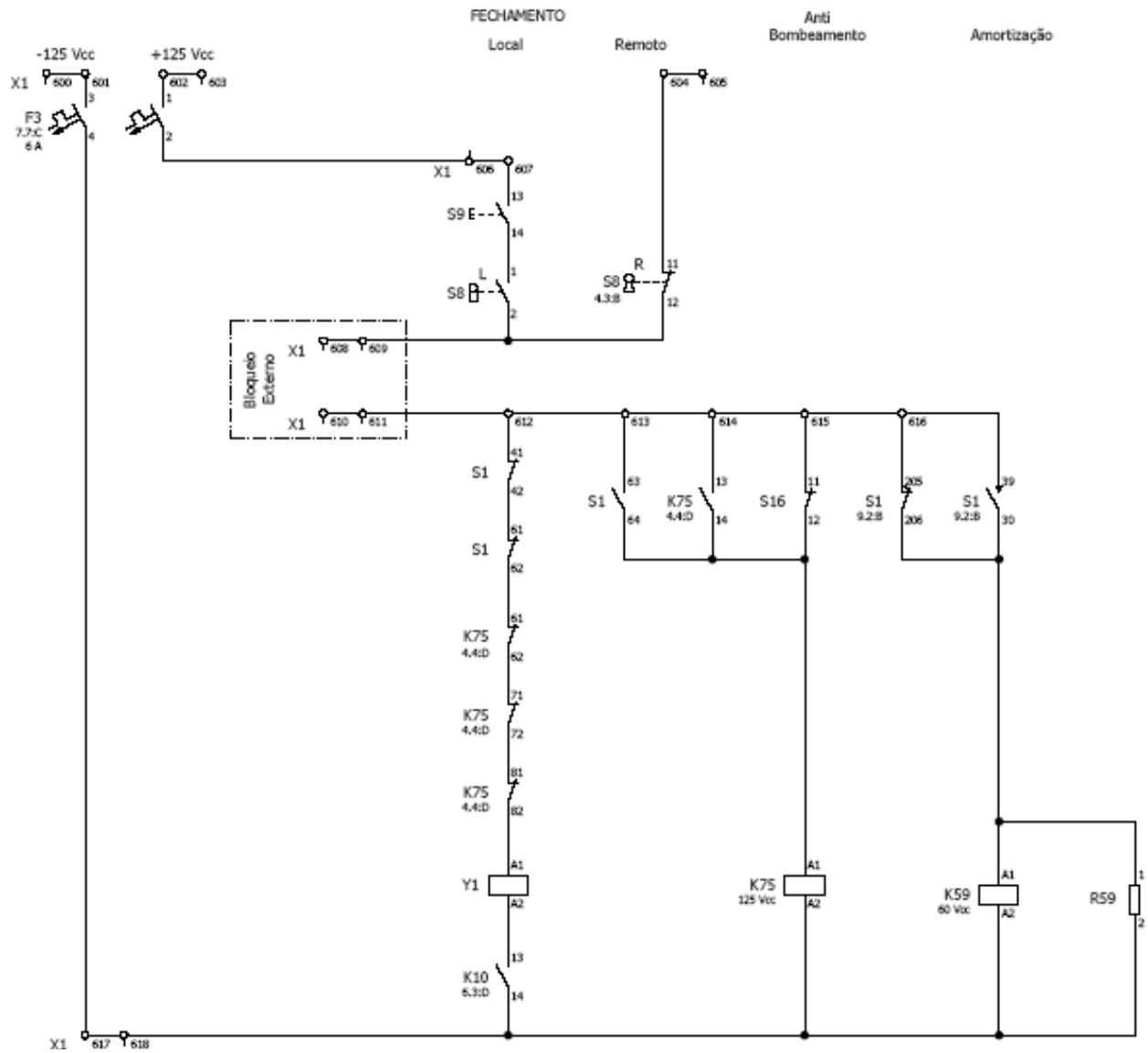

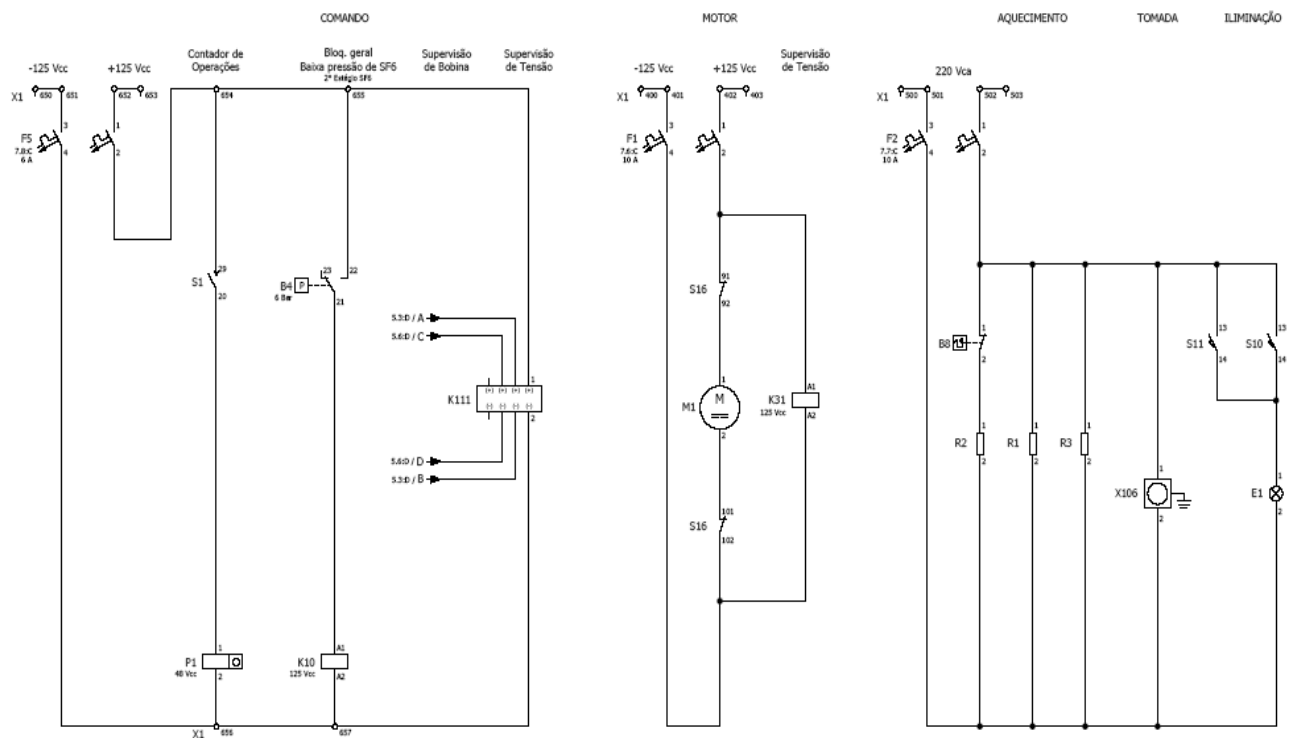
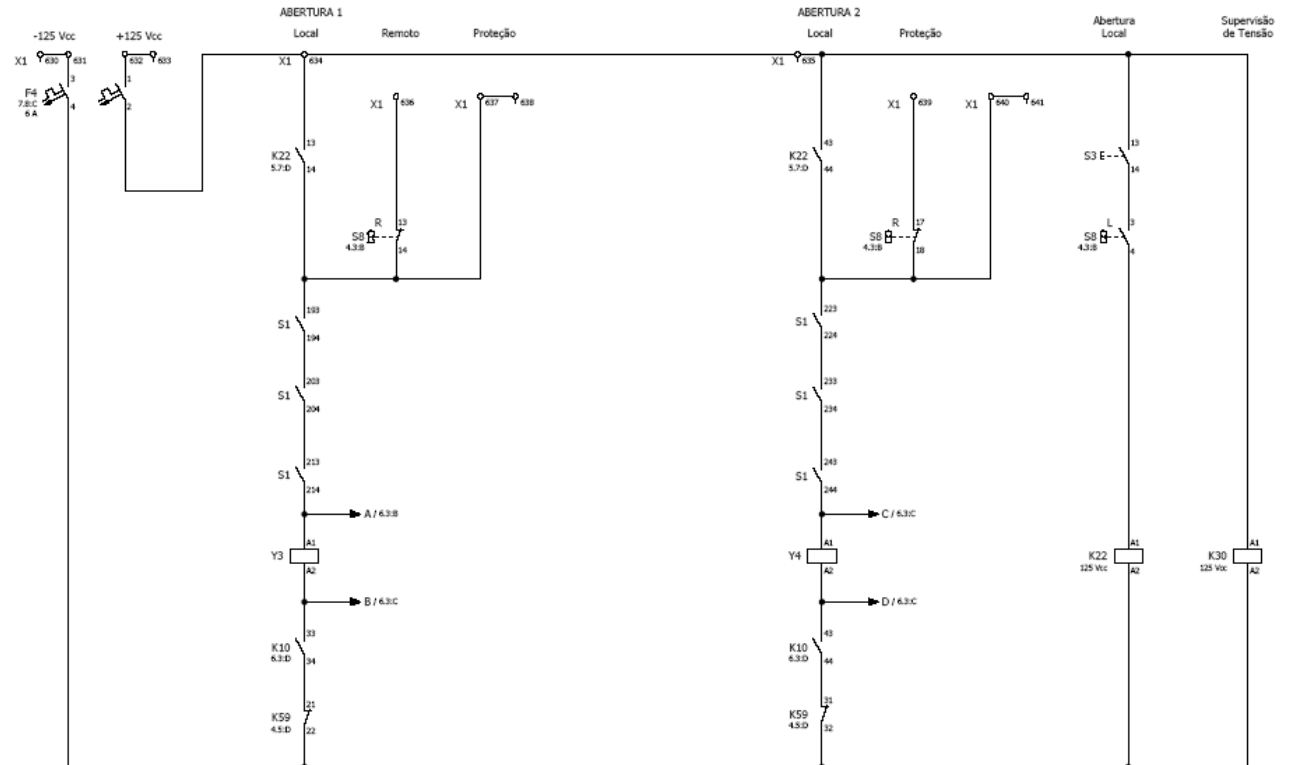

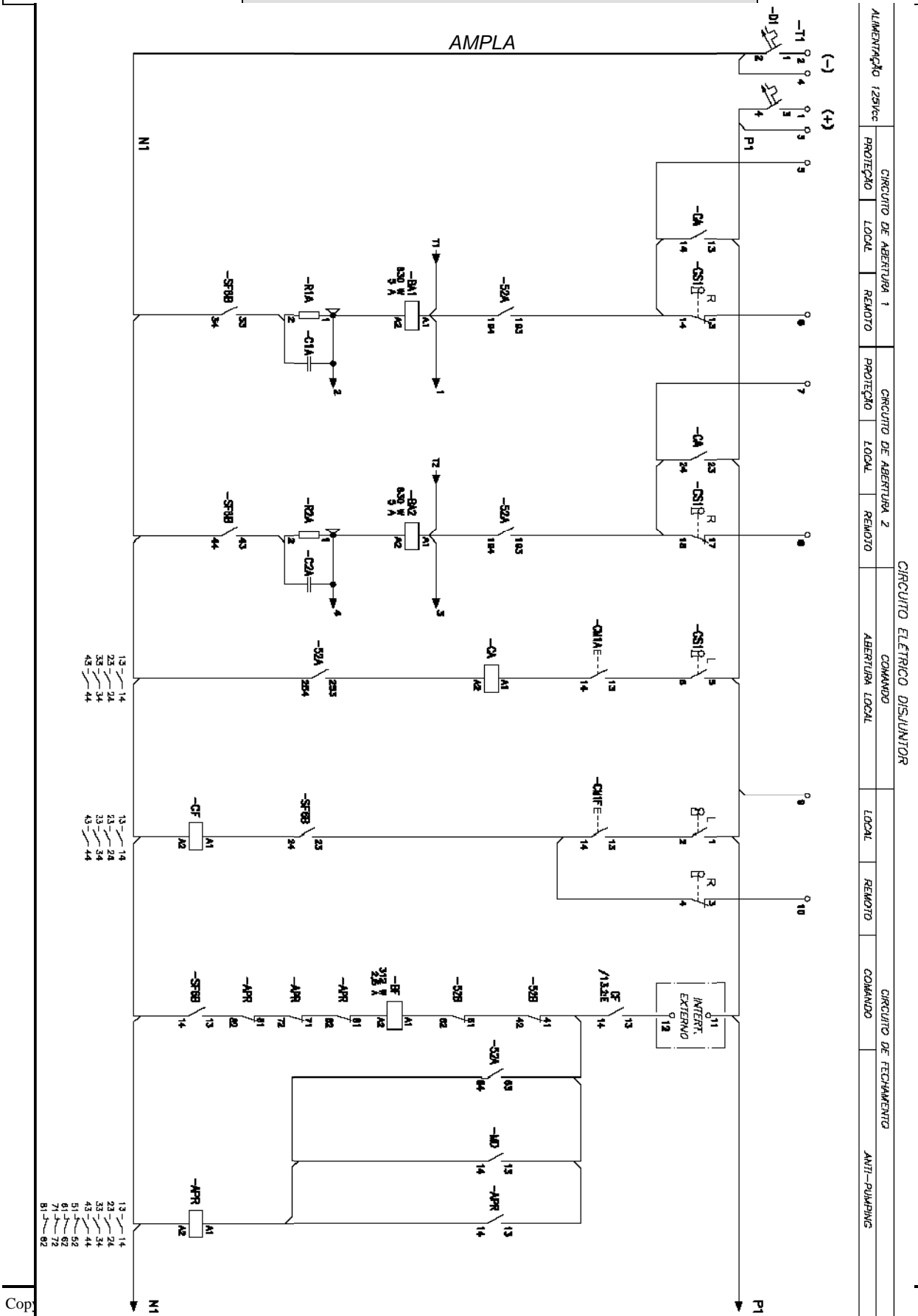



CONTADOR OPERAÇÃO		BLOQUEIO GERAL SFE		FALTA TENSÃO		TRIP BOB. 1		TRIP BOB. 2		TRIP CAPACITIV		SUPERSENSIÇÃO BOBINA	
		2ª ESTAGIO										ABERTURA 1	
												ABERTURA 2	
												FALTA VCC	

CIRCUITO ELÉTRICO DISJUNTOR

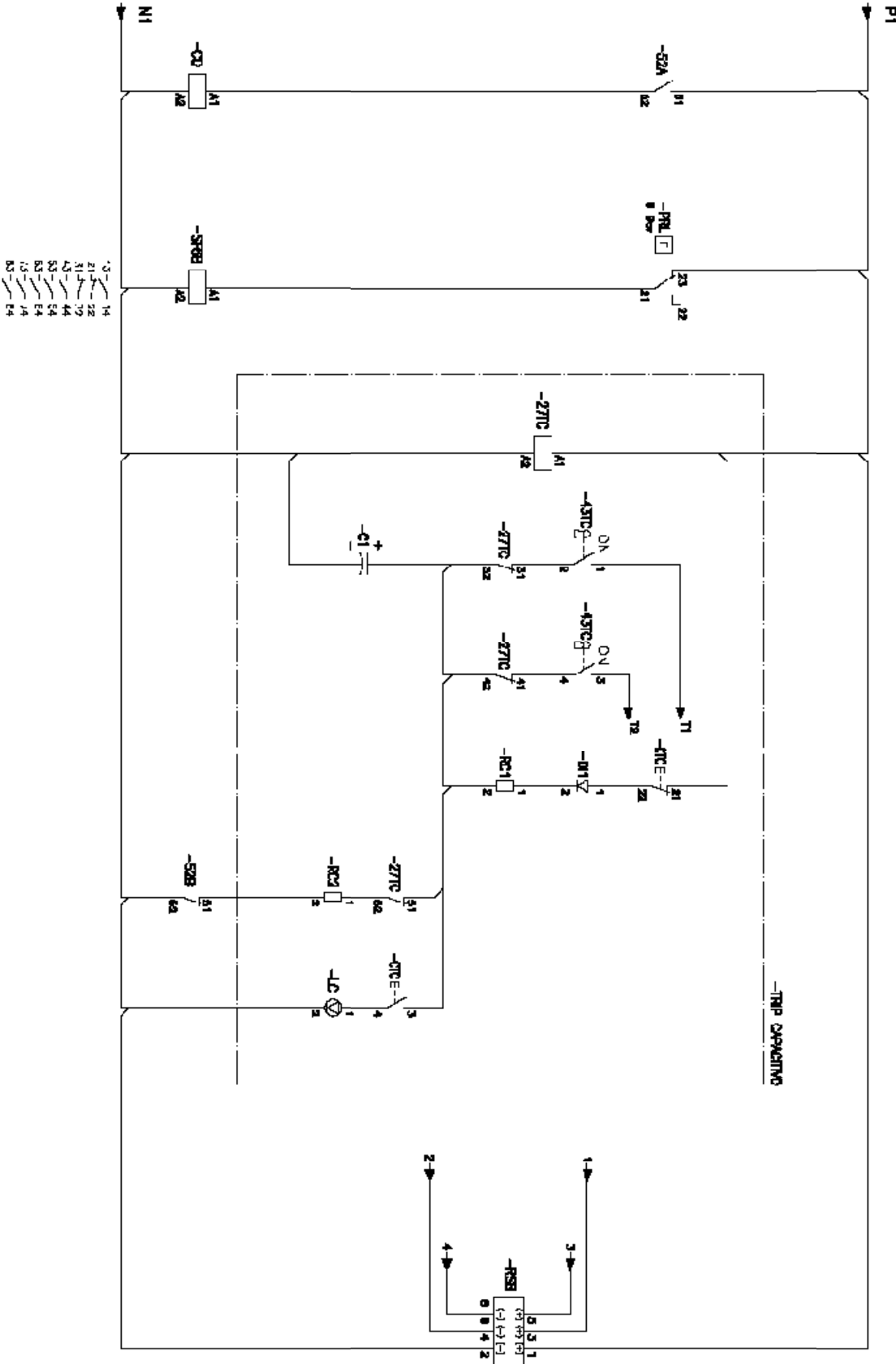



ALIMENTAÇÃO MOTOR - 125V/c	SUPERVISÃO TENSÃO MOTOR	CIRCUITO DE ILUMINAÇÃO, AQUECIMENTO E TOMADAS LAMPARA	TOMADA AQUECIMENTO
----------------------------	-------------------------	---	--------------------

CIRCUITO ELÉTRICO DISJUNTOR

LEGENDA

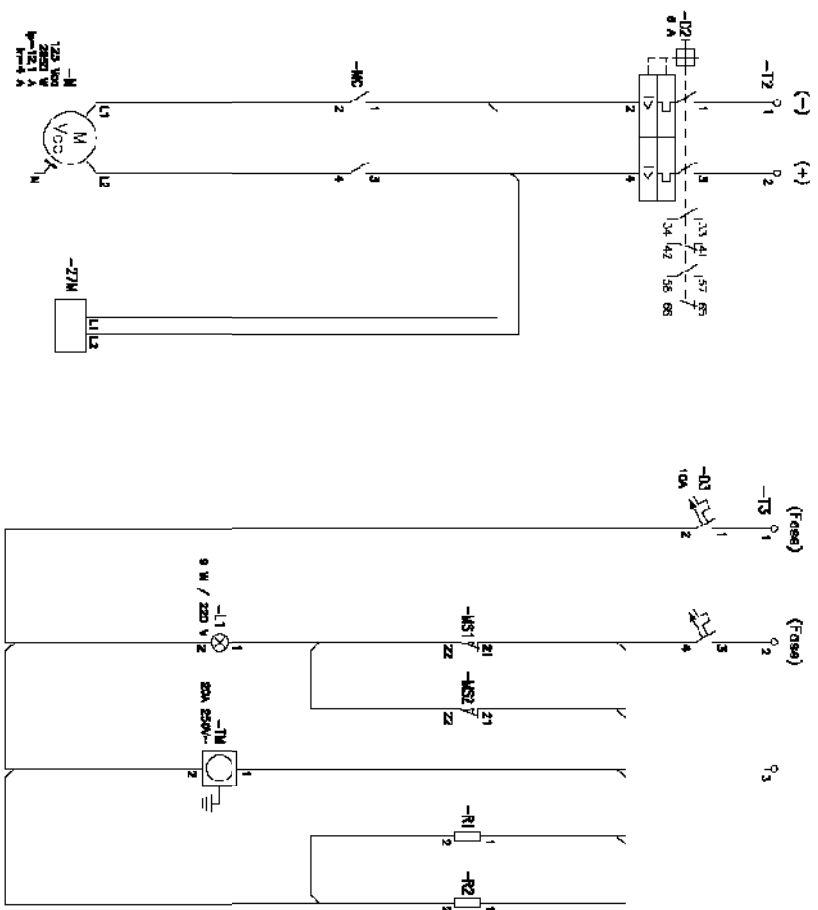

- LEGENDA:
- APR - RELE DE ANTI-PUMPING (ANTI-PUMPING RELAY)
 - BA1 - BOBINA DE ABERTURA 1 (OPENING COIL 1)
 - BA2 - BOBINA DE ABERTURA 2 (OPENING COIL 2)
 - BF - BOBINA DE FECHAMENTO (CLOSING COIL 1)
 - CA - COMANDO DE ABERTURA (OPENING COMMAND)
 - CF - COMANDO DE FECHAMENTO (CLOSING COMMAND)
 - CH1A - COMANDO MANUAL DE ABERTURA (MANUAL OPENING COMMAND)
 - CH1F - COMANDO MANUAL DE FECHAMENTO (MANUAL CLOSING COMMAND)
 - CO - CONTADOR DE OPERAÇÕES (OPERATING COUNTER)
 - CS1 - CHAVE SELEÇÃO LOCAL/RELETO (LOCAL/REMOTE SWITCH)
 - CTC - CHAVE TESTE TRIP CAPACITIVO (CAPACITIVE TRIP TEST KEY)
 - C1 - CAPACITOR DE TRIP CAPACITIVO (CAPACITIVE TRIP CAPACITOR)
 - C1A - CAPACITOR CIRCUITO DE ABERTURA 1 (OPENING CIRCUIT 1 CAPACITOR)
 - C2A - CAPACITOR CIRCUITO DE ABERTURA 2 (OPENING CIRCUIT 2 CAPACITOR)
 - D1 - DIODO DO CIRCUITO DE TRIP CAPACITIVO (CAPACITIVE TRIP DIODE)
 - D1 - MINIDISJUNTOR CIRCUITO DE COMANDO (CONTROL CIRCUIT BREAKER)
 - D2 - MINIDISJUNTOR CIRCUITO DE MOTOR (MOTOR CIRCUIT BREAKER)
 - D3 - MINIDISJUNTOR CIRCUITO AUXILIAR CA (AUXILIARY AC CIRCUIT BREAKER)
 - LD - LAMPADA DO CIRCUITO DE TRIP CAPACITIVO (CAPACITIVE TRIP LAMP)
 - L1, L2 - LAMPADAS DO ARMÁRIO DE CONTROLE (CONTROL LAMP AC)
 - M - MOTOR 125VCC (MOTOR 125VDC)
 - MC - MOLA CARREGADA (CHARGED SPRING)
 - MO - MOLA DESCARREGADA (UNCHARGED SPRING)
 - MS1,MS2 - MICROSWITCH DO CIRCUITO CA (AC CIRCUIT MICROSWITCH)
 - PS1,PS2 - PRESSOSTATO SFS (SFS PRESSURE SWITCH)
 - R1 - RESISTORES CIRCUITO DE TRIP CAPACITIVO (CAPACITIVE RESISTORS)
 - RSB - RELE DE SUPERVISÃO DE BOBINAS (COIL SUPERVISION RELAY)
 - RT1,RT2 - RESISTORES DE AQUECIMENTO (HEATING RESISTORS)
 - R1A - RESISTOR DO CIRCUITO DE ABERTURA 1 (OPENING CIRCUIT 1 RESISTOR)
 - R2A - RESISTOR DO CIRCUITO DE ABERTURA 2 (OPENING CIRCUIT 2 RESISTOR)
 - SFB - RELE DE BLOQUEIO DE SFS (SFS BLOCKING RELAY)
 - TM - TOMADA 220VCA (ELECTRICAL SOCKET 220VAC)
 - ZTM - RELE DE TENSÃO DO MOTOR (VOLTAGE SUPERVISION RELAY)
 - ZTTC - RELE DE TENSÃO DO CIRCUITO DE TRIP CAPACITIVO (CAPACITIVE TRIP VOLTAGE SUPERVISION RELAY)
 - 431G - CHAVE LIGA/DESLIGA TRIP CAPACITIVO (CAPACITIVE TRIP ON/OFF SWITCH)
 - 52A - DISJUNTOR FECHADO (CLOSED CIRCUIT BREAKER)
 - 52B - DISJUNTOR ABERTO (OPENED CIRCUIT BREAKER)



CODENSA

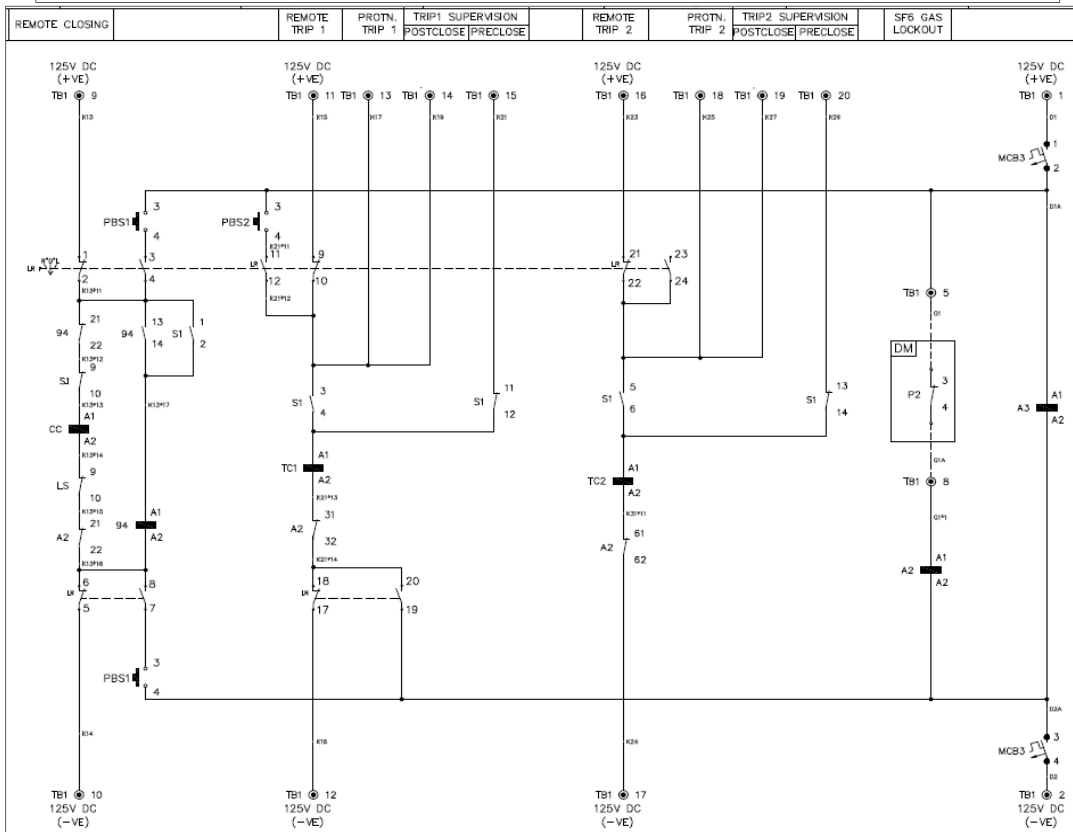
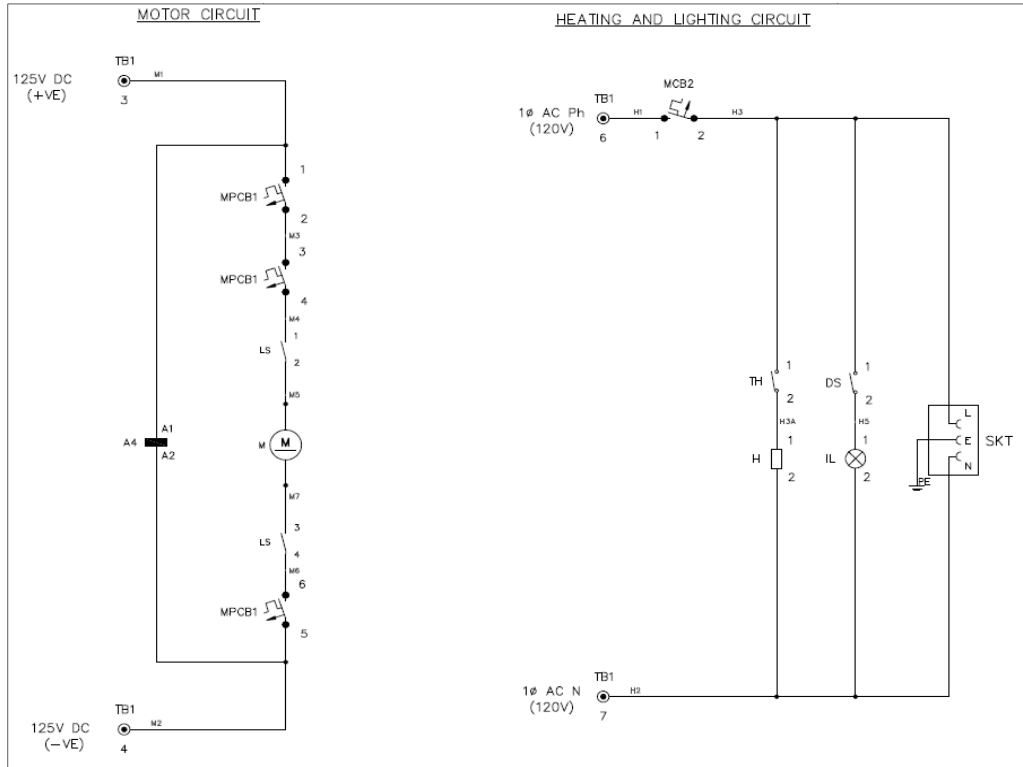

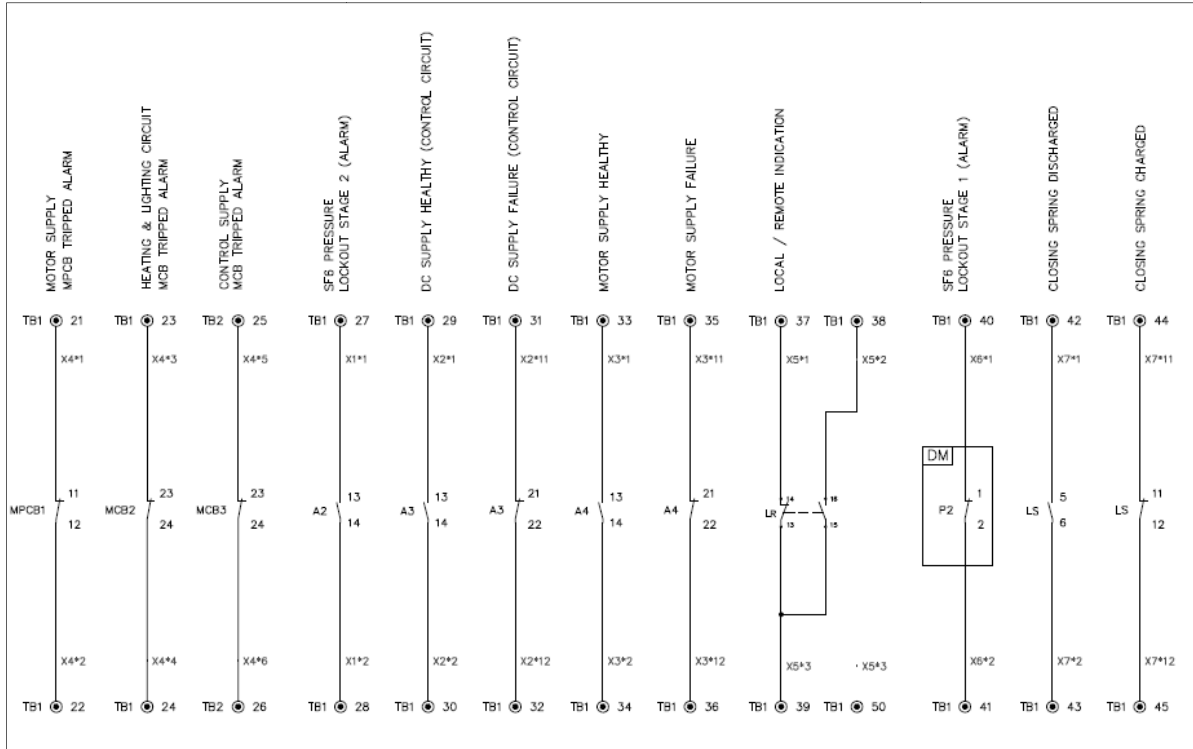

SPARE AUXILIARY CONTACTS (12NO + 12NC)

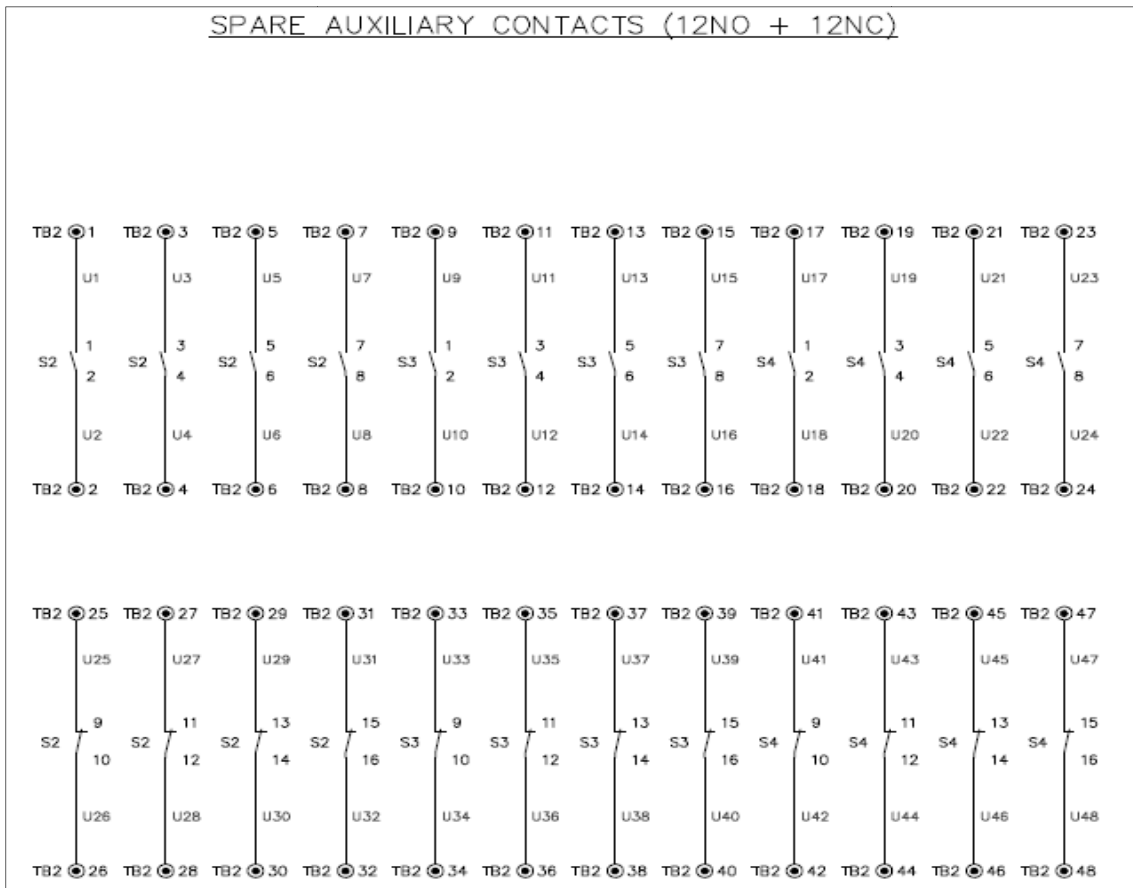



GLOBAL STANDARD

Page 55 of 57

HV CIRCUIT-BREAKERS

GSH001

Rev. 02

03/08/2017

EDELNOR

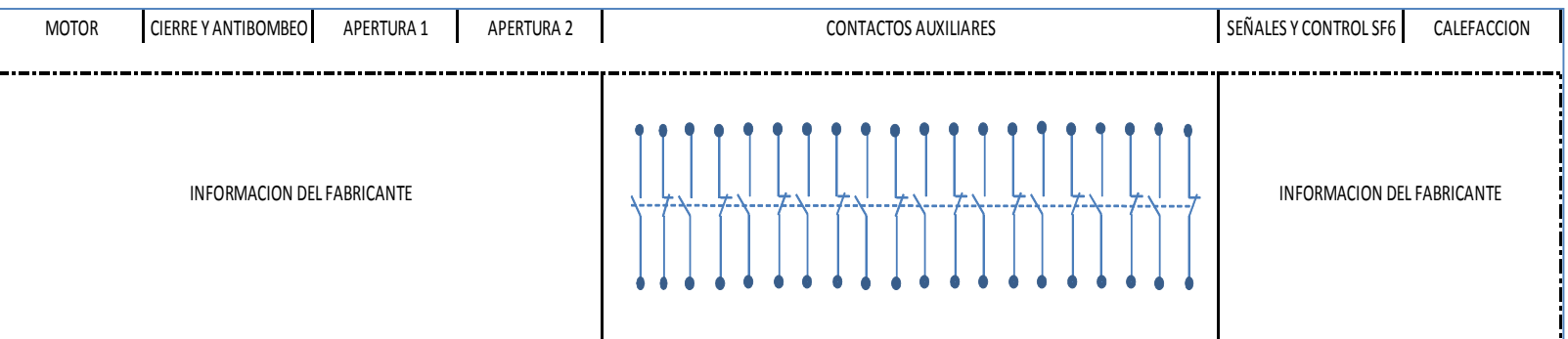



CHILECTRA:

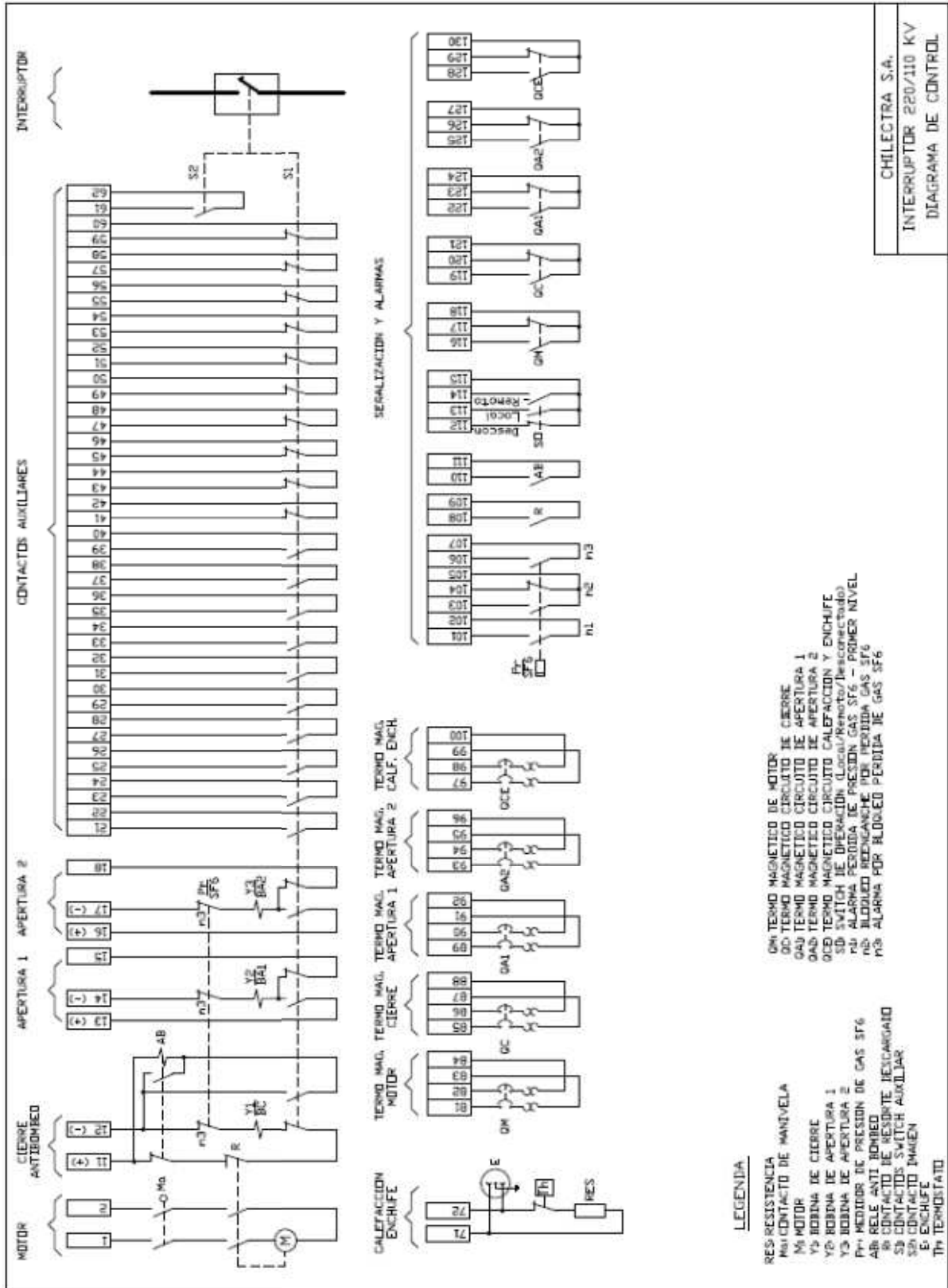

	GLOBAL STANDARD	Page 57 of 57
	HV CIRCUIT-BREAKERS	GSH001 Rev. 02 03/08/2017

ANNEX D – TENDER’S TECHNICAL DOCUMENTATION

GLOBAL STANDARD: GSH001 – HV Circuit Breakers	TENDER:	
SUPPLIER:	FACTORY:	
ENEL GROUP TYPE CODE: GSH001/___	SUPPLIER MODEL:	
TECHNICAL CHARACTERISTICS	STANDARD REQUIREMENT	SUPPLIER OFFER
<i>Service conditions</i>	outdoor normal service conditions of IEC 62271-1	
<i>Reference altitude (m)</i>	< 1.000 (2.600 for Colombia)	
<i>Minimum ambient air temperature (°C)</i>	-25 (-30° for Romania)	
<i>SPS Class (IEC/TS 60815 series)</i>	d) or e)	
<i>Ice coating (mm)</i>	10 (22 for Romania)	
<i>Seismic qualification level</i>	See table in 4.2.3	
<i>Arc-suppression medium</i>	SF6, non-fluorinated greenhouse gases or vacuum	
<i>Rated short-duration power-frequency withstand voltage Ud (kV rms)</i>		
<i>Rated lightning impulse withstand voltage Up (kVp)</i>		
<i>Rated frequency fr (Hz)</i>	50 or 60	
<i>Rated normal current Ir (A)</i>		
<i>Rated short-circuit breaking current Isc (kA)</i>		
<i>Type of operation</i>		
<i>First-pole-to-clear factor k_{pp}</i>		
<i>Rated operating sequence</i>	O - 0,3 s - CO - 1 min – CO	
<i>Maximum break-time (ms)</i>	60	
<i>Rated opening time (ms)</i>	-	
<i>Rated closing time (ms)</i>	-	
<i>Circuit breaker class</i>	C2 - E1 - M2	
<i>Rated line-charging breaking current II (A)</i>		
<i>Rated cable-charging breaking current Ic (A)</i>		
<i>Rated out-of-phase making and breaking current Id (kA)</i>	Clause 4.106 of IEC 62271-100	
<i>Auxiliary contact classes (Table 6 IEC 62271-1)</i>	1	
<i>Dimensions</i>	See Annex A	To enclose an overall equipment drawing for each Enel Group Distribution Company
<i>Insulators materials</i>	Composite or ceramic	