



**Technical Specification code: GRI-GRI-MAT-E&C-0007**

Version no. 6 dated 10/2022

**Subject:** Global Infrastructure and Networks - GSC002 LOW VOLTAGE UNDERGROUND CABLES WITH RATED VOLTAGE  $U_0/U(U_m)$  0,6/1,0(1,2) kV.

**Application Areas**

Perimeter: *Global*

Staff Function: -

Service Function: -

Business Line: *Infrastructure & Networks*

---

## CONTENTS

<b>1.DOCUMENT AIMS AND APPLICATION AREA</b>	<b>3</b>
<b>1.1 RELATED DOCUMENTS TO BE IMPLEMENTED AT COUNTRY LEVEL</b>	<b>3</b>
<b>2. DOCUMENT VERSION MANAGEMENT</b>	<b>4</b>
<b>3. UNITS IN CHARGE OF THE DOCUMENT</b>	<b>4</b>
<b>4. REFERENCES</b>	<b>4</b>
<b>5. ORGANIZATIONAL process POSITION IN THE PROCESS TAXONOMY</b>	<b>8</b>
<b>6. DEFINITIONS AND ACRONYMS</b>	<b>8</b>
<b>7. DESCRIPTION</b>	<b>9</b>
<b>7.1 List of Components</b>	<b>9</b>
<b>7.1.1. STANDARD CABLE</b>	<b>9</b>
<b>7.2 Service conditions</b>	<b>15</b>
<b>7.2.1. General service conditions</b>	<b>15</b>
<b>7.2.2. Specific service conditions</b>	<b>15</b>
<b>7.3 Technical characteristics</b>	<b>15</b>
<b>7.3.1. Type of cables</b>	<b>15</b>
<b>7.4 CONSTRUCTION CHARACTERISTICS</b>	<b>17</b>
<b>7.4.1. CONDUCTOR</b>	<b>17</b>
<b>7.4.2. INSULATION</b>	<b>20</b>
<b>7.4.3. Outer Sheath</b>	<b>21</b>
<b>7.5 CONSTRUCTIVE ASPECT</b>	<b>22</b>
<b>7.6 Ampacity and Short-circuit rating</b>	<b>22</b>



**Technical Specification code: GRI-GRI-MAT-E&C-0007**

Version no. 6 dated 10/2022

**Subject:** Global Infrastructure and Networks - GSC002 LOW VOLTAGE UNDERGROUND CABLES WITH RATED VOLTAGE  $U_0/U(U_m)$  0,6/1,0(1,2) kV.

**Application Areas**

Perimeter: *Global*

Staff Function: -

Service Function: -

Business Line: *Infrastructure & Networks*

---

<b>7.7 Marking and designation of the cable</b>	<b>22</b>
<b>7.7.1. Cable designation</b>	<b>22</b>
<b>7.7.2. Marking</b>	<b>22</b>
<b>7.8 TESTING</b>	<b>23</b>
<b>7.8.1. Acceptance tests</b>	<b>23</b>
<b>7.8.2. Sampling and acceptance criteria</b>	<b>24</b>
<b>7.8.3. Repetitiqn of acceptance tests carried out in presence of Enel's inspector or designate</b>	<b>25</b>
<b>7.8.4. Sampling and acceptance criteria</b>	<b>25</b>
<b>7.8.5. Type test</b>	<b>26</b>
<b>7.9 TECHNICAL CONFORMITY ASSESSMENT</b>	<b>31</b>
<b>7.9.1 General conditions</b>	<b>31</b>
<b>7.9.2 Acknowledgement of TCA for previous revision of the standard.</b>	<b>31</b>
<b>8 LOCAL SECTION</b>	<b>32</b>
<b>9 Annexes</b>	<b>52</b>
<b>9.1 Check list 3x240+150</b>	<b>52</b>
<b>9.2 check list 1x240 type I</b>	<b>54</b>
<b>9.3 check list 1x240 type III</b>	<b>56</b>

**THE HEAD OF NETWORK COMPONENTS**  
**Fabrizio Gasbarri**

**Application Areas**

Perimeter: *Global*

Staff Function: -

Service Function: -

Business Line: *Infrastructure & Networks*

## 1. DOCUMENT AIMS AND APPLICATION AREA

The aim of this document is to provide technical requirements for the supply of underground low voltage cables to be used in the distribution networks.

These Global Standard applies to the Distribution Companies of Enel Group listed below:

Country	Distribution Company
Argentina	Edesur
Brazil	Enel Distribuição Rio (RJ) Enel Distribuição Ceará (CE) Enel Distribuição Goiás (GO) Enel Distribuição São Paulo (SP)
Chile	Enel Distribución Chile
Colombia	Codensa
Iberia	E-distribución
Italy	E-distribuzione
Perú	Enel Distribución Perú
Romania	E-distributie Banat E-distributie Dobrogea E-distributie Muntenia

### Distribution Companies

This standard specifies the construction, dimensions and test requirements that must be accomplished by underground low voltage distribution cables with rated voltage  $U_0/U(U_{max})= 0,6/1 (1,2)$  kV used in distribution systems by the utilities mentioned above.

This standard replaces all the local standards used up to now by all the Distribution Companies, as long as local regulation allows it.

#### 1.1 RELATED DOCUMENTS TO BE IMPLEMENTED AT COUNTRY LEVEL

This document applies to both Enel Global Infrastructure and Networks Srl Company and to Infrastructure and Networks Business Line perimeter, when each Company does not have to issue further documents.

## 2. DOCUMENT VERSION MANAGEMENT

Version	Date	Main changes description
00	30/01/2014	First emission.
01	30/11/2014	Second emission
02	19/02/2015	Third emission
03	03/12/2017	Updates common list
04	15/01/2018	Forth emission Cable Type Optimization Addition of CPR requirements Addition of technical check-list Optimization of common list
05	11/2018	Country codes included in the Common list
06	09/2022	Type code standardization Country codes included in the Common list

## 3. UNITS IN CHARGE OF THE DOCUMENT

Responsible for drawing up the document:

- Global Infrastructure and Networks: Engineering and Construction / Components and Devices Design unit / Network Components unit

Responsible for authorizing the document:

- Global Infrastructure and Networks: Head of Network Components unit
- Global Infrastructure and Networks: Head of Quality unit.

## 4. REFERENCES

- Enel Group Code of Ethics;
- The Enel Group Zero Corruption Tolerance (ZCT) Plan;
- Organizational and management model as per Italian Legislative Decree no. 231/2001 or equivalent documents adopted in the Countries;
- Enel Human Rights Policy;
- Stop Work Policy;
- Enel Global Compliance Program (EGCP);
- Integrated Policy of Quality, Health and Safety, Environment and anti-Bribery;
- ISO 9001:2015 - Quality Management System - Requirements;
- ISO 14001:2015 - Environmental Management System - Requirements and user guide;

**Application Areas**Perimeter: *Global*

Staff Function: -

Service Function: -

Business Line: *Infrastructure & Networks*

- ISO 45001:2018 - Occupational Health and Safety Management System - Requirements and user guide;
- ISO 50001:2018 - Energy management systems - Requirements with guidance for use;
- ISO 37001:2016 - Anti-bribery Management System - Requirements with guidance for use.
- MAT-O&M-NCS-2021-0033-EGIN version 3 “Global Infrastructure and Networks – GSCG002 Technical Conformity Assessment”.
- CNS-O&M-S&L-2021-0032-EGIN “Global Infrastructure and Networks Barcode specification.”

**GLOBAL STANDARDS****LAWS***Brazil*

- *NR-10 - Segurança em Instalações e Serviços em Eletricidade*

*Chile*

- *NSEG 5 En.71 Reglamento de Instalaciones Eléctricas de Corrientes Fuertes.*

*Colombia*

- *RETIE, Reglamento Técnico de Instalaciones Eléctricas.*
- *Código Eléctrico Colombiano, NTC 2050*

*Peru*

- *Código Nacional de Electricidad – Suministro 2011.*
- *Norma Técnica de Calidad de los servicios eléctricos (NTCSE)*

*Romania*

- *NTE007/08/00 Normativ pentru proiectare și executarea rețelelor de cabluri electrice*

*Spain*

- *R.D. 614/2001, de 8 de junio, sobre disposiciones mínimas para la protección de la salud y seguridad de los trabajadores frente al riesgo eléctrico.*
- *REAL DECRETO 842/2002, de 2 de agosto, por el que se aprueba el Reglamento Electrotécnico para Baja Tensión e Instrucciones Técnicas Complementarias (R.E.B.T.)*

**Application Areas**

 Perimeter: *Global*

Staff Function: -

Service Function: -

 Business Line: *Infrastructure & Networks*

- *R.D. 337/2014, de 9 de mayo, por el que se aprueban el Reglamento sobre condiciones técnicas y garantías de seguridad en instalaciones eléctricas de alta tensión y sus Instrucciones Técnicas Complementarias ITC-RAT 01 a 23.*
- *Reglamento (UE) nº 305/2011 del Parlamento Europeo y del Consejo, de 9 de marzo de 2011, por el que se establecen condiciones armonizadas para la comercialización de productos de construcción y se deroga la Directiva 89/106/CEE del Consejo.*

**EUROPEAN & INTERNATIONAL STANDARDS**

- *EN13501-6 “Fire classification of construction products and building elements - Part 6: Classification using data from reaction to fire tests on electric cables”.*
- *EN 50575 “Power, control and communication cables - Cables for general applications in construction works subject to reaction to fire requirements”*
- *HD 603 “Distribution cables of rated voltage 0,6/1 kV”*
- *HD 605 “Electric cables - Additional test methods”*
- *IEC 60228: “Conductors of insulated cables”*
- *IEC 60410: Sampling plans and procedures for inspection by attributes.*
- *IEC 60502-1:” Power cables with extruded insulation and their accessories for rated voltages from 1 kV up to 30 kV – Part 1: cables for rated voltages of 1 kV and 3 kV”*
- *IEC 60332-1-2 “Tests on electric and optical fibre cables under fire conditions Part 1-2: Test for vertical flame propagation for a single insulated wire or cable - Procedure for 1 kW pre-mixed flame”*
- *IEC 60754-1 “Test on gases evolved during combustion of materials from cables - Part 1: Determination of the halogen acid gas content”*
- *IEC 60754-2 “Test on gases evolved during combustion of materials from cables - Part 2: Determination of acidity (by pH measurement) and conductivity”*
- *IEC 60811-100 “Electric and optical fibre cables - Test methods for non-metallic materials-Part 100: General”*
- *IEC 60811-201 “Electric and optical fibre cables - Test methods for non-metallic materials-Part 201: General tests - Measurement of insulation thickness”*
- *IEC 60811-202 “Electric and optical fibre cables - Test methods for non-metallic materials-Part 202: General tests - Measurement of thickness of non-metallic sheath”*
- *IEC 60811-203 “Electric and optical fibre cables - Test methods for non-metallic materials-Part 203: General tests - Measurement of overall dimensions”*
- *IEC 60811-401 “Electric and optical fibre cables - Test methods for non-metallic materials-Part 401: Miscellaneous tests - Thermal ageing methods - Ageing in an air oven”*

**Application Areas**Perimeter: *Global*

Staff Function: -

Service Function: -

Business Line: *Infrastructure & Networks*

- IEC 60811-402 “Electric and optical fibre cables - Test methods for non-metallic materials-Part 402: Miscellaneous tests - Water absorption tests”
- IEC 60811-403 “Electric and optical fibre cables - Test methods for non-metallic materials-Part 403: Miscellaneous tests - Ozone resistance tests on cross-linked compounds”
- IEC 60811-409 “Electric and optical fibre cables - Test methods for non-metallic materials Part 409: Miscellaneous tests - Loss of mass test for thermoplastic insulations and sheaths
- IEC 60811-501 “Electric and optical fibre cables - Test methods for non-metallic materials-Part 501: Mechanical tests - Tests for determining the mechanical properties of insulating and sheathing compounds”
- IEC 60811-502 “Electric and optical fibre cables - Test methods for non-metallic materials Part 502: Mechanical tests - Shrinkage test for insulations”
- IEC 60811-503 “Electric and optical fibre cables - Test methods for non-metallic materials Part 503: Mechanical tests - Shrinkage test for sheaths”
- IEC 60811-504 “Electric and optical fibre cables - Test methods for non-metallic materials-Part 504: Mechanical tests - Bending tests at low temperature for insulation and sheaths”
- IEC 60811-505 “Electric and optical fibre cables - Test methods for non-metallic materials-Part 505: Mechanical tests - Elongation at low temperature for insulations and sheaths”
- IEC 60811-506 “Electric and optical fibre cables - Test methods for non-metallic materials-Part 506: Mechanical tests - Impact test at low temperature for insulations and sheaths”
- IEC 60811-507 “Electric and optical fibre cables - Test methods for non-metallic materials-Part 507: Mechanical tests - Hot set test for cross-linked materials”
- IEC 60811-508 “Electric and optical fibre cables - Test methods for non-metallic materials Part 508: Mechanical tests - Pressure test at high temperature for insulation and sheaths”
- IEC 60811-605 “Electric and optical fibre cables - Test methods for non-metallic materials-Part 605: Physical tests - Measurement of carbon black and/or mineral filler in polyethylene compounds”
- IEC 61034-2 “Measurement of smoke density of cables burning under defined conditions - Part 2: Test procedure and requirements”
- IEC 62230 “Electric cables - Spark-test method”
- ISO 2859-0 “Sampling procedures for inspection by attributes -- Part 0: Introduction to the ISO 2859 attribute sampling system”
- ISO 2859-1 “Sampling procedures for inspection by attributes -- Part 1: Sampling schemes indexed by acceptance quality limit (AQL) for lot-by-lot inspection”
- Reglamentación AEA 95101 Versión 2015 Líneas Subterráneas Exteriores de Energía y Telecomunicaciones

### **LOCAL STANDARDS**

See local section

### **REPLACED LOCAL STANDARDS**

See local section

## **5. ORGANIZATIONAL PROCESS POSITION IN THE PROCESS TAXONOMY**

Value Chain/Process Area: Networks Management

Macro Process: Materials management

Process: Network Components Standardization

## **6. DEFINITIONS AND ACRONYMS**

<b>Acronym and Key words</b>	<b>Description</b>
<b>Acceptable Quality Level (AQL)</b>	The maximum percentage of malfunctions that can be detected during a sample inspection and can still be considered satisfactory
<b>Low Voltage (LV)</b>	Any set of nominal voltage levels in the range 0,5 to 1 kV AC or 120 to 1500 V DC
<b>Technical Conformity Assessment (TCA)</b>	A "conformity assessment" with respect to "specified requirements" <sup>1</sup> consists in functional, dimensional, constructional and test characteristics required for a product (or a series of products) and quoted in technical specifications and quality requirements issued by Enel Group distribution companies. This also includes the verification of conformity with respect to local applicable regulation and laws and possession of relevant requested certifications

**Table 1**



**Application Areas**

 Perimeter: *Global*

Staff Function: -

Service Function: -

 Business Line: *Infrastructure & Networks*
**7. DESCRIPTION**
**7.1 LIST OF COMPONENTS**
**7.1.1.STANDARD CABLE**

GS Code	Type	Distribution Company	Country Code	Cross-section	Type of cable	Conductor material	Minimum Number of Wires of Conductor	Minimum conductor diameter [mm]	Maximum conductor diameter [mm]	Insulation material	Nominal insulation thickness [mm]	Minimum insulation thickness [mm]	Outer sheath material	Sheath nominal thickness [mm]	Sheath minimum thickness [mm]	Sheath Colour	Constructive Characteristics	Neutral
GSC002/001		PE	340172	10	I	ALUMINUM	6	3,6	4,2	XLPE/HPTE	0,7	0,53	PO	1,3	1,01	Black	Unipolar	-
GSC002/002		BR	330982	16	I	ALUMINUM	6	4,6	5,2	XLPE/HPTE	0,7	0,53	PO	1,3	1,01	Black	Unipolar	-
GSC002/002		CL	330279	16	I	ALUMINUM	6	4,6	5,2	XLPE/HPTE	0,7	0,53	PO	1,3	1,01	Black	Unipolar	-
GSC002/002		PE	330038	16	I	ALUMINUM	6	4,6	5,2	XLPE/HPTE	0,7	0,53	PO	1,3	1,01	Black	Unipolar	-
GSC002/002		BR SP	325016	16	I	ALUMINUM	6	4,6	5,2	XLPE/HPTE	0,7	0,53	PO	1,3	1,01	Black	Unipolar	-
GSC002/002		AR	0101-0520	16	I	ALUMINUM	6	4,6	5,2	XLPE/HPTE	0,7	0,53	PO	1,3	1,01	Black	Unipolar	-
GSC002/003		PE	340173	25	I	ALUMINUM	6	5,6	6,5	XLPE/HPTE	0,9	0,71	PO	1,3	1,01	Black	Unipolar	-
GSC002/003		IT	330301	25	I	ALUMINUM	6	5,6	6,5	XLPE/HPTE	0,9	0	PO	1,3	1,01	Black	Unipolar	-
GSC002/003		RO	330301	25	I	ALUMINUM	6	5,6	6,5	XLPE/HPTE	0,9	0,71	PO	1,3	1,01	Black	Unipolar	-
GSC002/003		CO	330663	25	I	AA-8000	6	5,6	6,5	XLPE/HPTE	0,9	0,71	PO	1,3	1,01	Black	Unipolar	-
GSC002/003		CL	330280	25	I	ALUMINUM	6	5,6	6,5	XLPE/HPTE	0,9	0,71	PO	1,3	1,01	Black	Unipolar	-
GSC002/003		BR	330988	25	I	ALUMINUM	6	5,6	6,5	XLPE/HPTE	0,9	0,71	PO	1,3	1,01	Black	Unipolar	-
GSC002/004		PE	340174	35	I	ALUMINUM	6	6,6	7,5	XLPE/HPTE	0,9	0,71	PO	1,3	1,01	Black	Unipolar	-

**Application Areas**

 Perimeter: *Global*

Staff Function: -

Service Function: -

 Business Line: *Infrastructure & Networks*

GS Code	Type	Distribution Company	Country Code	Cross-section	Type of cable	Conductor material	Minimum Number of Wires of Conductor	Minimum conductor diameter [mm]	Maximum conductor diameter [mm]	Insulation material	Nominal insulation thickness [mm]	Minimum insulation thickness [mm]	Outer sheath material	Sheath nominal thickness [mm]	Sheath minimum thickness [mm]	Sheath Colour	Constructive Characteristics	Neutral
GSC002/004		BR	330148	35	I	ALUMINUM	6	6,6	7,5	XLPE/HPTE	0,9	0,71	PO	1,3	1,01	Black	Unipolar	-
GSC002/004		BR SP	325015	35	I	ALUMINUM	6	6,6	7,5	XLPE/HPTE	0,9	0,71	PO	1,3	1,01	Black	Unipolar	-
GSC002/005		ES	330006	50	I	ALUMINUM	6	7,7	8,6	XLPE/HPTE	1	0,8	PO	1,3	1,01	Black	Unipolar	-
GSC002/005		IT	330302	50	I	ALUMINUM	6	7,7	8,6	XLPE/HPTE	1	0,8	PO	1,3	1,01	Black	Unipolar	-
GSC002/005		RO	330302	50	I	ALUMINUM	6	7,7	8,6	XLPE/HPTE	1	0,8	PO	1,3	1,01	Black	Unipolar	-
GSC002/005		BR	330989	50	I	ALUMINUM	6	7,7	8,6	XLPE/HPTE	1	0,8	PO	1,3	1,01	Black	Unipolar	-
GSC002/005		CO	330088	50	I	AA-8000	6	7,7	8,6	XLPE/HPTE	1	0,8	PO	1,3	1,01	Black	Unipolar	-
GSC002/005		CL	330093	50	I	ALUMINUM	6	7,7	8,6	XLPE/HPTE	1	0,8	PO	1,3	1,01	Black	Unipolar	-
GSC002/005		PE	330037	50	I	ALUMINUM	6	7,7	8,6	XLPE/HPTE	1	0,8	PO	1,3	1,01	Black	Unipolar	-
GSC002/005		AR	0101-0522	50	I	ALUMINUM	6	7,7	8,6	XLPE/HPTE	1	0,8	PO	1,3	1,01	Black	Unipolar	-
GSC002/006		ES	330007	95	I	ALUMINUM	15	11	12	XLPE/HPTE	1,1	0,89	PO	1,4	1,09	Black	Unipolar	-
GSC002/006		IT	330303	95	I	ALUMINUM	15	11	12	XLPE/HPTE	1,1	0,89	PO	1,4	1,09	Black	Unipolar	-
GSC002/006		RO	330303	95	I	ALUMINUM	15	11	12	XLPE/HPTE	1,1	0,89	PO	1,4	1,09	Black	Unipolar	-

**Application Areas**

 Perimeter: *Global*

Staff Function: -

Service Function: -

 Business Line: *Infrastructure & Networks*

GS Code	Type	Distribution Company	Country Code	Cross-section	Type of cable	Conductor material	Minimum Number of Wires of Conductor	Minimum conductor diameter [mm]	Maximum conductor diameter [mm]	Insulation material	Nominal insulation thickness [mm]	Minimum insulation thickness [mm]	Outer sheath material	Sheath nominal thickness [mm]	Sheath minimum thickness [mm]	Sheath Colour	Constructive Characteristics	Neutral
GSC002/006		BR	330089	95	I	ALUMINUM	15	11	12	XLPE/HPTE	1,1	0,89	PO	1,4	1,09	Black	Unipolar	-
GSC002/006		BR SP	325014	95	I	ALUMINUM	15	11	12	XLPE/HPTE	1,1	0,89	PO	1,4	1,09	Black	Unipolar	-
GSC002/006		CO	330074	95	I	AA-8000	15	11	12	XLPE/HPTE	1,1	0,89	PO	1,4	1,09	Black	Unipolar	-
GSC002/006		CL	330094	95	I	ALUMINUM	15	11	12	XLPE/HPTE	1,1	0,89	PO	1,4	1,09	Black	Unipolar	-
GSC002/006		PE	330036	95	I	ALUMINUM	15	11	12	XLPE/HPTE	1,1	0,89	PO	1,4	1,09	Black	Unipolar	-
GSC002/007		ES	330008	150	I	ALUMINUM	15	13,7	15	XLPE/HPTE	1,4	1,16	PO	1,4	1,09	Black	Unipolar	-
GSC002/007		PE	340176	150	I	ALUMINUM	15	13,7	15	XLPE/HPTE	1,4	1,16	PO	1,4	1,09	Black	Unipolar	-
GSC002/007		IT	330304	150	I	ALUMINUM	15	13,7	15	XLPE/HPTE	1,4	1,16	PO	1,4	1,09	Black	Unipolar	-
GSC002/007		RO	330304	150	I	ALUMINUM	15	13,7	15	XLPE/HPTE	1,4	1,16	PO	1,4	1,09	Black	Unipolar	-
GSC002/007		CO	330662	150	I	AA-8000	15	13,7	15	XLPE/HPTE	1,4	1,16	PO	1,4	1,09	Black	Unipolar	-
GSC002/007		CL	330282	150	I	ALUMINUM	15	13,7	15	XLPE/HPTE	1,4	1,16	PO	1,4	1,09	Black	Unipolar	-
GSC002/007		BR	330987	150	I	ALUMINUM	15	13,7	15	XLPE/HPTE	1,4	1,16	PO	1,4	1,09	Black	Unipolar	-
GSC002/008		ES	330009	240	I	ALUMINUM	30	17,6	19,2	XLPE/HPTE	1,7	1,43	PO	1,5	1,175	Black	Unipolar	-

**Application Areas**

 Perimeter: *Global*

Staff Function: -

Service Function: -

 Business Line: *Infrastructure & Networks*

GS Type Code	Distribution Company	Country Code	Cross-section	Type of cable	Conductor material	Minimum Number of Wires of Conductor	Minimum conductor diameter [mm]	Maximum conductor diameter [mm]	Insulation material	Nominal insulation thickness [mm]	Minimum insulation thickness [mm]	Outer sheath material	Sheath nominal thickness [mm]	Sheath minimum thickness [mm]	Sheath Colour	Constructive Characteristics	Neutral
GSC002/008	PE	340177	240	I	ALUMINUM	30	17,6	19,2	XLPE/HPTE	1,7	1,43	PO	1,5	1,175	Black	Unipolar	-
GSC002/008	IT	330305	240	I	ALUMINUM	30	17,6	19,2	XLPE/HPTE	1,7	1,43	PO	1,5	1,175	Black	Unipolar	-
GSC002/008	RO	330305	240	I	ALUMINUM	30	17,6	19,2	XLPE/HPTE	1,7	1,43	PO	1,5	1,175	Black	Unipolar	-
GSC002/008	BR	330983	240	I	ALUMINUM	30	17,6	19,2	XLPE/HPTE	1,7	1,43	PO	1,5	1,175	Black	Unipolar	-
GSC002/008	CO	330664	240	I	AA-8000	30	17,6	19,2	XLPE/HPTE	1,7	1,43	PO	1,5	1,175	Black	Unipolar	-
GSC002/008	CL	330283	240	I	ALUMINUM	30	17,6	19,2	XLPE/HPTE	1,7	1,43	PO	1,5	1,175	Black	Unipolar	-
GSC002/008	BR	323864	240	I	ALUMINUM	30	17,6	19,2	XLPE/HPTE	1,7	1,43	PO	1,5	1,175	Black	Unipolar	-
GSC002/009	RO	330655	95	II	ALUMINUM	15	11	12	XLPE/HPTE	1,1	0,89	PO	1,4	1,09	Black	Quadripolar	Same as GSC002/005
GSC002/009	AR	0101-0487	95	II	ALUMINUM	15	11	12	XLPE/HPTE	1,1	0,89	PO	1,4	1,09	Black	Quadripolar	Same as GSC002/005
GSC002/010	IT	330656	150	II	ALUMINUM	15	13,7	15	XLPE/HPTE	1,4	1,16	PO	1,4	1,09	Black	Quadripolar	Same as GSC002/006
GSC002/010	RO	330656	150	II	ALUMINUM	15	13,7	15	XLPE/HPTE	1,4	1,16	PO	1,4	1,09	Black	Quadripolar	Same as GSC002/006
GSC002/010	AR	0101-0502	150	II	ALUMINUM	15	13,7	15	XLPE/HPTE	1,4	1,16	PO	1,4	1,09	Black	Quadripolar	Same as GSC002/006
GSC002/011	IT	330657	240	II	ALUMINUM	30	17,6	19,2	XLPE/HPTE	1,7	1,43	PO	1,5	1,175	Black	Quadripolar	Same as GSC002/007

**Application Areas**

 Perimeter: *Global*

Staff Function: -

Service Function: -

 Business Line: *Infrastructure & Networks*

GS Code	Type	Distribution Company	Country Code	Cross-section	Type of cable	Conductor material	Minimum Number of Wires of Conductor	Minimum conductor diameter [mm]	Maximum conductor diameter [mm]	Insulation material	Nominal insulation thickness [mm]	Minimum insulation thickness [mm]	Outer sheath material	Sheath nominal thickness [mm]	Sheath minimum thickness [mm]	Sheath Colour	Constructive Characteristics	Neutral
GSC002/011		RO	330657	240	II	ALUMINUM	30	17,6	19,2	XLPE/HPTE	1,7	1,43	PO	1,5	1,175	Black	Quadripolar	Same as GSC002/007
GSC002/011		AR	0101-0488	240	II	ALUMINUM	30	17,6	19,2	XLPE/HPTE	1,7	1,43	PO	1,5	1,175	Black	Quadripolar	Same as GSC002/007
GSC002/012		CL	350083	400	I	ALUMINUM	53	22,3	24,6	XLPE/HPTE	2	1,7	PO	1,9	1,5	Black	Unipolar	
GSC002/012		PE	340171	400	I	ALUMINUM	53	22,3	24,6	XLPE/HPTE	2	1,7	PO	1,9	1,5	Black	Unipolar	
GSC002/012		BR	331062	400	I	ALUMINUM	53	22,3	24,6	XLPE/HPTE	2	1,7	PO	1,9	1,5	Black	Unipolar	-
GSC002/013		IT	330007	150	III	COPPER	18	13,7	15	XLPE/HPTE	1,4	1,16	PO	1,4	1,09	Black	Unipolar	
GSC002/013		AR	0101-0371	150	III	COPPER	18	13,7	15	XLPE/HPTE	1,4	1,16	PO	1,4	1,09	Black	Unipolar	
GSC002/013		RO	330007	150	III	COPPER	18	13,7	15	XLPE/HPTE	1,4	1,16	PO	1,4	1,09	Black	Unipolar	
GSC002/013		BR	330248	150	III	COPPER	18	13,7	15	XLPE/HPTE	1,4	1,16	PO	1,4	1,09	Black	Unipolar	-
GSC002/013		CL	330258	150	III	COPPER	18	13,7	15	XLPE/HPTE	1,4	1,16	PO	1,4	1,09	Black	Unipolar	
GSC002/013		PE	330091	150	III	COPPER	18	13,7	15	XLPE/HPTE	1,4	1,16	PO	1,4	1,09	Black	Unipolar	
GSC002/014		IT	330008	240	III	COPPER	34	17,6	19,2	XLPE/HPTE	1,7	1,43	PO	1,5	1,175	Black	Unipolar	
GSC002/014		RO	330008	240	III	COPPER	34	17,6	19,2	XLPE/HPTE	1,7	1,43	PO	1,5	1,175	Black	Unipolar	

**Application Areas**

 Perimeter: *Global*

Staff Function: -

Service Function: -

 Business Line: *Infrastructure & Networks*

GS Code	Type	Distribution Company	Country Code	Cross-section	Type of cable	Conductor material	Minimum Number of Wires of Conductor	Minimum conductor diameter [mm]	Maximum conductor diameter [mm]	Insulation material	Nominal insulation thickness [mm]	Minimum insulation thickness [mm]	Outer sheath material	Sheath nominal thickness [mm]	Sheath minimum thickness [mm]	Sheath Colour	Constructive Characteristics	Neutral
GSC002/014		CL	330255	240	III	COPPER	34	17,6	19,2	XLPE/HPTE	1,7	1,43	PO	1,5	1,175	Black	Unipolar	
GSC002/014		PE	330590	240	III	COPPER	34	17,6	19,2	XLPE/HPTE	1,7	1,43	PO	1,5	1,175	Black	Unipolar	
GSC002/014		BR	323477	240	III	COPPER	34	17,6	19,2	XLPE/HPTE	1,7	1,43	PO	1,5	1,175	Black	Unipolar	-
GSC002/014		BR	323477	240	III	COPPER	34	17,6	19,2	XLPE/HPTE	1,7	1,43	PO	1,5	1,175	Black	Unipolar	-
GSC002/015		BR	330245	400	III	COPPER	53	22,3	24,6	XLPE/HPTE	2	1,7	PO	1,9	1,5	Black	Unipolar	-
GSC002/015		BR SP	323478	400	III	COPPER	53	22,3	24,6	XLPE/HPTE	2	1,7	PO	1,9	1,5	Black	Unipolar	
GSC002/016		BR	330247	630	III	COPPER	53	28,7	32,5	XLPE/HPTE	2,4	2,06	PO	2,2	1,77	Black	Unipolar	-
GSC002/016		BR SP	323479	630	III	COPPER	53	28,7	32,5	XLPE/HPTE	2,4	2,06	PO	2,2	1,77	Black	Unipolar	-

## 7.2 SERVICE CONDITIONS

### 7.2.1. General service conditions

See local section

### 7.2.2. Specific service conditions

Colombia (Enel Distribución Colombia): the reference altitude is 2.700 m

## 7.3 TECHNICAL CHARACTERISTICS

### 7.3.1. Type of cables

The typical layout of cable is shown in Figure 1, in Figure 2 and Figure 3.

The different parts of the cables are depicted in section 7.4.

In Table 1 Types of cables specified in this document are briefly depicted.

TYPE	DESCRIPTION
I	Unipolar cable with aluminum conductor, cross-linked polyethylene or high performance polypropylene thermoplastic elastomer insulation (XLPE/HPTE) and polyolefin (PO) outer sheath. Class E <sub>ca</sub> according to EN 50575*
II	Helically bundled tetra polar cable with aluminum conductor, cross-linked polyethylene or high performance polypropylene thermoplastic elastomer insulation (XLPE/HPTE) and polyolefin (PO) outer sheath. Class E <sub>ca</sub> according to EN 50575*
III	Unipolar cable with copper conductor, cross-linked polyethylene or high performance polypropylene thermoplastic elastomer insulation (XLPE/HPTE) and polyolefin (PO) outer sheath. Class E <sub>ca</sub> according to EN 50575*
<b>*Only European cables</b>	

**Table 2**

**Application Areas**

Perimeter: *Global*

Staff Function: -

Service Function: -

Business Line: *Infrastructure & Networks*

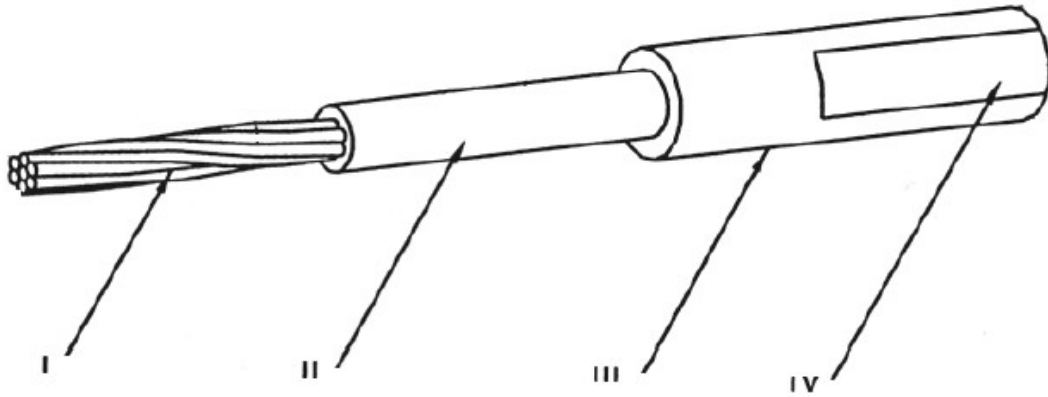

Figure 1 **Schematic drawing of Type I cables**

I – Al Conductor

II – Insulation

III – Outer Sheath

IV – Marking

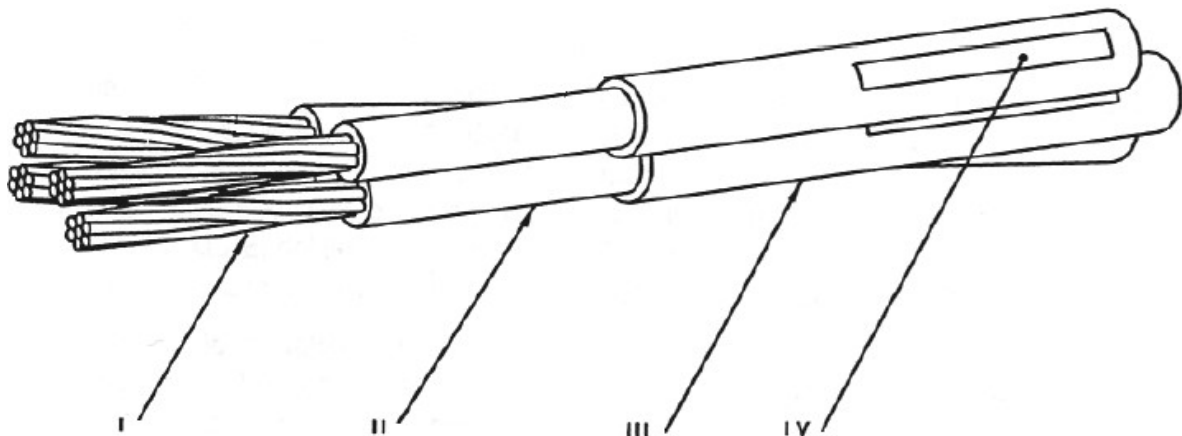

Figure 2 **Schematic drawing of Type II cable**

I – Conductor

II – Insulation

III – Outer Sheath

IV – Marking



**Application Areas**

Perimeter: *Global*

Staff Function: -

Service Function: -

Business Line: *Infrastructure & Networks*

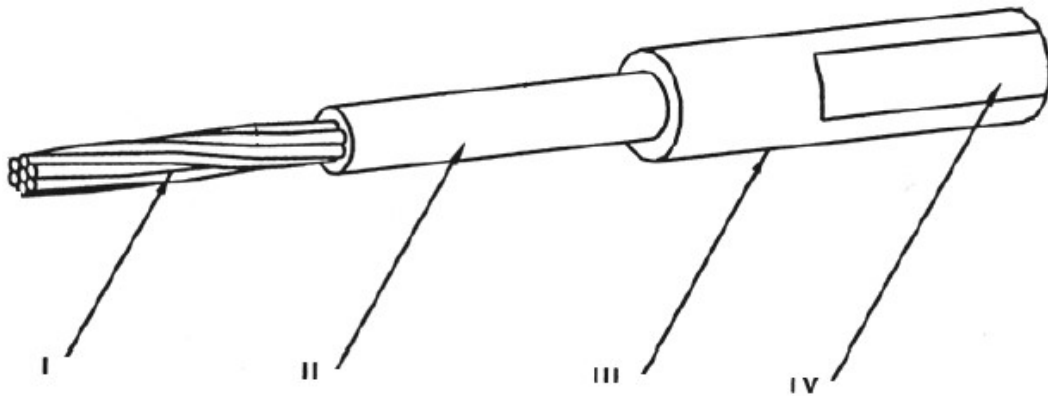

**Figure 3 Schematic drawing of Type III cable**

I – Cu Conductor

II – Insulation

III – Outer Sheath

IV – Marking

**Note: Figures are for illustrative purposes only.**

For each of these cable types, is defined as a sustainable equivalent :

- Cable whose outer sheath is made of polyolefin of vegetable origin;
- Cables with a percentage of recycled material (in the conductor and/or sheathing)

## 7.4 CONSTRUCTION CHARACTERISTICS

### 7.4.1.CONDUCTOR

For Type I and Type II cables the aluminum conductors shall be stranded compacted circular class 2, complying all the features specified herein and in standard IEC 60228. The conductor material shall be AA-1350 i.e. 99,5% aluminum content.

For Codensa cables the conductor material shall be AA-8000 series.

In Table 2 aluminum conductors main features are depicted.

**Application Areas**

Perimeter: *Global*

Staff Function: -

Service Function: -

Business Line: *Infrastructure & Networks*

Nominal cross-section [mm <sup>2</sup> ]	Minimum number of wires	Diameter of conductors		Maximum resistance of conductor at 20°C [Ω/km]
		[mm]		
		Minimum	Maximum	
10	6	3,6	4,2	3,08
16	6	4,6	5,2	1,91
25	6	5,6	6,5	1,2
35	6	6,6	7,5	0,868
50	6	7,7	8,6	0,641
95	15	11	12	0,32
150	15	13,7	15	0,206
240	30	17,6	19,2	0,125
400	53	22,3	24,6	0,0778

**Table 3** Aluminum conductors characteristics according to IEC 60228.

For Type III cables the copper conductors shall be stranded compacted circular class 2, complying all the features specified herein and in standard IEC 60228.

Copper purity shall not be less than 99,9 %.

In Table 2 copper conductors main features are depicted.

**Application Areas**

Perimeter: *Global*

Staff Function: -

Service Function: -

Business Line: *Infrastructure & Networks*

Nominal cross-section [mm <sup>2</sup> ]	Minimum number of wires	Diameter of conductors		Maximum resistance of conductor at 20°C [Ω/km]
		[mm]		
		Minimum	Maximum	
150	18	13,7	15	0,124
240	34	17,6	19,2	0,0754
400	53	22,3	24,6	0,047
630	53	28,7	32,5	0,0283

**Table 4 Copper conductors characteristics according to IEC 60228.**

The conductor material (Copper or Aluminum) shall contain minimum 10% of recycled material.

The conductor contained recycled material, shall be compliant with the characteristics required in this Global Standard.

**Application Areas**

 Perimeter: *Global*

Staff Function: -

Service Function: -

 Business Line: *Infrastructure & Networks*
**7.4.2.INSULATION**

The insulation shall be applied by a suitable extrusion process and shall form a compact and homogenous body. In addition, it shall be possible to remove without creating any damage to the conductor.

The insulating material shall be cross-linked polyethylene (XLPE) or high-performance polypropylene thermoplastic elastomer (HPTE) compliant with the characteristics required herein.

The XLPE or HPTE insulation must allow maximum conductor temperatures of 90 °C in normal operation and 250 °C under short circuit condition by at least 5 seconds.

The minimum thickness of insulation measured and accepted at any point of the cable shall not be less than 90% of the nominal value minus 0,1 mm. In addition, the average of all these measures should not be less than the nominal thickness.

$$t_{min} \geq 0,9 t_n - 0,1$$

Where:

$t_{min}$ : minimum insulation thickness in millimeters

$t_n$  : nominal thickness in millimeters

In Table 3 nominal and minimum thickness for XLPE and HPTE insulated cables are shown.:

Cross-section [mm <sup>2</sup> ]	Insulation nominal thickness [mm]	Insulation minimum thickness [mm]
10	0,7	0,53
16	0,7	0,53
25	0,9	0,71
35	0,9	0,71
50	1	0,80
95	1,1	0,89
150	1,4	1,16
240	1,7	1,43
400	2	1,7
630	2,4	2,06

**Table 5 Insulation thickness**

The cross-linked polyethylene insulation material shall be colorless (natural).

### 7.4.3. Outer Sheath

The outer sheath shall be resistant to moisture, abrasion and UV. In addition, it shall be free from heavy metals or volatile hydrocarbons.

The outer sheath material shall be polyolefin compliant with the characteristics required herein.

The outer sheath shall be adhered to the insulation.

The minimum thickness of the outer sheath measured and accepted at any point of the cable shall not be less than 85% of the nominal value minus 0,1 mm. In addition, the average of all these measures should not be less than the nominal thickness.

$$t_{min} \geq 0,85 t_n - 0,1$$

Where:

$t_{min}$ : minimum thickness in millimeters

$t_n$  : nominal thickness in millimeters

In Table 4 nominal and minimum thickness of the polyolefin outer sheath of Type I and Type II cables are shown.

Cross-section [mm <sup>2</sup> ]	Sheath nominal thickness [mm]	Sheath minimum thickness [mm]
10	1,3	1,01
16	1,3	1,01
25	1,3	1,01
35	1,3	1,01
50	1,3	1,01
95	1,4	1,09
150	1,4	1,09
240	1,5	1,18
400	1,9	1,5
630	2,2	1,77

**Table 6 PO outer sheath thickness**

Unless otherwise indicated in the local sections the outer sheath color shall be black.

ENEL could accept also outer sheath compound of vegetable origin and with recycled material (more than 30%).

Whether for the solution with PO of vegetable origin or recycled outer sheath, compound shall be compliant with the characteristics required in this Global Standard.

**Application Areas**Perimeter: *Global*

Staff Function: -

Service Function: -

Business Line: *Infrastructure & Networks*

---

## 7.5 CONSTRUCTIVE ASPECT

For Type II cables the cores shall be bundled in anticlockwise sense, with a pitch equal to  $(80 \pm 8)$  times the maximum value specified for diameter D of the phase cores.

## 7.6 AMPACITY AND SHORT-CIRCUIT RATING

See local section.

## 7.7 MARKING AND DESIGNATION OF THE CABLE

### 7.7.1. Cable designation

The cable designation shall be the following:

- Aluminum conductor: A
- Stranded compacted circular conductors: R
- Cross-linked polyethylene insulation: E4
- Polyolefin sheath: E
- Bundled assemble cores (if Type II): X
- Assigned voltage of the cable expressed in kV:  $U_0/U$
- Nominal cross-section of the conductor

### 7.7.2. Marking

The marking must be indelible, easily legible and carried out by engraving or in relief above the surface of the outer sheath in a continuous way.

The distance between the end of the mark and the beginning of the next identical mark does not exceed 550 mm.

For Endesa, see the local section.

The cable marking shall contain:

- Property name: ENEL
- Cable designation: see 7.7.1
- Reaction to fire class (Eca) (if applicable)
- Manufacturer name or trademark: XXXXX
- Identification of the production plant with a different letter of the alphabet: B
- Year and month of manufacturing (2022 12):

**Application Areas**Perimeter: *Global*

Staff Function: -

Service Function: -

Business Line: *Infrastructure & Networks*

- Metric marking It is put only on the core sheath of "PHASE 1" in the multipolar cables with visible helix. The inscription can be put on a cable surface other than that of the other inscriptions and it can also be made with ink.

- Core identification (FASE X) for Type II: to be placed on the sheath of each core. It shall be repeated at least every 100 mm in the intervals between two subsequent series of inscriptions. The inscription shall be repeated with a step no greater than 100mm on a cable surface other than that of the inscriptions.

Core identification could be made with ink.

For E-distribución, see the local section.

For Codensa, in marking include also Maximum operating temperature (**according RETIE**).

**Marking Example:**

- Type I cables (1x95 mm<sup>2</sup>)  
ENEL ARE4E-0,6/1 kV 50 Eca XXXX B 01 2017 12 0000
- Type II cables (3x95+50N)  
Phase 1 core  
ENEL ARE4EX-0,6/1 kV 95 Eca XXXX B 01 2017 12 0000 FASE 1... FASE 1  
Phase 2 or 3 core  
ENEL ARE4EX-0,6/1 kV 95 Eca XXXX B 01 2017 12 FASE X FASE X  
Neutral core  
ENEL ARE4EX-0,6/1 kV 50 Eca XXXX B 01 2017 12

For cables containing recycled material and cables containing polyolefin of vegetable origin, this information must be included in the marking at the end (Green PO, Recycled PO, RECYCLED AI...)

## 7.8 TESTING

### 7.8.1. Acceptance tests

Acceptance tests shall be carried out in the Supplier's facilities and are divided into two types with different sampling criteria, routine test and sample test.

#### 7.8.1.1 Routine tests

Routine tests shall be performed at 100% of delivered spools

The Routine tests are those indicated in par.7.8.5.1 - clause 1,2, 22.

#### 7.8.1.2 Sample test

Sample tests are carried out over samples taken from a complete cable (See **Table x** in sub-clause 7.8.1.3 for sampling).

**Application Areas**

Perimeter: *Global*

Staff Function: -

Service Function: -

Business Line: *Infrastructure & Networks*

The Sample tests are those indicated in par.7.8.5.1 - clause 3, 4, 6.

**7.8.2.Sampling and acceptance criteria**

Quantities always refer to the number of reels.

The supplier shall perform the sampling tests following a single sampling plan for normal inspection, AQL=1,5%, Level I in compliance with standard ISO 2859-1, as long as the resulting minimum number of samples (8) does not exceed 25% of the total lot size. In such case, the number of samples shall be 25% (1/4) of the total lot size rounded down to the nearest unit as shown in the following table.

Amount of Reels	Number of Samples	Acceptable Level	Rejection Level
1 - 32	Amount of reels /4*	0	1
33 - 280	8	0	1
281 - 1.200	32	1	2
1.201 - 3.200	50	2	3
3.201 - 10.000	80	3	4
10.001 - 35.000	125	5	6

**Table 7 Application of single sampling plan for normal inspection, AQL=1,5%, Level I in compliance with standard ISO 2859-1**

\*down to the nearest unit.

The costs of rejected materials will be charged to the bidder. The approval or rejection of each one of the samples will be according to what is required in standard ISO 2859-1 for each one of the trials. In detail, if a lot doesn't comply with what is required in the electric resistance test according to the approval requirements of the reference standard, the Inspector can carry out such test to all the units that make up the lot. If only a single spool is purchased, it must be tested according to what is indicated for a single sample.

Tests performed during the production process on semi-finished products may also be considered valid, as acceptance test, if:

- The tests are performed as required by the relevant technical specifications and technical standards;
- The sampling plans adopted by the Supplier are in compliance with the aforementioned ones;



**Application Areas**Perimeter: *Global*

Staff Function: -

Service Function: -

Business Line: *Infrastructure & Networks*

---

- The performed test results are properly recorded;
- The supplier demonstrates that the components/materials features do not vary during further production phases after the test.

The reports of the acceptance tests performed by the supplier shall be prepared and retained, for a possible verification by Enel inspectors.

### **7.8.3.Repetition of acceptance tests carried out in presence of Enel's inspector or designate**

The supplier shall be available to repeat the tests in the presence of Enel's inspector or designate, on a "reduced" sample of the supply lot

#### *7.8.3.1. Routine tests*

Routine tests must be performed on a reduced sample by applying the following reduction criteria:

The minimum between:

- 1/3 of Required Sampling (100%)
- Result of Single sampling plans for Normal Inspection, Level I, AQL 1% - according UNI ISO 2859-1 Ed 5-2007 (See **Table xx** in sub-clause 7.8.2.3 for sampling)

The Routine tests are those indicated in par.7.8.5.1 - clause 1,22 (spark test is not applicable).

#### *7.8.3.2. Sample tests*

Sample tests shall be performed at 1/2 of Required Simple size already adopted for the sample test independently performed by the supplier (referring to each test).

The Sample tests are those indicated in par.7.8.5.1 - clause 3, 4, 6

### **7.8.4.Sampling and acceptance criteria**

- Quantities always refer to the number of reels
- Enel inspector can choose to perform the test on spools already tested by the Supplier or on others from the lot)
- In case of repetition of routine test attended by Enel Inspector, the spark test is not applicable.

**Application Areas**

Perimeter: *Global*

Staff Function: -

Service Function: -

Business Line: *Infrastructure & Networks*

- If only a single spool is purchased, it shall be tested according to what is indicated for a single sample
- On a spool among those subjected to the electrical resistance measurement, shall be performed the verification of the total length of the cable, that shall be not shorter than that declared by the supplier by more than 0,5 m.

Amount of Reels	Number of Samples	Acceptable Level**	Rejection Level**
1 - 41	Amount of reels /3*	0	1
42 - 500	13	0	1
501 – 3200	50	1	2
3.201 – 10.000	80	2	3
10.001 - 35.000	125	3	4

**Table 8– Application of single sampling plan for normal inspection, AQL=1%, Level I in compliance with standard ISO 2859-1**

\*down to the nearest unit.

\*\*The negative result of a single test will result in the rejection of the lot or, when possible, in the repetition of the test on all the units, in order to accept only the compliant ones.

**7.8.5.Type test**

Type tests shall be performed before supplying a type of cable covered by this standard in order to demonstrate satisfactory performance characteristics to meet the intended application.

When type tests have been successfully performed on one type cable covered herein with a specific cross-section and construction characteristics, the type approval shall be accepted as valid for as long as the following conditions are met:

The conductor cross-section is not larger than that of the tested cable.

The cable as similar constructions as that of the tested cable, i.e utilizes same materials, (conductor, insulation, outer sheath) and the same manufacturing process.

When the design, materials or manufacturing process are changed (which might affect the performance characteristics of the cable), the relevant type tests shall be repeated.

Cables shall undergo type tests and acceptance tests for type approval

**Application Areas**

 Perimeter: *Global*

Staff Function: -

Service Function: -

 Business Line: *Infrastructure & Networks*

 7.8.5.1. *Tests list for Type I and Type II cables*

N°	Test	Requirements	Test Method	R	S	T
1	Conductor electrical resistance	See clause 5	IEC 60502-1 sub-clause 15.2	X	-	-
2	Spark test during manufacturing	No breakdown	IEC 62230	X	-	-
3	Conformity to the approved type	See clause 5	Constructional characteristics, markings colors, and phase identification shall be inspected by visual examination. Dimensions, thickness, pitches and diameters shall be measured according to IEC 60811 parts 201, 202 and 203.	-	X	-
4	Verification of the length declared by the supplier	On one of the cable sizes on which the conductor electrical resistances is verified, it must be checked, by measurement, that the finished cable length is not shorter than that declared by the Supplier by more than 0,5 m. In the case the verification result is negative, it must be continued on other sizes to execute a statistical control for attributes on sample as described in the ISO 2859/93 standard, adopting the simple sampling plan, ordinary inspection and acceptable quality level 2,5%, general inspection I		-	X	-
5	Insulation Mechanical properties* Before ageing on sample  Minimum tensile strength Minimum elongation at break	12,5 MPa 200%	IEC 60811-501	-	-	X
6	Insulation Hot set test *  Temperature Duration Mechanical stress Maximum elongation under load Maximum residual elongation	200 °C 15 min 0,2 MPa 175% 15%	IEC 60811-507	-	X	-
7	Insulation mechanical properties* After ageing on sample  Temperature Duration T1 <i>Minimum Tensile strength</i> Maximum variation T1/T0 <i>Minimum elongation at break</i> Maximum variation T1/T0	135 °C 168 h ±25% ±25%	IEC 60811-501 IEC 60811-401	-	-	X

**Application Areas**

 Perimeter: *Global*

Staff Function: -

Service Function: -

 Business Line: *Infrastructure & Networks*

N°	Test	Requirements	Test Method	R	S	T
8	Insulation resistance at 90 °C Volume resistivity [ $\Omega \cdot \text{cm}$ ] Insulation constant $K_i$ [ $M\Omega \cdot \text{km}$ ]	10 <sup>12</sup> 3,67	IEC 60502-1 sub-clause 17.2	-	-	X
9	Insulation Water absorption test* (Gravimetric method)  Temperature Duration Maximum variation of mass For density $\leq 1,02$ g/ml For density $> 1,02$ g/ml	85 °C 336 h  1 mg/cm <sup>2</sup> 5 mg/cm <sup>2</sup>	IEC 60811-402	-	-	X
10	Insulation Shrinkage test *  Duration Temperature Maximum shrinkage	1 h 130 °C 4%	IEC 60811-502	-	-	X
11	PO Mechanical properties Before ageing on sample  Minimum tensile strength Minimum elongation at break	12,5 MPa 300%	IEC 60811-501	-	-	X
12	PO mechanical properties After ageing on sample  Temperature Duration <i>Minimum Tensile strength</i> Maximum variation T1/T0 <i>Minimum elongation at break</i> Maximum variation T1/T0	110 $\pm$ 2 °C 168 h  $\pm$ 25% $\pm$ 25%	IEC 60811-501 IEC 60811-401	-	-	X
13	PO pressure test at high temperature  Duration Temperature Coefficient k Maximum depth of indentation	6 h 105 $\pm$ 2 °C 0,6/0,7 50%	IEC 60811-508	-	-	X
14	PO tear resistance test  Temperature Minimum resistance	20 $\pm$ 5 °C 9 N/mm	HD 605 Sub clause 2.2.2.2	-	-	X

**Application Areas**

 Perimeter: *Global*

Staff Function: -

Service Function: -

 Business Line: *Infrastructure & Networks*

N°	Test	Requirements	Test Method	R	S	T
15	PO test at low temperature When cable $D > 12,5$ mm  Elongation test Temperature Minimum elongation When cable $D \leq 12,5$ mm Bending test Temperature	  $-15 \pm 2^\circ\text{C}$ 20%  $-15 \pm 2^\circ\text{C}$	  IEC 60811-505  IEC 60811-504	-	-	X
16	PO loss of mass test  Temperature Duration Maximum loss of mass	  $100 \pm 2^\circ\text{C}$ 168 h $0,5 \text{ mg/cm}^2$	  IEC 60811-409	-	-	X
17	PO Water absorption test (Gravimetric method)  Temperature Duration Maximum variation of mass	  $85 \pm 2^\circ\text{C}$ 336 h $5 \text{ mg/cm}^2$	  IEC 60811-402	-	-	X
18	PO Heavy metals content test Lead	 $< 0,5\%$	 Spectrophotometer	-	-	X
19	PO UV ray resistance test  Tensile strength max variation  Elongation at break max variation  Decoloration	  15%  15%  Low	  HD 605 Sub clause 2.4.23 UNE 211605 for Endesa See Local section B for conditions	-	-	X
20	PO halogen acid gas content	$\leq 5 \text{ mg/g}$	IEC 60754-1	-	-	X
21	PO gas acidity and conductivity  Minimum pH Maximum conductivity	  4.3 $10 \mu\text{S/mm}$ ,	  IEC 60754-2	-	-	X

**Application Areas**

 Perimeter: *Global*

Staff Function: -

Service Function: -

 Business Line: *Infrastructure & Networks*

N°	Test	Requirements	Test Method	R	S	T
22	Voltage Test (Manufacturing length)					
	Test voltage	3,5 kV AC or 8,5 kV DC	IEC 60502-1 sub-clause 15.3.2	x	-	-
	Test duration	5 min				
	Test Result	No breakdown				
23	Voltage Test for 4 h (Complete cable)					
	Test voltage	2,4 kV	IEC 60502-1 sub-clause 17.3	-	-	X
	Test duration	4 h				
	Test Result	No breakdown				
24	Cold impact test (Complete cable)					
	Temperature	-15±2 °C	IEC 60811-506	-	-	X
	Test Result	No cracks				
25	Non contamination test (Complete cable)					
	PO Mechanical properties		IEC 60811-501 IEC 60811-401	-	-	X
	Temperature	110±2 °C				
	Duration T1	168 h				
<i>Minimum elongation at break</i>						
	Maximum variation T1/T0	±25%				
26	Shrinkage test (Complete cable)					
	L	200 mm	IEC 60811-503	-	-	X
	Duration	5 x 5 h				
	Temperature	80±2 °C				
	Maximum shrinkage	4%				
27	Special bending test (Complete cable)	No breakdown	HD 605 2.4.1.2	-	-	X
28	Abrasion resistance test (Complete cable)					
	Temperature	20±5 °C	HD 605 Sub-clause 2.4.22	-	-	X
	Mass (cross-section ≤120 mm <sup>2</sup> )	12 kg				
	Mass (cross-section ≥150 mm <sup>2</sup> )	18 kg				
	Speed	0,3±15% m/s				
	Number of scratches	8				
29	Reaction to fire test (Complete cable)	E <sub>ca</sub>	EN 50575 IEC 60332-1-2	-	-	X

**Application Areas**

 Perimeter: *Global*

Staff Function: -

Service Function: -

 Business Line: *Infrastructure & Networks*

N°	Test	Requirements	Test Method	R	S	T
30	Measurement of smoke density (Complete cable) Minimum light transmittance	60%	IEC 61034-2	-	-	X
*For HPTE insulation applicability and reference values are given in standard CEI 20-86 (As CEI 20-86 refers to MV cable, ENEL reserves the right to evaluate different tests)						
R: Routine test S: Sample test T: Type test						

## 7.9 TECHNICAL CONFORMITY ASSESSMENT

### 7.9.1 General conditions

The manufacturer shall provide personnel and equipment necessary to carry out type tests and acceptance tests described herein. Otherwise, the supplier could hire the service to a laboratory previously accepted by the customer and assume the cost. The product shall comply with the requirements of GSCG002 regarding the Technical Conformity Assessment.

The equipment should be properly calibrated by a laboratory certified or approved by the client. The manufacturer shall possess up to date calibration certificates (to turn over) at the time of inspection.

### 7.9.2 Acknowledgement of TCA for previous revision of the standard.

Products with TCA in force under the ENEL Global standard GSCC002 Rev 5 of 11/2018 and their respective addendums will be recognized as homologated material for the present technical specification.

Enel, therefore, reserves the right to check that the conditions of supply, the type codes, the country codes etc. shall comply with the requirements of this technical specification.

The type A Doc. must contain the list of material informing the material origin and the percentage of recycled material.

**Application Areas**

 Perimeter: *Global*

Staff Function: -

Service Function: -

 Business Line: *Infrastructure & Networks*

## 8. LOCAL SECTION

LOCAL SECTION A - e-distribuzione (Italy) and e-distributie (Romania)

ITEM	TITLE	DESCRIPTION														
<b>Errore</b> . <b>L'origine riferimento non è stata trovata.</b>	Local Standards	e-distribuzione (Italy), e-distributie (Romania) <ul style="list-style-type: none"> <li>Standard PVR 006 Operational Note Vendor Rating Control: BARCODES Warranty and Traceability of Enel Distribution Materials.</li> <li>GUI 102/GUI 102 RO "Bobine per il trasporto di cavi elettrici, cavi ottici e conduttori per le linee elettriche di media e bassa tensione"</li> </ul>														
5.5	Ampacity and short-circuit rating	e-distribuzione (Italy), e-distributie (Romania) <b>Ampacity</b> The ampacity estimated values shall be given for network design purposes. Such currents shall be calculated in steady state condition, for single core laying and four-core visible helix laying, when installed in open air, directly buried and buried in duct using the following operational conditions: <ul style="list-style-type: none"> <li>Maximum conductor temperature 90 °C</li> <li>Ambient air temperature 40 °C</li> <li>Ground temperature 20 °C</li> <li>Depth of laying 0,8 m</li> <li>Soil thermal resistivity 1,5 K m/W</li> </ul> <b>Short-circuit rating</b> The following estimated values could be used as reference <table border="1" data-bbox="571 1518 1445 1832"> <thead> <tr> <th>Cross-section [mm<sup>2</sup>]</th> <th>Short circuit rating [kA]</th> </tr> </thead> <tbody> <tr> <td>10</td> <td>0,95</td> </tr> <tr> <td>25</td> <td>2,3</td> </tr> <tr> <td>50</td> <td>4,7</td> </tr> <tr> <td>95</td> <td>8,9</td> </tr> <tr> <td>150</td> <td>14,1</td> </tr> <tr> <td>240</td> <td>22,7</td> </tr> </tbody> </table> The short circuit capacities are determined using the following parameters: Conductor initial temperature: 90 °C Conductor final temperature: 250 °C Short-circuit duration: 1 s	Cross-section [mm <sup>2</sup> ]	Short circuit rating [kA]	10	0,95	25	2,3	50	4,7	95	8,9	150	14,1	240	22,7
Cross-section [mm <sup>2</sup> ]	Short circuit rating [kA]															
10	0,95															
25	2,3															
50	4,7															
95	8,9															
150	14,1															
240	22,7															



**Application Areas**

 Perimeter: *Global*

Staff Function: -

Service Function: -

 Business Line: *Infrastructure & Networks*

## LOCAL SECTION A - e-distribuzione (Italy) and e-distributie (Romania)

ITEM	TITLE	DESCRIPTION																														
8	CONDITIONS OF SUPPLY	<p>e-distribuzione (Italy), e-distributie (Romania)</p> <p>The maximum length and reel type for each configuration of cable are depicted in the following table:</p> <table border="1"> <thead> <tr> <th>Formation [n° x mm<sup>2</sup>]</th> <th>Maximum Length [m]</th> <th>Coil Type (GUI 102)</th> </tr> </thead> <tbody> <tr> <td>1x10</td> <td>1000</td> <td>06</td> </tr> <tr> <td>1x25</td> <td>1000</td> <td>08</td> </tr> <tr> <td>1x50</td> <td>1000</td> <td>08</td> </tr> <tr> <td>1x95</td> <td>500</td> <td>10</td> </tr> <tr> <td>1x150</td> <td>500</td> <td>12</td> </tr> <tr> <td>1x240</td> <td>500</td> <td>12</td> </tr> <tr> <td>3x95+50N</td> <td>500</td> <td>18</td> </tr> <tr> <td>3x150+95N</td> <td>500</td> <td>20</td> </tr> <tr> <td>3x240+150N</td> <td>500</td> <td>22</td> </tr> </tbody> </table> <p>The admitted tolerance is equal to <math>\pm 3\%</math> of the length indicated in the order. Coils with total length less than indicated in the table above are permitted, as long as such reels constitute up a maximum to 10% of the cables forming the deliver batch (same transport document).</p> <p>However, each coil shall contain at least 100 m, excluding the sample sizes whose length was reduced during the acceptance test.</p> <p>The far end of the cables shall be protected against the moisture.</p> <p>Due to traceability in the network a bar code shall be applied on the drum.</p> <p>The far end of the cables shall be protected against the moisture.</p> <p>Due to traceability in the network a bar code shall be applied on the drum.</p> <p>Such bar code shall be in compliance with technical specification PVR006.</p> <p>Reels shall be made in compliance with the standard GUI102/GUI 102 RO.</p>	Formation [n° x mm <sup>2</sup> ]	Maximum Length [m]	Coil Type (GUI 102)	1x10	1000	06	1x25	1000	08	1x50	1000	08	1x95	500	10	1x150	500	12	1x240	500	12	3x95+50N	500	18	3x150+95N	500	20	3x240+150N	500	22
Formation [n° x mm <sup>2</sup> ]	Maximum Length [m]	Coil Type (GUI 102)																														
1x10	1000	06																														
1x25	1000	08																														
1x50	1000	08																														
1x95	500	10																														
1x150	500	12																														
1x240	500	12																														
3x95+50N	500	18																														
3x150+95N	500	20																														
3x240+150N	500	22																														

**Application Areas**



 Perimeter: *Global*

Staff Function: -

Service Function: -

 Business Line: *Infrastructure & Networks*

## LOCAL SECTION A - e-distribuzione (Italy) and e-distributie (Romania)

ITEM	TITLE	DESCRIPTION						
8	CONDITIONS OF SUPPLY	<p>Following standard EN 50575, the CE marking and labelling shall be in accordance with the general principles set out in Article 30 of regulation (EC) No. 765/2008 and shall be affixed visibly, legibly and indelibly to the product labels affixed to the reels, coils or drums.</p> <p>The CE markings shall be followed by:</p> <ul style="list-style-type: none"> <li>• The last two digits of the year in which it was first affixed</li> <li>• The name and the registered address of the manufacturer, or the identifying mark allowing identification of the name and address of the manufacturer easily and without ambiguity.</li> <li>• The unique identification code of the product-type</li> <li>• The reference number of the declaration of performance</li> <li>• The class of the performance declared</li> <li>• The date reference to the harmonized technical specification applied</li> <li>• The identification number of the notified body</li> <li>• The intended use as laid down in the applied harmonized technical specification.</li> </ul> <p>CE marking example for products subject to AVCP system 3.</p> <table border="1" data-bbox="587 1489 1142 2004"> <tr> <td data-bbox="587 1489 871 1610">             XXXX         </td> <td data-bbox="871 1489 1142 1610"> <i>CE marking, consisting of the "CE"-symbol</i>   <i>Identification number of the notified test laboratory</i> </td> </tr> <tr> <td data-bbox="587 1610 871 1744">           AnyCo Ltd, PO Box 21, B-1050, Brussels, Belgium             14             (To be given by the manufacturer)         </td> <td data-bbox="871 1610 1142 1744"> <i>Name and the registered address of the manufacturer, or identifying mark</i>   <i>Last two digits of the year in which the marking was first affixed</i>   <i>Reference number of the DoP</i> </td> </tr> <tr> <td data-bbox="587 1744 871 2004">           EN 50575:2014             (To be given by the manufacturer)             Supply of electricity in buildings and other civil engineering works with the objective of limiting the generation and spread of fire and smoke             Reaction to Fire: E             Dangerous substances: none         </td> <td data-bbox="871 1744 1142 2004"> <i>No. of European Standard applied, as referenced in OJEU</i>   <i>Unique identification code of the product-type</i>   <i>Intended use of the product as laid down in the European Standard applied</i>   <i>Class of performance</i> </td> </tr> </table>	 XXXX	<i>CE marking, consisting of the "CE"-symbol</i>  <i>Identification number of the notified test laboratory</i>	AnyCo Ltd, PO Box 21, B-1050, Brussels, Belgium  14  (To be given by the manufacturer)	<i>Name and the registered address of the manufacturer, or identifying mark</i>  <i>Last two digits of the year in which the marking was first affixed</i>  <i>Reference number of the DoP</i>	EN 50575:2014  (To be given by the manufacturer)  Supply of electricity in buildings and other civil engineering works with the objective of limiting the generation and spread of fire and smoke  Reaction to Fire: E  Dangerous substances: none	<i>No. of European Standard applied, as referenced in OJEU</i>  <i>Unique identification code of the product-type</i>  <i>Intended use of the product as laid down in the European Standard applied</i>  <i>Class of performance</i>
 XXXX	<i>CE marking, consisting of the "CE"-symbol</i>  <i>Identification number of the notified test laboratory</i>							
AnyCo Ltd, PO Box 21, B-1050, Brussels, Belgium  14  (To be given by the manufacturer)	<i>Name and the registered address of the manufacturer, or identifying mark</i>  <i>Last two digits of the year in which the marking was first affixed</i>  <i>Reference number of the DoP</i>							
EN 50575:2014  (To be given by the manufacturer)  Supply of electricity in buildings and other civil engineering works with the objective of limiting the generation and spread of fire and smoke  Reaction to Fire: E  Dangerous substances: none	<i>No. of European Standard applied, as referenced in OJEU</i>  <i>Unique identification code of the product-type</i>  <i>Intended use of the product as laid down in the European Standard applied</i>  <i>Class of performance</i>							

**Technical Specification code: GRI-GRI-MAT-E&C-0007**

Version no. 6 dated 10/2022

**Subject:** Global Infrastructure and Networks - GSC002 LOW VOLTAGE UNDERGROUND CABLES WITH RATED VOLTAGE  $U_0/U(U_m)$  0,6/1,0(1,2) kV.

**Application Areas**

Perimeter: *Global*

Staff Function: -

Service Function: -

Business Line: *Infrastructure & Networks*

ITEM	TITLE	DESCRIPTION
	CONDITIONS OF SUPPLY	In compliance with standard EN 50575 in particular annex V of the EU Construction Products Regulation n° 305/2011 (CPR) the supplier shall elaborate a Declaration of performance (DoP) and shall dispose a CE marking in function of the assessment and verification of constancy of performance (AVCP).

**Application Areas**

 Perimeter: *Global*

Staff Function: -

Service Function: -

 Business Line: *Infrastructure & Networks*

## LOCAL SECTION B - ENDESA DISTRIBUCIÓN ELÉCTRICA (Spain)

ITEM	TITLE	DESCRIPTION
3.3	Local standards	<p><u>Endesa Distribución Eléctrica (Spain)</u></p> <p>a) UNE-HD 603-5X: 2007/1M "Distribution cables of rated voltage 0,6/1 kV. Par 5: XLPE insulated cables - Unarmored. Section X: Cables without concentric conductor and polyolefine compound sheath (types 5X-1 and 5X-2)</p> <p>b) UNE 211435 "Guía para la elección de cables eléctricos de tensión asignada superior o igual a 0,6/1 kV para circuitos de distribución"</p> <p>c) UNE 211605 "Ensayo de envejecimiento climático de materiales de revestimiento de cables "</p> <p>d) UNE 21167 "Bobinas de madera para cables aislados de transporte y distribución. Características generales"</p>
5.2	Insulation	The depicted material in this document can comply DIX 3 from standard HD 603 S1
5.3	Outer Sheath.	The depicted material herein can comply DMO1 from standard HD 603 S1

**Application Areas**

Perimeter: *Global*

Staff Function: -

Service Function: -

Business Line: *Infrastructure & Networks*

LOCAL SECTION B - ENDESA DISTRIBUCIÓN ELÉCTRICA (Spain)

ITEM	TITLE	DESCRIPTION
5.5	Ampacity and Short-circuit rating	<p>Endesa Distribución Eléctrica (Spain)</p> <p>For all uses of cables, the maximum current-carrying permitted for conductors must be in accordance with Low-Voltage Electrotechnical Regulations (REBT), approved by R.D. 842/2002, of 2 August and Standard UNE 211435.</p> <p>The ampacity estimated values shall be given for network design purposes. Such currents shall be calculated in steady state condition, for a three-phase circuit (3 phases + neutral) far from any heat source using the following conditions:</p> <ul style="list-style-type: none"> <li>• Maximum conductor temperature 90 °C</li> <li>• Ambient air temperature 40 °C</li> <li>• Ground temperature 25 °C</li> <li>• Depth of laying 0,7 m</li> <li>• Soil thermal resistivity 1,5 K m/W</li> </ul> <p>For short-circuit rating the following condition shall be used:</p> <ul style="list-style-type: none"> <li>• Initial conductor temperature 90 °C</li> <li>• Final conductor temperature 250 °C</li> </ul>

**Application Areas**

Perimeter: *Global*

Staff Function: -

Service Function: -

Business Line: *Infrastructure & Networks*

ITEM	TITLE	DESCRIPTION
5.6.1	Cable designation	<p>Endesa Distribución Eléctrica (Spain)</p> <p>The cable designation must content:</p> <p>Structural cable characteristics</p> <p>Insulation: <b>X</b> (cross-linked polyethylene)</p> <p>Sheath: <b>Z1</b> (polyolefin)</p> <p>Type 5X.1 S</p> <p>Assigned voltage of the cable expressed in kV: values <b>U<sub>0</sub></b> and <b>U: 0,6/1 kV</b></p> <p>Information regarding the conductor: The digit 1, corresponding to only one conductor, followed by the x sign, the nominal cross-section of the conductor expressed in sq. mm and the letter Al that indicates conductor in aluminum is used.</p> <p>Example of cable designation for Endesa:</p> <p><b>XZ1 (S) 0.6/1 kV 1x150 Al</b></p> <p>0,6/1 kV unipolar cable with 150 mm<sup>2</sup> stranded compacted aluminum conductor, insulated with cross-linked polyethylene and outer sheath made of polyolefin</p>

**Application Areas**

 Perimeter: *Global*

Staff Function: -

Service Function: -

 Business Line: *Infrastructure & Networks*

## LOCAL SECTION B - ENDESA DISTRIBUCIÓN ELÉCTRICA (Spain)

ITEM	TITLE	DESCRIPTION
5.6.2	Marking	<p>Endesa Distribución Eléctrica (Spain)</p> <p>The cable marking must content:</p> <ul style="list-style-type: none"> <li>• Name of the manufacturer</li> <li>• Complete cable designation</li> <li>• Reaction to fire class according to UNE 50575</li> <li>• Last two digits of the year of production</li> <li>• Marking each meter</li> <li>• Additional markings such as traceability codes, certifies, etc.</li> </ul> <p>The separation between the markings must not be greater than 300 mm</p> <p>Example of cable marking manufactured in 2017: (Name of the supplier) XZ1 (S) 0,6/1 KV 1x150 AL Eca 17 (Additional markings)</p>
6.3	Tests list for Type I and Type II cableS	<p><u>PO UV RAY RESISTANCE TEST condition shall be the following:</u></p> <ul style="list-style-type: none"> <li>• Samples: Of the outer sheath</li> <li>• Radiation: 43 W/m<sup>2</sup></li> <li>• N° of cycles: 1</li> <li>• Chamber temperatura between phase 3 and 4 of the cycle: 55 °C</li> </ul> <p>Black body máximo temperature: 70°C.</p>

## LOCAL SECTION B - ENDESA DISTRIBUCIÓN ELÉCTRICA (Spain)

ITEM	TITLE	DESCRIPTION
8	CONDITIONS OF SUPPLY	<p>The admitted tolerance for a samples is equal to <math>\pm 3\%</math> of the length indicated in the order; shorter lengths are admitted up to a maximum of 10% of the cables forming the delivery lot (same transport document), provided that each one is at least 100 m; in calculating the aforesaid 10%, the sample sizes whose length is reduced due to the acceptance tests are excluded.</p> <p>Reels shall be in compliance with the Standard UNE 21167 "Bobinas de Madera para cables aislados de transporte y distribucion"</p> <p>1) Technical report (TR)</p> <p>The technical report (TR) must consist of the documents described below.</p> <p>It is specified that some requirements in the following paragraphs are preceded by the word "Prescription", and others by the word "Indication".</p> <p>In the first case the requirements are normative, therefore satisfying them is a necessary (but not sufficient) condition for acceptance during the trial period. In the second case, however, the content of the required information is not binding for acceptance during the trial period.</p> <p>2) Technical document.</p> <p>Technical working drawing of the coil, including representation of the two sections (longitudinal and transversal) completed with all the dimensional measurements and with the points where the drum is anchored to the flanges highlighted (enlarged diagram of the part).</p> <p>The following dimensional characteristics must be provided:</p> <p>Parts in wood:</p>



**Application Areas**

 Perimeter: *Global*

Staff Function: -

Service Function: -

 Business Line: *Infrastructure & Networks*

## LOCAL SECTION B - ENDESA DISTRIBUCIÓN ELÉCTRICA (Spain)

ITEM	TITLE	DESCRIPTION								
8	CONDITIONS OF SUPPLY	<table border="1" data-bbox="737 667 1300 1205"> <tr> <td data-bbox="737 667 986 869">For the flange</td> <td data-bbox="986 667 1300 869">Board width Diameter Thickness Diameter of axial hole Counter-flange thickness</td> </tr> <tr> <td data-bbox="737 869 986 922">Coil width</td> <td data-bbox="986 869 1300 922"></td> </tr> <tr> <td data-bbox="737 922 986 1086">For the Drum</td> <td data-bbox="986 922 1300 1086">Board width diameter width Staves thickness</td> </tr> <tr> <td data-bbox="737 1086 986 1205">For the tie rods</td> <td data-bbox="986 1086 1300 1205">Number diameter Length</td> </tr> </table> <p data-bbox="571 1209 705 1240">Metal parts</p> <p data-bbox="571 1263 1471 1339">Dimensional and number of metal components (tie rods, support and fixing plates)</p> <p data-bbox="571 1361 1018 1393">3) Photographic documentation.</p> <p data-bbox="571 1415 1136 1447">The following documentation shall be delivered:</p> <ul data-bbox="571 1469 1471 1706" style="list-style-type: none"> <li data-bbox="571 1469 1471 1545">• A side view and a front view photo (for a total of at least 6 photos) showing:           <ul data-bbox="571 1568 1168 1706" style="list-style-type: none"> <li data-bbox="571 1568 769 1599">-The empty coil;</li> <li data-bbox="571 1621 1168 1653">-The coil with wound cable without external cover;</li> <li data-bbox="571 1675 1024 1706">-The coil complete with external cover</li> </ul> </li> <li data-bbox="571 1729 1471 1854">• The detailed view of the identification plate where the coil and supply data are provided (at an enlargement level such as to allow the information photographed to be read).</li> </ul> <p data-bbox="571 1930 1072 1962">4) Technical data sheet of the wood.</p> <p data-bbox="571 1984 730 2016">Prescriptions</p>	For the flange	Board width Diameter Thickness Diameter of axial hole Counter-flange thickness	Coil width		For the Drum	Board width diameter width Staves thickness	For the tie rods	Number diameter Length
For the flange	Board width Diameter Thickness Diameter of axial hole Counter-flange thickness									
Coil width										
For the Drum	Board width diameter width Staves thickness									
For the tie rods	Number diameter Length									

**Application Areas**

Perimeter: *Global*

Staff Function: -

Service Function: -

Business Line: *Infrastructure & Networks*

LOCAL SECTION B - ENDESA DISTRIBUCIÓN ELÉCTRICA (Spain)

ITEM	TITLE	DESCRIPTION
8	CONDITIONS OF SUPPLY	<p>Wood species coming from conifers or other wood of documented equivalent performance characteristics must be used. The wood used must be free of fungi and insects; the boards must be without non-adherent (dead) chamfers and knobs</p> <p>Instructions:</p> <p>The percentage of maximum humidity of the wood at the end of the coil fabrication process shall be stated.</p> <p>The description of any treatments that the wood undergoes shall be provided.</p> <p>5) Technical data sheet of the metals.</p> <p>Instructions:</p> <p>The type of material used shall be stated.</p> <p>6) Construction methods.</p> <p>Prescriptions:</p> <p>The coil must not, in any case, have metallic projections of any kind (they could in fact cause cuts or injuries during handling). Any wooden parts must not be painted.</p> <p>The outer surface of the drum and that inside the flange must be planed and the boards forming the flanges must be put close to each other; the nailing of the boards for the flanges must be riveted on the outside and the nail head must penetrate inside the boards by riveting.</p> <p>The boards of the drum must have chamfered edges and be put close to each other; uneven boards or steps between two boards or between boards and metal tie rods are not allowed.</p> <p>Instructions:</p> <p>Specify the welding type/technique (if present) and the anti-oxidation treatments.</p> <p>7) Protections</p>

**Application Areas**

 Perimeter: *Global*

Staff Function: -

Service Function: -

 Business Line: *Infrastructure & Networks*

## LOCAL SECTION B - ENDESA DISTRIBUCIÓN ELÉCTRICA (Spain)

ITEM	TITLE	DESCRIPTION
8	CONDITIONS OF SUPPLY	<p>The cables must be protected in such a way as to prevent damage or tampering during transport and handling, also within the sphere of ENDESA.</p> <p>If the bidder plans to use a type of protection as an alternative to staves, it must not be made with materials that during disposal are classifiable as hazardous waste; in any case, all protections that are alternatives to staves must be explicitly approved by ENDESA during homologation or during the tender process.</p> <p>The free ends of the cable must be properly protected against the penetration of water and moisture during transport, storage (which may also be outdoors) and lying.</p> <p>The finished and inspected cable coils at the Constructor's facilities cannot be parked without staves or equivalent protections in zones exposed to bad weather (sun, rain, etc.) and to accidental impacts unless for the time necessary for their staving or similar protection.</p> <p>Unless otherwise provided in the purchase order letter, the protection (staving or other) of the coils must be executed 100%.</p> <p>The spacing between the external layer of the cable and the staving must be sufficient for preventing damage to the cable and in any case never less than 50 mm; to comply with said prescription, sizes of length reduced up to the minimum allowed can be preferred, if necessary.</p> <p>8) Labeling.</p> <p>At least the following data shall be shown in addition to what is required in the order on the external surface of at least one of the flanges of the transport coil, or on the packaging of every single skein, with clearly legible and indelible characters, if applicable:</p> <ul style="list-style-type: none"> <li>• The ENDESA code of the cable;</li> <li>• The name or trademark of the company that owns the coil;</li> <li>• The name of the Constructor of the cable;</li> <li>• The code and formation of the cable;</li> <li>• The type and code of the coil;</li> </ul>

**Application Areas**

 Perimeter: *Global*

Staff Function: -

Service Function: -

 Business Line: *Infrastructure & Networks*

## LOCAL SECTION B - ENDESA DISTRIBUCIÓN ELÉCTRICA (Spain)

ITEM	TITLE	DESCRIPTION
8	CONDITIONS OF SUPPLY	<ul style="list-style-type: none"> <li>• The total gross weight (only for the sizes on coil)</li> <li>• The net weight;</li> <li>• The weight of one meter of cable;</li> <li>• The actual length of the size;</li> <li>• The details of the ENDESA order;</li> <li>• The number and date of notice of shipment or, for the skeins, the number of the production lot (job no.).</li> </ul> <p><b>Note: The two external faces of the flanges for coils made of wood and the two opposing faces of the pallets, which can be used for shipping several types of cable, must bear the mark demonstrating that the wood used for their construction has been treated as required in directive 2000/29/EC, referred to in SECTION 8.2 7.2.</b></p> <p>Following standard EN 50575, the CE marking and labelling shall be in accordance with the general principles set out in Article 30 of regulation (EC) No. 765/2008 and shall be affixed visibly, legibly and indelibly to the product labels affixed to the reels, coils or drums.</p> <p>The CE markings shall be followed by:</p> <ul style="list-style-type: none"> <li>• The last two digits of the year in which it was first affixed</li> <li>• The name and the registered address of the manufacturer, or the identifying mark allowing identification of the name and address of the manufacturer easily and without ambiguity.</li> <li>• The unique identification code of the product-type</li> <li>• The reference number of the declaration of performance</li> <li>• The class of the performance declared</li> <li>• The date reference to the harmonized technical specification applied</li> <li>• The identification number of the notified body</li> <li>• The intended use as laid down in the applied harmonized technical specification.</li> </ul> <p>E marking example for products subject to AVCP system 3.</p>

**Application Areas**



 Perimeter: *Global*

Staff Function: -

Service Function: -

 Business Line: *Infrastructure & Networks*

## LOCAL SECTION B - ENDESA DISTRIBUCIÓN ELÉCTRICA (Spain)

ITEM	TITLE	DESCRIPTION										
8	CONDITIONS OF SUPPLY	<table border="1" style="width: 100%; border-collapse: collapse;"> <tr> <td style="text-align: center; width: 50%; padding: 5px;">             XXXX         </td> <td style="width: 50%; padding: 5px;"> <i>Marcado CE, consistente en el símbolo "CE"</i> </td> </tr> <tr> <td style="text-align: center; padding: 5px;">           AnyCo Ltd, PO Box 21, B-1050, Brussels, Belgium         </td> <td style="padding: 5px;"> <i>Número de identificación del laboratorio notificado de ensayos</i> </td> </tr> <tr> <td style="text-align: center; padding: 5px;">           14             (A indicar por el fabricante)         </td> <td style="padding: 5px;"> <i>Nombre y dirección registrada del fabricante, o marca identificativa</i>   <i>Los dos últimos dígitos del año en que se fijó el marcado por primera vez</i> </td> </tr> <tr> <td style="text-align: center; padding: 5px;">           EN 50575:2014             (A indicar por el fabricante)         </td> <td style="padding: 5px;"> <i>Número de referencia de la Declaración de Prestaciones (DoP)</i>   <i>Código de la norma europea de aplicación, como se cite en el DOUE</i> </td> </tr> <tr> <td style="padding: 5px;">           Suministro de electricidad en edificios y en otras obras de ingeniería civil con el objetivo de limitar la generación y propagación de fuego y humo             Reacción al fuego: E<sub>ca</sub>             Sustancias peligrosas: Ninguna         </td> <td style="padding: 5px;"> <i>Código de identificación único del producto tipo</i>   <i>Uso previsto del producto como se indica en la norma europea aplicada</i>   <i>Clase de prestaciones</i> </td> </tr> </table> <p>9) Transport</p> <p>In order to facilitate unloading, drums should be arranged in the vehicle with a distance between the covers for inputting the charging and discharging means, so that either can be discharged with handling means with forks.</p> <p>In compliance with standard EN 50575 in particular annex V of the EU Construction Products Regulation n° 305/2011 (CPR) the supplier shall elaborate a Declaration of performance (DoP) and shall dispose a CE marking in function of the assessment and verification of constancy of performance (AVCP).</p>	 XXXX	<i>Marcado CE, consistente en el símbolo "CE"</i>	AnyCo Ltd, PO Box 21, B-1050, Brussels, Belgium	<i>Número de identificación del laboratorio notificado de ensayos</i>	14  (A indicar por el fabricante)	<i>Nombre y dirección registrada del fabricante, o marca identificativa</i>  <i>Los dos últimos dígitos del año en que se fijó el marcado por primera vez</i>	EN 50575:2014  (A indicar por el fabricante)	<i>Número de referencia de la Declaración de Prestaciones (DoP)</i>  <i>Código de la norma europea de aplicación, como se cite en el DOUE</i>	Suministro de electricidad en edificios y en otras obras de ingeniería civil con el objetivo de limitar la generación y propagación de fuego y humo  Reacción al fuego: E <sub>ca</sub>  Sustancias peligrosas: Ninguna	<i>Código de identificación único del producto tipo</i>  <i>Uso previsto del producto como se indica en la norma europea aplicada</i>  <i>Clase de prestaciones</i>
 XXXX	<i>Marcado CE, consistente en el símbolo "CE"</i>											
AnyCo Ltd, PO Box 21, B-1050, Brussels, Belgium	<i>Número de identificación del laboratorio notificado de ensayos</i>											
14  (A indicar por el fabricante)	<i>Nombre y dirección registrada del fabricante, o marca identificativa</i>  <i>Los dos últimos dígitos del año en que se fijó el marcado por primera vez</i>											
EN 50575:2014  (A indicar por el fabricante)	<i>Número de referencia de la Declaración de Prestaciones (DoP)</i>  <i>Código de la norma europea de aplicación, como se cite en el DOUE</i>											
Suministro de electricidad en edificios y en otras obras de ingeniería civil con el objetivo de limitar la generación y propagación de fuego y humo  Reacción al fuego: E <sub>ca</sub>  Sustancias peligrosas: Ninguna	<i>Código de identificación único del producto tipo</i>  <i>Uso previsto del producto como se indica en la norma europea aplicada</i>  <i>Clase de prestaciones</i>											

**Application Areas**

Perimeter: *Global*

Staff Function: -

Service Function: -

Business Line: *Infrastructure & Networks*

LOCAL SECTION C- LATAM

ITEM	TITLE	DESCRIPTION
5.5	Ampacity and Short-circuit rating	<p><u>Brazil, Chile, Colombia and Peru</u></p> <p>The ampacity <b>estimated</b> values shall be given for network design purposes. Such currents shall be calculated in steady state condition, for single core laying and four-core visible helix laying, when installed in open air, directly buried and buried in duct using the following operational conditions:</p> <ul style="list-style-type: none"> <li>• Maximum conductor temperature 90 °C</li> <li>• Ambient air temperature 40 °C</li> <li>• Ground temperature 20 °C</li> <li>• Depth of laying 0,8 m</li> <li>• Soil thermal resistivity 1,5 K m/W</li> </ul> <p><u>For Perú</u></p> <p><b>Ampacity</b></p> <p>The ampacity <b>estimated</b> values shall be given for network design purposes. Such currents shall be calculated according to “CNE suministro 2011” using the following conditions:</p> <ul style="list-style-type: none"> <li>• Maximum conductor temperature 90 °C</li> <li>• Ambient air temperature 30 °C</li> <li>• Ground temperature 25 °C</li> <li>• Depth of laying 0,6 m</li> </ul> <p>Soil thermal resistivity 1,5 K m/W</p> <p><b>Short-circuit rating</b></p> <p>The following estimated values could be used as reference for aluminum cables</p>

**Application Areas**

 Perimeter: *Global*

Staff Function: -

Service Function: -

 Business Line: *Infrastructure & Networks*

## LOCAL SECTION C- LATAM

ITEM	TITLE	DESCRIPTION														
5.5	Ampacity and Short-circuit rating	<table border="1"> <thead> <tr> <th>Cross-section [mm<sup>2</sup>]</th> <th>Short circuit rating [kA]</th> </tr> </thead> <tbody> <tr> <td>16</td> <td>1,50</td> </tr> <tr> <td>25</td> <td>2,40</td> </tr> <tr> <td>50</td> <td>4,70</td> </tr> <tr> <td>95</td> <td>8,90</td> </tr> <tr> <td>150</td> <td>14,30</td> </tr> <tr> <td>240</td> <td>22,80</td> </tr> </tbody> </table>	Cross-section [mm <sup>2</sup> ]	Short circuit rating [kA]	16	1,50	25	2,40	50	4,70	95	8,90	150	14,30	240	22,80
		Cross-section [mm <sup>2</sup> ]	Short circuit rating [kA]													
		16	1,50													
		25	2,40													
		50	4,70													
		95	8,90													
		150	14,30													
		240	22,80													
		<p>The short circuit capacities are determined Conductor initial temperature: 90 °C, Conductor final temperature: 250 °C Short-circuit duration: 1 s</p>														
		<p>Argentina</p>														
<p>The ampacity <b>estimated</b> values shall be given for network design purposes. Such currents shall be calculated according to AEA 95101 using the following conditions:</p>																
<p><input type="checkbox"/> Maximum conductor temperature 90 °C</p>																
<p><input type="checkbox"/> Ambient air temperature 30 °C</p>																
<p><input type="checkbox"/> Ground temperature 20 °C</p>																
<p><input type="checkbox"/> Depth of laying 0,7 m</p>																
<p>Soil thermal resistivity 1,5 K m/W</p>																

**Application Areas**

 Perimeter: *Global*

Staff Function: -

Service Function: -

 Business Line: *Infrastructure & Networks*

ITEM	TITLE	DESCRIPTION
8	CONDITIONS OF SUPPLY	<p><u>Argentina, Brazil, Chile, Colombia and Peru</u></p> <p>PACKAGING AND LABELING</p> <p>The conductor will be delivered by the manufacturer in wood or metal drum, which will not be returned, according to maximum and minimum dimensions shown in Table A and according to Figure N° 3.</p> <p>The total length of the driver given on each reel may not be less than requested in the purchase order and shall not exceed by more than <math>\pm 5\%</math>. The maximum gross weight of the reel is packed 2,200 kg.</p> <p>It should protect the ends of each cable reel with caps to prevent moisture ingress and must be internally secured to the spool ends, and must be mechanically protected against possible damages from the handling and transport of each reel, leaving both accessible through the use of internal helix or conch in each reel ends.</p> <p>When the distance between the source of manufacture and storage location of the purchaser involving only a means of transport and less than 200 km away, the use of internal propeller only reels of conductors greater than or equal to 120 mm<sup>2</sup> section is required; this restriction does not release moisture protection of both visible ends of the conductor, mechanical protection and careful handling of the reels.</p>



**Application Areas**

 Perimeter: *Global*

Staff Function: -

Service Function: -

 Business Line: *Infrastructure & Networks*

## LOCAL SECTION C LATAM

ITEM	TITLE	DESCRIPTION										
8	CONDITIONS OF SUPPLY	<p><u>Argentina, Brazil, Chile, Colombia and Peru</u></p> <p>The wooden reels spools will be treated according to international requirements for pest control , avoiding the compound " Pentachlorophenol " and " Creosote " . Treatment should include, at least : high toxicity to decay organisms , high penetration and holding power , chemical stability, non-corrosive to metals and substances affecting physical characteristics of the wood and weather protection</p> <p>Note: The purchase order could specify a maximum length of cable in drum.</p> <div data-bbox="571 958 1420 1444" style="text-align: center;"> </div> <p><b>Figure N° 3 Trial type</b></p> <table border="1" data-bbox="783 1507 1375 1648"> <thead> <tr> <th>A<sup>(1)</sup> mm</th> <th>B mm</th> <th>C <sup>(1)</sup> mm</th> <th>D<sup>(2)</sup> mm</th> <th>E mm</th> </tr> </thead> <tbody> <tr> <td>1730</td> <td>(3)</td> <td>1120</td> <td>80</td> <td>(4)</td> </tr> </tbody> </table> <p>Table A Trial dimension</p> <p>Notes:</p> <p>(1) Maximum value.</p> <p>(2) Minimum value</p> <p>(3) El Double the minimum cable curvature radius for transportation, in accordance with Manufacturer specifications.</p> <p>(4) 300 or 180 mm, in accordance with the type of spool (large or small, respectively)</p>	A <sup>(1)</sup> mm	B mm	C <sup>(1)</sup> mm	D <sup>(2)</sup> mm	E mm	1730	(3)	1120	80	(4)
A <sup>(1)</sup> mm	B mm	C <sup>(1)</sup> mm	D <sup>(2)</sup> mm	E mm								
1730	(3)	1120	80	(4)								

**Application Areas**

 Perimeter: *Global*

Staff Function: -

Service Function: -

 Business Line: *Infrastructure & Networks*

## LOCAL SECTION C LATAM

ITEM	TITLE	DESCRIPTION
8	CONDITIONS OF SUPPLY	<p><u>Brazil, Chile, Colombia</u></p> <p>All spools must:</p> <ol style="list-style-type: none"> <li>1) Be protected by wooden staves on the exterior, which are to be secured to the wooden spools. An equivalent system is to be used on the metal spools. The staves are to be fastened by steel or plastic bands.</li> <li>2) Show the correct direction for unwinding the spools, by means of an arrow located on the sides.</li> <li>3) Have a rustproof nameplate on each side of the spool. Each nameplate will show the following information (as a minimum), in the language of the country where the cable is to be used (Spanish or Portuguese).</li> </ol> <p>The following data will be required:</p> <ul style="list-style-type: none"> <li>• Name of the Manufacturer</li> <li>• Country of origin of the batch</li> <li>• The words: "ENEL GROUP"</li> <li>• Purchase Order number</li> <li>• Maximum voltage between lines</li> <li>• Conductor Material and insulation type</li> <li>• Nominal cross-sectional area (mm<sup>2</sup>)</li> <li>• Number of the spool within the batch</li> <li>• Net weight and gross weight, in kg.</li> <li>• Length of the conductor, in meters.</li> </ul>

**Application Areas**

 Perimeter: *Global*

Staff Function: -

Service Function: -

 Business Line: *Infrastructure & Networks*

## LOCAL SECTION C LATAM

ITEM	TITLE	DESCRIPTION
8	CONDITIONS OF SUPPLY	<p><u>Brazil</u></p> <p>Reels must meet the requirements of the ABNT NBR 11137 (Reels), ABNT NBR 15126 (Performance requirements) and ABNT NBR 6236 (wood for reel) standard</p> <p><u>Peru</u></p> <p>The following data shall be reported on the flange</p> <ol style="list-style-type: none"> <li>1) Enel Distribución Peru</li> <li>2) Name of the manufacturer</li> <li>3) Country of origin of the item</li> <li>4) Country code</li> <li>5) Description of item</li> <li>6) Year and month of manufacture</li> <li>7) Number of the spool within the delivered batch.</li> <li>8) Cable length, in meters.</li> <li>9) the metric initial (m)</li> <li>10) the metric final (m)</li> <li>11) Manufacture standard</li> <li>12) Purchase Order N°</li> <li>13) Rated Voltage (12/20(24) kV)</li> <li>14) Insulation material and type</li> <li>15) Conductor caliber (mm<sup>2</sup>)</li> <li>16) Net weight and gross weight in kg.</li> <li>17) Weight of the coil in kg</li> <li>18) Weight of one meter of cable in kg</li> <li>19) Cable type</li> <li>20) Cable length, in meters.</li> </ol> <p>Coil dimension in mm.</p>
8	CONDITIONS OF SUPPLY	<p><u>Argentina</u></p> <p>Reels must meet the requirements of the IRAM 9590-1 standard</p>

**Application Areas**

 Perimeter: *Global*

Staff Function: -

Service Function: -

 Business Line: *Infrastructure & Networks*

## 9. ANNEXES

### 9.1 CHECK LIST 3X240+150

Item	Description	Unit	Required
<b>1</b>	<b>GENERAL INFORMATION</b>		
1.1	Supplier	-	
1.2	CUI		
1.3	Qualified for FECA03		YES
1.4	Factory Address	-	Qualified Factory Address
<b>2</b>	<b>MAIN FEATURES</b>		
2.1	Global Standard		GSC002 Rev.05 and Addendum
2.3	"Key" Type Code		GSC002/12
2.4	Nominal Voltage $U_0/U(U_{max})$	[kV]	0,6/1,0 (1,2) kV
2.5	Type I, Type II, Type III	-	Type II
2.6	Disposition	[n x mm <sup>2</sup> ]	3x240+150
<b>3</b>	<b>CONDUCTOR</b>		
3.1	Material	-	ALLUMINIUM (99,5%)
3.2	Nominal cross-section	[mm <sup>2</sup> ]	240
3.3	Minimum number of wires of conductor	-	30
3.4	Minimum diameter	[mm]	17,6
3.5	Maximum diameter	[mm]	19,2
3.6	Maximum resistance of conductor at 20°C	[Ω/ km]	0,125
3.7	Stranding Type	-	Compacted circular class 2

**Application Areas**

 Perimeter: *Global*

Staff Function: -

Service Function: -

 Business Line: *Infrastructure & Networks*

Item	Description	Unit	Required
<b>4</b>	<b>INSULATION</b>		
4.1	Material		XLPE/HPTE
4.2	Nominal thickness	[mm]	1,7
4.3	Minimum thickness	[mm]	1,43
4.4	Color	-	Natural (colorless)
4.5	Minimum tensile strength Before ageing	Mpa	12,5
4.6	Minimum tensile strength After ageing	%	±25%
4.7	Insulation Hot Set (200 °C - 15 min - 0,2 MPa)		
a)	Maximum elongation under load	%	175%
b)	Maximum residual elongation	%	15%
4.9	Insulation resistance at 90 °C		
	Volume resistivity	[Ω·km]	10 <sup>12</sup>
4.8	Shrinkage test (1 h- 130°C)		
	Maximum shrinkage		4%
4.9	XLPE in accordance with the requirements of GSC002 REV 06		YES
<b>5</b>	<b>OUTER SHEATH</b>		
5.1	Material		PO
5.2	Nominal thickness	[mm]	1,5
5.3	Minimum thickness	[mm]	1,175
5.4	Color		Black
5.5	Minimum tensile strength Before ageing	Mpa	12,5
5.6	Minimum tensile strength After ageing	%	±25%
5.7	PO Heavy metals content	%	<0,5%
5.8	PO halogen acid gas content	mg/g	≤ 5
5.9	PO gas acidity and conductivity		
a)	Minimum pH	-	4,3
b)	Maximum conductivity	μS/mm	10
5.10	Shrinkage test (200 mm- 5 x5h- 80±2 °C)		
a)	Maximum shrinkage	%	4%
5.11	PO in accordance with the requirements of GSC002 REV 06		YES
6	Reaction to fire test		compliant with IEC 60332-1-2
7	All tests are carried out according to GSC002 REV 06		YES

**Application Areas**

 Perimeter: *Global*

Staff Function: -

Service Function: -

 Business Line: *Infrastructure & Networks*
**9.2 CHECK LIST 1X240 TYPE I**

Item	Description	Unit	Required
<b>1</b>	<b>GENERAL INFORMATION</b>		
1.1	Supplier	-	
1.2	CUI		
1.3	Qualified for FECA03		YES
1.4	Factory Address	-	Qualified Factory Address
<b>2</b>	<b>MAIN FEATURES</b>		
2.1	Global Standard		GSC002 Rev.05 and Addendum
2.3	"Key" Type Code		GSC002/009
2.4	Nominal Voltage $U_0/U(U_{max})$	[kV]	0,6/1,0 (1,2) kV
2.5	Type I, Type II, Type III or Type IV	-	Type I
2.6	Disposition	[n x mm <sup>2</sup> ]	1x240
<b>3</b>	<b>CONDUCTOR</b>		
3.1	Material	-	AA-8000
3.2	Nominal cross-section	[mm <sup>2</sup> ]	240
3.3	Minimum number of wires of conductor	-	30
3.4	Minimum diameter	[mm]	17,6
3.5	Maximum diameter	[mm]	19,2
3.6	Maximum resistance of conductor at 20°C	[Ω/ km]	0,125
3.7	Stranding Type	-	Compacted circular class 2

**Application Areas**

 Perimeter: *Global*

Staff Function: -

Service Function: -

 Business Line: *Infrastructure & Networks*

Item	Description	Unit	Required
<b>4</b>	<b>INSULATION</b>		
4.1	Material	-	XLPE/HPTE
4.2	Nominal thickness	[mm]	1,7
4.3	Minimum thickness	[mm]	1,43
4.4	Color	-	Natural (colorless)
4.5	Minimum tensile strength Before ageing	Mpa	12,5
4.6	Minimum tensile strength After ageing	%	±25%
4.7	Insulation Hot Set ( 135 °C - 15 min - 0,2 MPa)		
a)	Maximum elongation under load	%	175%
b)	Maximum residual elongation	%	15%
4.9	Insulation resistance at 90 °C		
	Volume resistivity	[Ω·km]	10 <sup>12</sup>
4.8	Shrinkage test (1 h- 130°C)		
	Maximum shrinkage		4%
4.9	XLPE in accordance with the requirements of GSC002 REV 06	-	YES
<b>5</b>	<b>OUTER SHEATH</b>		
5.1	Material		PO
5.2	Nominal thickness	[mm]	1,5
5.3	Minimum thickness	[mm]	1,175
5.4	Color		Black
5.5	Minimum tensile strength Before ageing	Mpa	12,5
5.6	Minimum tensile strength After ageing	%	±25%
5.7	PO Heavy metals content	%	<0,5%
5.8	PO halogen acid gas content	mg/g	≤ 5
5.9	PO gas acidity and conductivity		
a)	Minimum pH	-	4,3
b)	Maximum conductivity	μS/mm	10
5.10	Shrinkage test (200 mm- 5 x5h- 80±2 °C)		
	Maximum shrinkage	%	4%
5.11	PO in accordance with the requirements of GSC002 REV 06	-	YES
6	Reaction to fire test	-	compliant with IEC 60332-1-2
7	All tests are carried out according to GSC002 REV 06	-	YES

**Application Areas**

 Perimeter: *Global*

Staff Function: -

Service Function: -

 Business Line: *Infrastructure & Networks*
**9.3 CHECK LIST 1X240 TYPE III**

Item	Description	Unit	Required
<b>1</b>	<b>GENERAL INFORMATION</b>		
1.1	Supplier	-	
1.2	CUI		
1.3	Qualified for FECA03		YES
1.4	Factory Address	-	Qualified Factory Address
<b>2</b>	<b>MAIN FEATURES</b>		
2.1	Global Standard		GSC002 Rev.05 and Addendum
2.3	"Key" Type Code		GSC002/014
2.4	Nominal Voltage $U_0/U$ ( $U_{max}$ )	[kV]	0,6/1,0 (1,2) kV
2.5	Type I, Type II, Type III or Type IV	-	Type III
2.6	Disposition	[n x mm <sup>2</sup> ]	1X240
<b>3</b>	<b>CONDUCTOR</b>		
3.1	Material	-	COPPER
3.2	Nominal cross-section	[mm <sup>2</sup> ]	240
3.3	Minimum number of wires of conductor	-	30
3.4	Minimum diameter	[mm]	17,6
3.5	Maximum diameter	[mm]	19,2
3.6	Maximum resistance of conductor at 20°C	[Ω/ km]	0,125
3.7	Stranding Type	-	Compacted circular class 2



**Application Areas**

 Perimeter: *Global*

Staff Function: -

Service Function: -

 Business Line: *Infrastructure & Networks*

Item	Description	Unit	Required
<b>4</b>	<b>INSULATION</b>		
4.1	Material	-	XLPE/HPTE
4.2	Nominal thickness	[mm]	1,7
4.3	Minimum thickness	[mm]	1,43
4.4	Color	-	Natural (colorless)
4.5	Minimum tensile strength Before ageing	Mpa	12,5
4.6	Minimum tensile strength After ageing	%	±25%
4.7	Insulation Hot Set ( 135 °C - 15 min - 0,2 MPa)		
a)	Maximum elongation under load	%	175%
b)	Maximum residual elongation	%	15%
4.9	Insulation resistance at 90 °C		
	Volume resistivity	[Ω·km]	10 <sup>12</sup>
4.8	Shrinkage test (1 h- 130°C)		
	Maximum shrinkage		4%
4.9	XLPE in accordance with the requirements of GSC002 REV 06		YES
<b>5</b>	<b>OUTER SHEATH</b>		
5.1	Material		PO
5.2	Nominal thickness	[mm]	1,5
5.3	Minimum thickness	[mm]	1,175
5.4	Color		Black
5.5	Minimum tensile strength Before ageing	Mpa	12,5
5.6	Minimum tensile strength After ageing	%	±25%
5.7	PO Heavy metals content	%	<0,5%
5.8	PO halogen acid gas content	mg/g	≤ 5
5.9	PO gas acidity and conductivity		
a)	Minimum pH	-	4,3
b)	Maximum conductivity	μS/mm	10
5.10	Shrinkage test (200 mm- 5 x5h- 80±2 °C)		
a)	Maximum shrinkage	%	4%
5.11	PO in accordance with the requirements of GSC002 REV 06		YES
6	Reaction to fire test		compliant with IEC 60332-1-2
7	All tests are carried out according to GSC002 REV 06		YES