

 	GLOBAL STANDARD	Page 1 of 52
	MV RMU WITH SWITCH-DISCONNECTOR	GSM001 Rev. 00 10/07/2014

This document is intellectual property of ENEL Group distribution companies; reproduction or distribution of its contents in any way or by any means whatsoever is subject to the prior approval of the above mentioned companies which will safeguard their rights under the civil and penal codes.

Revision	Data	List of modifications
00	10/07/2014	First emission

Enel Distribuzione			Endesa Distribución Eléctrica		
Emission	Verification	Approval	Emission	Verification	Approval
DIS/IUN-UML	DIS/IUN-UML	DIS/IUN-UML	EDE/PyE	EDE/PyE	EDE/PyE
D. Lamanna	L. Giansante	R. Lama	J. González	A. Mosegú T. González	F. Giammanco
LATAM			Enel Distributie		
Emission	Verification	Approval	Emission	Verification	Approval
Tecnica LATAM	Tecnica LATAM	Tecnica LATAM	-	Birou Standardizare	Director Dezvoltare Retea
J. C. Mingrone M. García	W. Sciutto M. Del Valle	R. Castañeda	-	V. Obrejan	A. Pascu



MV RMU WITH SWITCH-DISCONNECTOR

GSM001  
Rev. 00  
10/07/2014

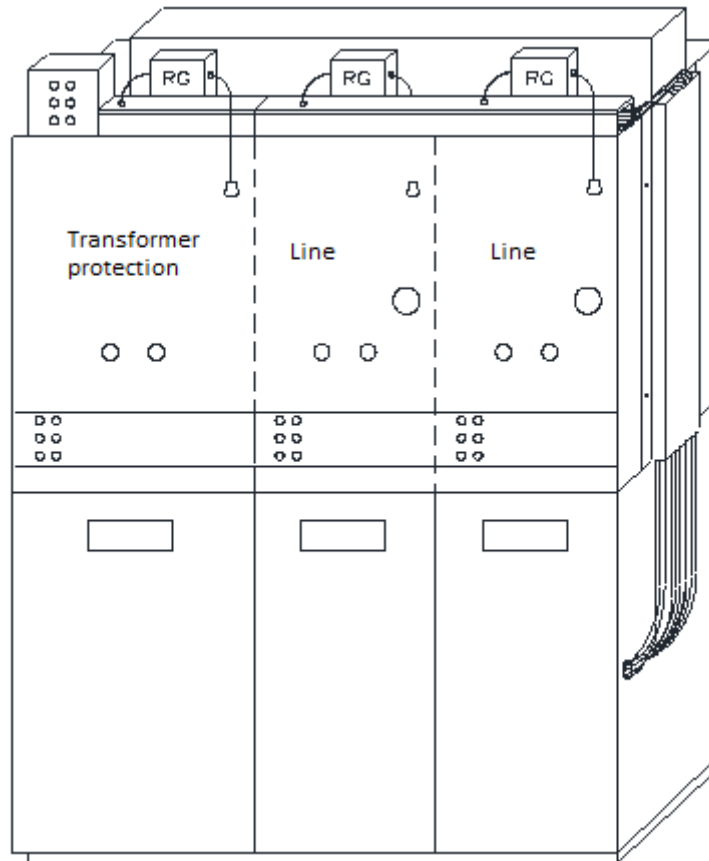

Figure 1: Example of a 2LE+1T RMU

 	GLOBAL STANDARD	Page 3 of 52
	MV RMU WITH SWITCH-DISCONNECTOR	GSM001 Rev. 00 10/07/2014

## INDEX

<b>1. SCOPE</b>	<b>7</b>
<b>2. APPLICATION FIELD</b>	<b>7</b>
<b>3. LIST OF COMPONENTS</b>	<b>7</b>
<b>4. REFERENCE LAWS AND STANDARDS</b>	<b>9</b>
<b>4.1 Laws</b>	<b>9</b>
4.1.1 LATAM	9
4.1.2 Italy	9
4.1.3 Spain	10
4.1.4 All European Countries	10
<b>4.2 Standards</b>	<b>10</b>
4.2.1 Common standards	10
4.2.2 Specific standards	10
4.2.2.1 Enel Distribuzione	11
<b>5. OPERATIONAL CONDITIONS</b>	<b>11</b>
<b>6. RATED CHARACTERISTICS</b>	<b>11</b>
<b>6.1 Characteristics of the switchgear</b>	<b>11</b>
<b>6.2 SF<sub>6</sub></b>	<b>14</b>
<b>6.3 Test values of the MV cables after installation and for searching the faults</b>	<b>15</b>
<b>7. CHARACTERISTICS OF THE SWITCH-DISCONNECTORS</b>	<b>15</b>
<b>7.1 Switch-disconnector operating device</b>	<b>17</b>
7.1.1 Line upright	17
7.1.2 Transformer protection upright	17
7.1.2.1 Auxiliary contact for the opening of the switch-disconnector	17
7.1.2.2 Fuse-carriers and fuses	18
7.1.2.3 Trip coils	18
<b>7.2 Devices and signal position</b>	<b>18</b>
<b>7.3 Interlocking</b>	<b>19</b>
<b>8. SUPPORT FOR THE FAULT DETECTOR DEVICE</b>	<b>20</b>
<b>9. OPERATING DIRECTIONS AND SWITCHGEARS' COMMANDS</b>	<b>20</b>
<b>10. SWITCHGEAR'S CHASSIS</b>	<b>20</b>
<b>11. SUPPORT FOR THE FIXING OF CABLES</b>	<b>21</b>
<b>12. EARTH CONNECTIONS</b>	<b>21</b>
<b>13. PROTECTIVE COATING</b>	<b>21</b>
<b>14. CAPACITIVE DIVIDERS AND VOLTAGE DETECTING SYSTEMS</b>	<b>21</b>
<b>15. BOUNDARIES OF THE SWITCHGEAR'S UPRIGHTS</b>	<b>22</b>

 	GLOBAL STANDARD	Page 4 of 52
	MV RMU WITH SWITCH-DISCONNECTOR	GSM001 Rev. 00 10/07/2014

<b>16. MANOMETER</b>	<b>22</b>
<b>17. SWITCHGEAR'S DIMENSIONS</b>	<b>22</b>
<b>18. NAMEPLATES</b>	<b>22</b>
<b>18.1 Rating plate</b>	<b>23</b>
<b>18.2 Operating sequence nameplate and synoptic scheme</b>	<b>23</b>
<b>18.3 Signal masks on the operating places</b>	<b>23</b>
<b>18.4 Warning nameplate for the switchgear drilling</b>	<b>23</b>
<b>18.5 Label holder</b>	<b>24</b>
<b>18.6 Marks of the phases</b>	<b>25</b>
<b>19. MAINTENANCE</b>	<b>26</b>
<b>20. EQUIPMENT</b>	<b>26</b>
<b>21. EXCEPTIONS TO THIS SPECIFICATION</b>	<b>26</b>
<b>22. TESTING</b>	<b>27</b>
<b>22.1 Type tests</b>	<b>27</b>
22.1.1 Visual inspection	27
22.1.2 Dielectric tests	27
22.1.3 Partial discharge test	27
22.1.4 Measurement of the main circuit resistance	27
22.1.5 Temperature-rise test	27
22.1.6 Short-time withstand current and peak withstand current tests	27
22.1.7 Control of the degree of protection (IP)	28
22.1.8 Tightness tests	28
22.1.9 Tests to verify the tightness with the repeated temperature variations	28
22.1.10 Additional test on auxiliary and control circuits	29
22.1.11 Making and breaking tests	29
22.1.12 Mechanical endurance test	29
22.1.13 Pressure withstand test for gas-filled compartments	30
22.1.14 Additional tests for organic material insulating elements	30
22.1.15 Verification of the protection against rust	30
22.1.16 Internal arc test	31
22.1.17 Verification of switchgear and earthing switches' safe devices	31
22.1.18 Test on bushings capacitive socket	31
22.1.19 Tests on the voltage detecting systems	31
22.1.20 Mechanical strenght test	32
22.1.21 Tests on the fuse-carrier	33
22.1.22 Additional tests for switch-disconnector combined with fuses	33
22.1.23 Test of the kinematic chain in an abnormal working condition	34

 	GLOBAL STANDARD	Page 5 of 52
	MV RMU WITH SWITCH-DISCONNECTOR	GSM001 Rev. 00 10/07/2014

22.1.24 Tests for the verification in humid atmosphere	34
22.1.25 Tests to verify the effectiveness of the protection against pollution	35
<b>22.2 Additional type tests for switch-disconnectors with electrical command DC 24 V<sub>cc</sub></b>	<b>36</b>
22.2.1 Verification of the auxiliary circuits connections	36
22.2.2 Dielectric tests	36
22.2.3 Verification of electrical interlocks functioning	36
22.2.4 Mechanical operation tests with electrical command	36
22.2.5 Characteristics of the electrical command	37
22.2.6 Interruption and subsequent electrical operating completion	37
22.2.7 Interruption and subsequent manual operating completion	37
22.2.8 Verification of the enclosures' degree of protection	38
<b>22.3 Routine tests</b>	<b>38</b>
22.3.1 Visual inspection	38
22.3.2 Dielectric test on main circuit	38
22.3.3 Tests on auxiliary and control circuits	38
22.3.4 Measurement of the resistance of the main circuit	38
22.3.5 Mechanical operation tests	38
22.3.6 Partial discharge measurement	38
22.3.7 Tightness tests	38
22.3.8 Test on bushings and indoor post insulators capacitive socket	38
<b>22.4 Additional routine tests for switch-disconnectors with electrical command DC 24 V<sub>cc</sub></b>	<b>38</b>
22.4.1 Verification of auxiliary circuits connections	39
22.4.2 Dielectric tests	39
22.4.3 Verification of electrical interlocks functioning	39
22.4.4 Mechanical operation tests on the electrical command	39
22.4.5 Characteristics of the electrical command	39
22.4.6 Interruption and subsequent electrical operating completion	39
22.4.7 Interruption and subsequent manual operating completion	39
22.4.8 Verification of the enclosures' degree of protection	39
<b>22.5 Routine tests plan</b>	<b>40</b>
<b>23. LATAM PARTICULAR REQUIREMENTS</b>	<b>42</b>
<b>23.1 Specific standards (seismic)</b>	<b>42</b>
<b>23.2 Specific service conditions</b>	<b>42</b>
<b>23.3 Characteristics of the switchgear</b>	<b>42</b>
<b>23.4 Switchgear's chassis</b>	<b>42</b>
<b>23.5 Support for the fixing of cables</b>	<b>42</b>
<b>23.6 Protective coating</b>	<b>42</b>

 	GLOBAL STANDARD	Page 6 of 52
	MV RMU WITH SWITCH-DISCONNECTOR	GSM001 Rev. 00 10/07/2014

<b>23.7</b>	<b>Switchgear's dimensions</b>	<b>42</b>
<b>23.8</b>	<b>Warning nameplate</b>	<b>43</b>
<b>23.9</b>	<b>Additional type tests for LATAM</b>	<b>43</b>
23.9.1	Seismic test	43
<b>ANNEX A</b>		<b>44</b>
<b>ANNEX B</b>		<b>49</b>
<b>ANNEX C</b>		<b>51</b>

 	GLOBAL STANDARD	Page 7 of 52
	MV RMU WITH SWITCH-DISCONNECTOR	GSM001 Rev. 00 10/07/2014

## 1. SCOPE

The scope of this document is to provide the technical requirements for the supply of SF<sub>6</sub> insulated MV RMUs (Ring Main Unit) with external cone bushings to be used in Secondary Substations of the Enel Group Distribution companies listed below:

- Ampla (Brazil)
- Chilectra (Chile)
- Codensa (Colombia)
- Coelce (Brazil)
- Edelnor (Perú)
- Edesur (Argentine)
- Endesa Distribución Eléctrica (Spain)
- Enel Distributie Banat (Romania)
- Enel Distributie Dobrogea (Romania)
- Enel Distributie Muntenia (Romania)
- Enel Distribuzione (Italy)

Note: the indication "LATAM" refers to the Enel Group Distribution companies in South America.

Some requirements are applicable only to one or more companies. Therefore, depending on the destination, the supplied equipment shall comply with these specific requirements.

## 2. APPLICATION FIELD

MV RMU is an internal installation switchgear to be used in Secondary Substations capable of operating normally, carrying its rated normal current, making and breaking its rated current, in systems with isolated neutral, compensated neutral, neutral with impedance and neutral to the ground.

It is composed by a switch-disconnector with electric (or manual) command and a manual earthing switch for each line. The transformer protection is realized by a manual switch-disconnector with fuses.

RMU configurations may eventually be required in modular solution for exceptional installation conditions; in any case the RMU will be required as a whole.

## 3. LIST OF COMPONENTS

The following components are covered by this global standard:

 	GLOBAL STANDARD	Page 8 of 52
	MV RMU WITH SWITCH-DISCONNECTOR	GSM001 Rev. 00 10/07/2014

Type code	Description	Busbar voltage detector	Extensibility	Command type	Rated normal current [A]	Rated short-circuit breaking current [kA]	Rated voltage [kV]
GSM001/1	2LE+1T	YES	NO	Electrical	630	16	24
GSM001/2	3LE+1T						
GSM001/3	3LE						
GSM001/4	4LE+1T						
GSM001/5	4LE						
GSM001/6	2LE+1T	NO	YES	Manual			
GSM001/7	3LE+1T						
GSM001/8	2LE+2T		NO	Electrical			
GSM001/9	3LE						
GSM001/10	1LE		YES	Manual			
GSM001/11	2L+1T						
GSM001/12	3L+1T		NO	Electrical			
GSM001/13	2L+2T						
GSM001/14	3L		YES	Manual			
GSM001/15	1L						
GSM001/16	1T		NO	NO	Electrical	20	
GSM001/17	2LE+1T						
GSM001/18	3LE+1T						
GSM001/19	2LE+2T						
GSM001/20	3LE						
GSM001/21	1LE	YES	Manual				
GSM001/22	2L+1T						
GSM001/23	3L+1T	NO	Electrical				
GSM001/24	2L+2T						
GSM001/25	1L	YES	Manual				
GSM001/26	1T						

**Table 1: List of components (24 kV)**



 	GLOBAL STANDARD	Page 9 of 52
	MV RMU WITH SWITCH-DISCONNECTOR	GSM001 Rev. 00 10/07/2014

Type code	Description	Busbar voltage detector	Extensibility	Command type	Rated normal current [A]	Rated short-circuit breaking current [kA]	Rated voltage [kV]		
GSM001/27	2LE+1T	NO	NO	Electrical	630	16	36		
GSM001/28	3LE+1T								
GSM001/29	2LE+2T								
GSM001/30	1LE								
GSM001/31	2L+1T		YES	Manual					
GSM001/32	3L+1T								
GSM001/33	2L+2T								
GSM001/34	1L								
GSM001/35	1T		NO	NO		Electrical		20	
GSM001/36	2LE+1T								
GSM001/37	3LE+1T								
GSM001/38	2LE+2T								
GSM001/39	3LE								
GSM001/40	1LE								
GSM001/41	2L+1T			YES		Manual			
GSM001/42	3L+1T								
GSM001/43	2L+2T								
GSM001/44	1L								
GSM001/45	1T								

**Table 2: List of components (36 kV)**

For local components codification see Annex B.

#### 4. REFERENCE LAWS AND STANDARDS

##### 4.1 Laws

##### 4.1.1 LATAM

##### 4.1.1.1 Brazil

NR-10 – segurança em instalações e serviços em eletricidade.

##### 4.1.1.2 Colombia

RETIE – Reglamento Técnico de Instalaciones Eléctricas.

##### 4.1.2 Italy

D.P.R. n. 341 of the 13<sup>th</sup> of February 1981.

D.Lgs n. 81 of the 9<sup>th</sup> of April 2008 and subsequent modifications.

 	GLOBAL STANDARD	Page 10 of 52
	MV RMU WITH SWITCH-DISCONNECTOR	GSM001 Rev. 00 10/07/2014

D.P.R. n. 43 of the 27<sup>th</sup> of January 2012.

#### 4.1.3 Spain

R.D. 3275/1982 de 12 de noviembre. Reglamento sobre condiciones técnicas y garantías de seguridad en centrales eléctricas, subestaciones y centros de transformación e instrucciones técnicas complementarias.

R.D. 614/2001, de 8 de junio, sobre disposiciones mínimas para la protección de la salud y seguridad de los trabajadores frente al riesgo eléctrico.

#### 4.1.4 All European Countries

Regulation (EC) of the European Parliament and of the Council 842/2006 of the 17<sup>th</sup> of May 2006.

Regulation (EC) of the Commission 1494/2007 of the 17<sup>th</sup> of December 2007.

### 4.2 Standards

#### 4.2.1 Common standards

The below listed reference documents shall be intended in the in-force edition at the contract date (amendments included). Unless otherwise specified, these documents are valid until the new editions replace them.

For Latin America destinations the reference standards are the IEC/ISO, whilst for Europe destinations the reference standards are the correspondent European ones (EN).

Standards	Edition
IEC 62271-1	2007-10
IEC 62271-100	2008-04
IEC 62271-102	2001-12
IEC 62271-200	2011-10
IEC 60447	2004-01
IEC 60529	1989-11
EN 50181	2010-07
EN 10346	2009-03
EN ISO 4042	1999-06
IEC 62271-105	2012-09
IEC 62271-103	2011-06
IEC 62271-206	2011-01
IEC 60282-1	2009-10
IEC 61243-5	1997-06

#### 4.2.2 Specific standards

Unless otherwise specified, these standards are valid until the new editions replace them.

 	GLOBAL STANDARD	Page 11 of 52
	MV RMU WITH SWITCH-DISCONNECTOR	GSM001 Rev. 00 10/07/2014

#### 4.2.2.1 Enel Distribuzione

Standards	Edition
DY991	4
DY919	4
DY811	1
DY1050	6
NCDJ4156	1
DJ4135	5
DJ1054	3
DJ1550	3
DMI900002	2
DJ1203	1
PVR006	2

## 5. OPERATIONAL CONDITIONS

Limits of the ambient temperature:

Maximum temperature not over 40 °C with average value, referred to a 24 h period, not over:	35 °C
Minimum ambient air temperature for internal installation:	-15 °C

**Table 3: Limits of the ambient temperature**

For all the other characteristics the reference is the IEC 62271-200, whereas the earthing switch has to comply with the IEC 62271-102.

## 6. RATED CHARACTERISTICS

### 6.1 Characteristics of the switchgear

The switchgear has to be manufactured in compliance with the reference national laws and with the standards pointed out in section 4.2. The main characteristics are listed in table 4.

The enclosures must have a SF<sub>6</sub> volume less than 1500 liters and their filling, to be implemented exclusively in the factory, shall be made in order that the maximum operating relative pressure at 45

°C does not exceed 0,5  $\left[ \frac{kg}{cm^2} \right]$  and they have to form a sealed pressure system (IEC 62271-200).

The bushings for the cables connection shall be outside cone type, in accordance to the EN 50181.

	GLOBAL STANDARD	Page 12 of 52
	MV RMU WITH SWITCH-DISCONNECTOR	GSM001 Rev. 00 10/07/2014

Rated voltage	[kV]	24	36	
Rated insulation level	- impulse withstand voltage to earth and between phases	[kV]	125	170
	- impulse between the open contacts of the line and transformer protection switch-disconnectors	[kV]	145	195
	- power frequency voltage to earth and between phases	[kV]	50	70
	- power frequency voltage between the open contact of the switch-disconnectors	[kV]	60	80
Rated frequency	[Hz]	50/60		
Rated normal current:				
- for busbars and lines	[A]	630		
- for the transformer protection	[A]	200		
Rated short-time withstand current for busbars and connections	[kA]	16/20		
Crest value of the rated short-time withstand current for busbars and connections	[kA <sub>c</sub> ]	40/50		
Rated short-circuit duration	[s]	1		
Degree of protection (for the whole enclosure except for the operating devices)		IP3X		
Degree of protection for the operating devices (even with the operating lever inserted)		IP2XC		
Internal arc classification		IAC		
Type of accessibility		AFL		
Arc test current	[kA]	16/20		
Arc test current duration	[s]	0,5		

**Table 4: Characteristics of the switchgear**

The switchgear must be sealed. The elements used in the factory for filling and recovering the SF<sub>6</sub> at the end of life shall be identified with a self-adhesive plate and protected from accidental shocks. On the plate it shall be written: "*Remove the cap at the end of the switchgear's operating life only for the possible recovery of gas*". This plate shall have a yellow RAL 1021 background and the words in black RAL 9005.

The 24 kV or 36 kV switchgear can be manufactured in a SF<sub>6</sub> insulated single shell containing the busbars, the switch-disconnector and the earthing switches.

During the design and manufacturing of the switchgear, strains during operation and transport must be taken into account; to do this there must be a safety valve against overpressure. The valve shall be equipped with a metal disc for the protection against accidental strains, placed at a proper distance from the valve itself.

The MV fuse-carrier, which shall be protected by a metal enclosure, can be installed inside of the SF<sub>6</sub> shell or outside it.

	GLOBAL STANDARD	Page 13 of 52
	MV RMU WITH SWITCH-DISCONNECTOR	GSM001 Rev. 00 10/07/2014

To connect the MV cable terminals, the switchgear shall be equipped with external cone bushings with capacitive voltage divider in accordance with EN 50181. Bushings shall have a 630 A rated normal current for the lines (type C interface shown in the technical specification NCDJ4156) and 250 A rated normal current for the transformer protection (type A interface for 24 kV switchgears and type B for 36 kV switchgears, shown in the technical specification NCDJ4156), as shown in figure 7. For the characteristics of LATAM MV cables see paragraph 23.

The bushings of the line uprights shall be equipped with capacitive voltage dividers for the supply of the voltage detecting systems. The capacitive voltage dividers shall be standardized, with the characteristics specified in the technical specification DJ1550 and DJ1054 for what applicable.

The switchgear shall be equipped with “safe position devices” for the indication of the real position of the main moving contacts of the switches, as required by IEC 62271-200 and IEC 62271-102.

The functional electric schemes are shown in figures 2 to 4.

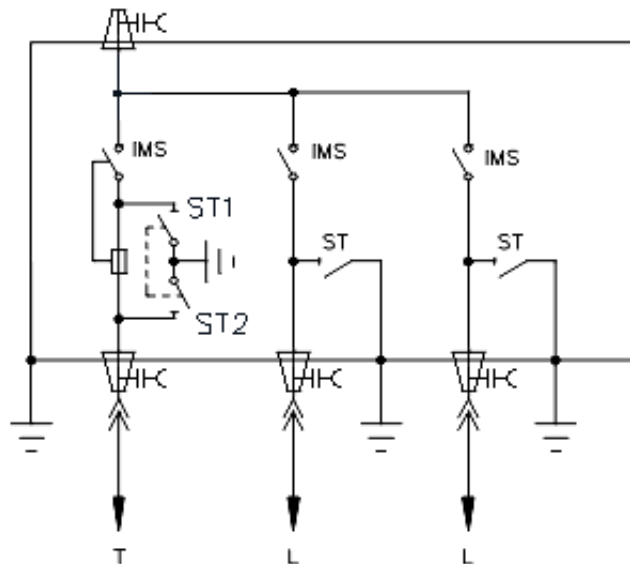

**Figure 2: Functional electric scheme of 2LE+1T type (GSM001/1)**

**Not extensible configuration with capacitive voltage dividers on the busbars**

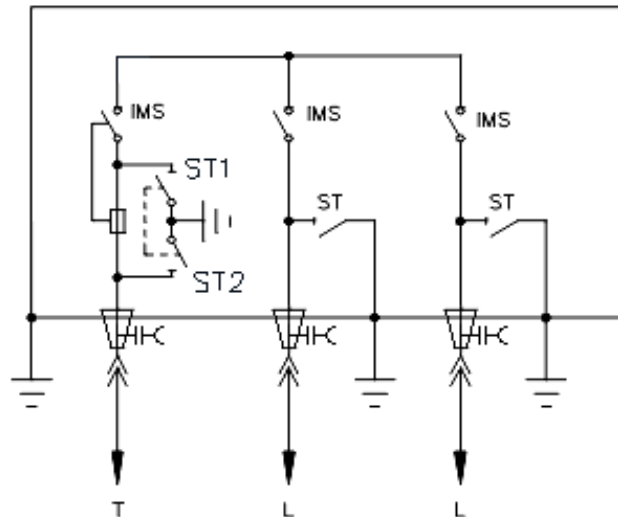

Figure 3: Functional electric scheme of 2LE+1T type (GSM001/6)

Not extensible configuration without capacitive voltage dividers on the busbars

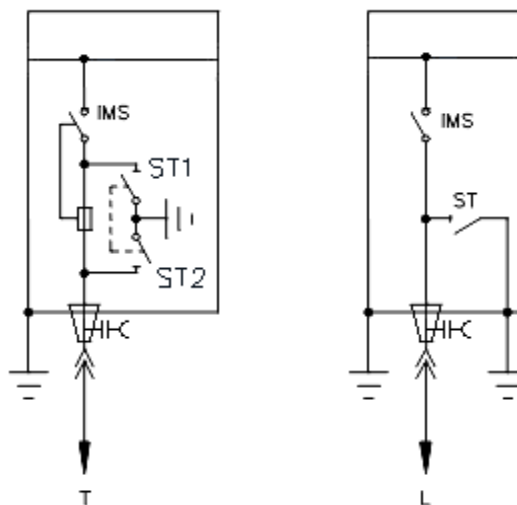

Figure 4: Functional electric schemes of 1T and 1LE types (GSM001/16 - GSM001/10)

Extensible configurations without capacitive voltage dividers on the busbars

## 6.2 SF<sub>6</sub>

The characteristics of the first filling gas shall meet the requirements of IEC 60376. The humidity content of the first filling gas shall be less than 15 ppm in weight and, during operation, the absence of condensation at the minimum operating expected temperatures must be guaranteed. The manufacturer shall ensure that at the end of the expected life of the equipment (30 years) the gas pressure remains greater than (or equal) the minimum operating pressure  $p_m$  (minimum necessary pressure to ensure the performances prescribed for the device). In any case, the loss shall not exceed the 0.1% value in weight per year (IEC 62271-1).

	GLOBAL STANDARD	Page 15 of 52
	MV RMU WITH SWITCH-DISCONNECTOR	GSM001 Rev. 00 10/07/2014

### 6.3 Test values of the MV cables after installation and for searching the faults

The voltage and current applicable values during the test after installation and for searching the faults are shown in table 5.

60 kV, DC, during	15 minutes
For 12/20 kV cables → 24 kV, AC, during	10 minutes
For 18/30 kV cables → 36 kV, AC, during	10 minutes
Maximum current	50 A

**Table 5: Voltage and current applicable values during the test after installation and for searching the faults**

## 7. CHARACTERISTICS OF THE SWITCH-DISCONNECTORS

The switch-disconnectors shall comply with the IEC 62271-105 (transformer protection upright) and the IEC 62271-103 (line upright).

The operating devices of the earthing switches shall be separated from that of the switch-disconnectors and interlocked with them.

The earthing blades must have a manual command only. The movement of the tern of poles has to be simultaneous.

The switch-disconnectors rated characteristics are shown in table 6.

 	GLOBAL STANDARD	Page 16 of 52
	MV RMU WITH SWITCH-DISCONNECTOR	GSM001 Rev. 00 10/07/2014

Rated voltage		[kV]	24	36
Rated insulation level	- impulse withstand voltage to earth and between phases	[kV]	125	170
	- impulse between the open contacts of the switch-disconnectors	[kV]	145	195
	- power frequency voltage to earth and between phases	[kV]	50	70
	- power frequency voltage between the open contacts of the switch-disconnectors	[kV]	60	80
Rated frequency		[Hz]	50/60	
Rated normal current		[A]	630	
Rated short-time withstand current for busbars and connections		[kA]	16/20	
Crest value of the rated short-time withstand current for busbars and connections		[kA <sub>c</sub> ]	40/50	
Rated short-circuit duration		[s]	1	
Mechanical endurance class			M1	
Electrical endurance class			E3	
Rated breaking current	- of a mainly active load	[A]	630	
	- of a no-load transformer	[A]	6,3	
	- of a no-load line	[A]	10	13
	- of a no-load cable	[A]	31,5	40
	- in case of earth fault	[A]	50	
	- with cable-charging in case of earth fault	[A]	16	25
<b>Line earthing switches and ST<sub>1</sub> of the transformer protection:</b>				
- Rated short-time withstand current		[kA]	16/20	
- Crest value of the rated short-time withstand current		[kA <sub>c</sub> ]	40/50	
- Rated short-circuit making current		[kA]	16/20	
- Rated short-circuit duration		[s]	1	
- Electrical endurance class			E2	
- Mechanical endurance class			M0	
<b>ST<sub>2</sub> transformer protection:</b>				
- Rated short-time withstand current		[kA]	1	
- Crest value of the rated short-time withstand current		[kA <sub>c</sub> ]	2,5	
- Rated short-circuit making current		[kA]	2,5	
- Rated short-circuit duration		[s]	1	
Mechanical endurance class			M0	
Electrical endurance class			E2	

**Table 6: Characteristics of the switch-disconnectors and of the earthing switches**



	GLOBAL STANDARD	Page 17 of 52
	MV RMU WITH SWITCH-DISCONNECTOR	GSM001 Rev. 00 10/07/2014

## 7.1 Switch-disconnector operating device

The three-pole manual operating device of the switch-disconnectors has to be deadcenter overcoming both in opening and closing operation, rotary or translational vertical movement (IEC 60447). The operations shall be performed by applying a moment that does not exceed 200 Nm, and the opening and closing speed shall be independent from the action of the operator.

In case that switch-disconnectors and earthing switches are separated, the shaft of the earthing blades shall be mechanically interlocked with that of the line blades operating on the main switch-disconnector shaft and not on the operating shaft.

The switch-disconnectors electrical operating device shall comply with the technical specification DY1050 with a 24 V<sub>cc</sub> auxiliary voltage.

Connections with the remote control peripheral unit (UP) DMI900002, type of connector and pin assignment shall comply with the requirements of DY1050.

It must be allowed to measure the opening and closing speed of the switch-disconnectors and of the earthing switch on the front (e.g., by making accessible the operating shaft of the equipment removing the protective shell only).

The degree of protection of the operating devices, even with the operating lever inserted, shall be IP2XC, in accordance with IEC 60529.

The type codes that, referring to tables 1 and 2, have a manual operating device, shall be supplied without the motor and the connection connector to the UP, but they have to allow the possible future installation in field of these elements.

### 7.1.1 Line upright

The switch-disconnectors can be equipped with electrical control driven by a motor that has the characteristics and the performances required by the technical specification DY1050.

The manual operation of the switch-disconnector shall be possible at any time, regardless of the motorized operation; the insertion of the operating lever for the manual operation must prevent the motorized operation. Such interlock must already act before the end of the lever engages on the tang of whatever operating shafts.

This condition can be realized with both a mechanical (decoupling the gearmotor) and electric solutions (cutting the power of the motor).

An electrical interlock shall permit the motor operation only when the earthing blades are fully open.

### 7.1.2 Transformer protection upright

The switch-disconnector shall have a three-pole manual opening and closing operating device.

At the end of the closing operation, the opening springs of the switch-disconnectors shall be charged. The earthing switches ST<sub>1</sub> and ST<sub>2</sub> shall be equipped with a three-pole manual opening and closing operating device.

#### 7.1.2.1 Auxiliary contact for the opening of the switch-disconnector

To show the open position of the switch-disconnector, a micro-switch shall be provided. This micro-switch shall be put inside the operating device protective shell and shall be able to switch small currents.

Its characteristics shall be those ones written in the technical specification DY1050.

	GLOBAL STANDARD	Page 18 of 52
	MV RMU WITH SWITCH-DISCONNECTOR	GSM001 Rev. 00 10/07/2014

This micro-switch shall be supplied for switchgears with electrical command. As regards the switchgears with manual command, they shall be supplied without the micro-switch, but they shall allow its possible future installation in field.

### 7.1.2.2 Fuse-carriers and fuses

The fuse-carrier is composed by a container made of insulating material and has got an appropriate closing with device that ensures the protection against dust pollutants (degree of protection IP4X - IEC 60529). The container must be accessible without depressurizing the shell of the switchgear and shall be externally protected by a metal earthed shell interlocked with the earthing switch.

The opening of the fuse-carrier must always happen at a pressure which is not dangerous for the operator.

There must be a system that does not go in overpressure or that releases the accumulated pressure before opening.

The shell of the fuse-carrier must prevent the projection of material towards the external part of the switchgear in case of internal overpressure, which may cause its unwanted opening or explosion in case of failure.

The fuse-carrier system shall pass the tests described at paragraph 22.1.21.

The fuses intervention shall be reported on a special slot on the front of the transformer protection upright. The container shall have dimensions that are suitable to the use of fuses with maximum rated voltage of 12 kV, 17.5 kV, 24 kV and 36 kV (characteristics in accordance to IEC 60282-1, Type I and to technical specification DY561). In case of fuses with a rated voltage different from 24 kV or 36 kV, an appropriate adapter must be provided. The removal and replacement of one or more fuses, as a result of their intervention, must be allowed without using tools and insulating greases or similar products. The kinematics of the fuse-carrier, where the striker acts for the opening of the switch-disconnector, shall be preferably made so as to be operated independently from the striker's diameter and, in any case, up to a maximum of 20 mm.

### 7.1.2.3 Trip coils

The switchgears GSM001/6 to GSM001/45 shall be provided with a trip coil. The coil shall operate at 230 V<sub>ac</sub> and perform between 85% and 110% of that voltage. This coil can be connected from the outside feeder circuit and shall be replaced without service interruption.

Other coil operating voltages may be requested. For LATAM see paragraph 23.

The coil circuit shall have a 10 kV insulation towards the metallic grounds of the secondary substations (10 kV, 50 Hz, 1 min).

## 7.2 Devices and signal position

The devices to be provided on the front of the command shall be easily visible and accessible whatever the switch-disconnector's positioning height is referring to its level of installation. The front of the command shall be equipped with the following devices:

- in case of switchgears with electric command, there shall be two buttons for the electrical opening and closing operations. The opening button shall be green with the phrase that corresponds to the Country in which the switchgear shall be delivered; the closing button shall be red with the phrase that corresponds to the Country in which the switchgear shall be delivered. The buttons shall be protected from accidental pressures and shall have a nameplate indicating their performed function;
- operating place for the opening and closing of the switch-disconnector, with the indication of the driving direction, in accordance with figure 9;
- operating place for the opening and closing of the earthing switch, with the indication of the driving direction, in accordance with figures 10 and 11;

	GLOBAL STANDARD	Page 19 of 52
	MV RMU WITH SWITCH-DISCONNECTOR	GSM001 Rev. 00 10/07/2014

Language	Opening	Closing
Italian	APRE	CHIUDE
Spanish	ABRIR	CERRAR
Portuguese	ABRIR	FECHAR
Romanian	DESCHIDE	INCHIDE

Moreover, the following indications shall be provided:

- switch-disconnector's signal position, through the following symbology:
  - black letter "I" on 3000 RAL F2 red background corresponding to the close position of the switch-disconnector;
  - black letter "O" on 6017 RAL F2 green background corresponding to the open position of the switch-disconnector;
- earthing switch's signal position. The used device shall be mechanically interlocked with the main circuit moving contacts and the correspondent position shall be displayed through the following symbology:
  - black letter "I" on 1021 RAL F2 yellow background corresponding to the close position of the earthing switch;
  - black letter "O" on 7030 RAL F2 grey background corresponding to the open position of the earthing switch;

The signal positions shall be visible even with the protection shell removed.

### 7.3 Interlocking

Interlocking and operating directions shall comply with the IEC 62271-200.

Particularly, the line and transformer protection switch-disconnectors and the correspondent earthing switches must not be concurrently closed. The access panel of the cable compartment must be removed only under safe conditions, that is with open switch-disconnector (O) and closed earthing switch (I); this condition shall be made with a mechanical lockable interlock. In all the other cases, the insertion of the padlock must be mechanically forbidden.

Further linkages or interlocks shall not be introduced.

In case there aren't obstruction stoppages, when stressing the switchgears commands in the locked position with a moment of 400 Nm, the contacts of switchgears shall remain in a position where they can maintain their functionality; in case there are obstruction stoppages, it shall be verified that they cannot be removed, if not intentionally and with special tools.

With the access panel of the cable compartment removed, it must not be possible to perform operations, if not under maintenance and using working tools, while still ensuring the IP2X degree of protection for the panel lock. The interlock, once removed, shall return to its initial position when the tool is removed. Always with the panel of the cable compartment removed, it must not be possible, without tools, to remove the blocks and, if the blocks are removed, it must not be possible to replace the panel until the earthing switch is closed.

The access to the transformer protection fuse compartment shall be possible only after the putting out of service operations (open switch-disconnector and closed earthing switches  $ST_1$  and  $ST_2$ ); it shall not be allowed in any other way. The earthing switches  $ST_1$  and  $ST_2$  cannot be opened until the access to the transformer protection fuse compartment is closed. The intervention of one or more fuses must cause the opening of the switch-disconnector; it cannot be closed until the earthing switches  $ST_1$  and  $ST_2$  are open.

Moreover, it shall be provided a point in which a padlock can be inserted in order to lock the operations of the switch-disconnector and of the earthing switches  $ST$ ,  $ST_1$  and  $ST_2$ .

	GLOBAL STANDARD	Page 20 of 52
	MV RMU WITH SWITCH-DISCONNECTOR	GSM001 Rev. 00 10/07/2014

## 8. SUPPORT FOR THE FAULT DETECTOR DEVICE

In the upper part of the switchgear, it shall be provided a support for the fault detector device (as shown in figure 5), one for the cable side of each line upright and only one for the busbar side. These supports must be external and must allow the removal of the command protection shell without being removed.

This support will be supplied already installed in the switchgears with electrical command and shall be provided for possible future installation in field and without service interruption on the switchgears with manual command.

Always in the upper part of the switchgear, it must be provided a cable duct for the external wiring of the cables that connect the motor and the fault detector to the UP.

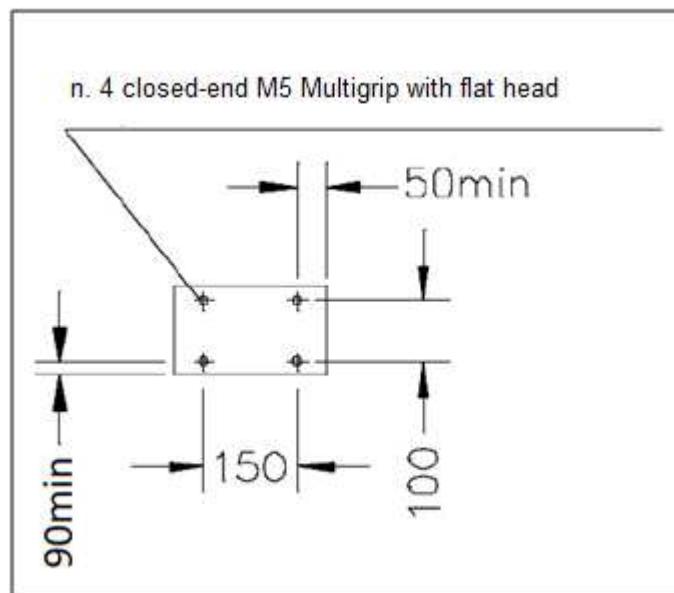

**Figure 5: Support for the fault detector device**

It shall be provided a metal duct with a diameter of 40 mm to connect the bottom of the compartments with the fault detector device.

## 9. OPERATING DIRECTIONS AND SWITCHGEARS' COMMANDS

The operation direction shall be compliant with IEC 60447 and with everything written in this technical specification. For each operating place, it shall be written the function of the device, the movement direction and the "open" or "closed" signal positions. During the operations, the end of the command lever shall not stick out from the two sides of the switchgear.

The switch-disconnectors and the earthing switches shall be preferably operable with a lever compliant with the DY919 technical specification and, in any case, with IEC 62271-1 regarding the delay between the closing and opening operations.

The operating directions must be visible even with the protection shell removed.

## 10. SWITCHGEAR'S CHASSIS

The switchgear's chassis shall have adequate strength, thus taking into account the stresses to which it is subject during transport, handling and operation, and shall comply with EN 13698-1 and the type tests described in paragraph 22.1.20.

	GLOBAL STANDARD	Page 21 of 52
	MV RMU WITH SWITCH-DISCONNECTOR	GSM001 Rev. 00 10/07/2014

## 11. SUPPORT FOR THE FIXING OF CABLES

For the clamp of the MV cables, it shall be provided a steel support with cable stop. For the line uprights it shall be allowed to mount the homopolar CT, which has a 150 mm maximum diameter. For the characteristics of LATAM MV cables see paragraph 23.

## 12. EARTH CONNECTIONS

The earth of the switchgear must be made with a copper wire whose section must not be less than 50 mm<sup>2</sup>.

The operating shafts of the switch-disconnectors and of the earthing switches must be connected to the earth (with conductors whose section must not be less than 30 mm<sup>2</sup>) and to the other metallic objects. This connection is not necessary if the switchgear's internal shaft is made of insulating material.

From the switchgear earthing point, a conductor or a copper bar, whose section must not be less than 50 mm<sup>2</sup>, shall be derived and it shall develop along the entire length of the switchgear and, in correspondence of the line and transformer protection uprights it shall be provided with a M12 bolt on which the earthing connections of the MV cable shields shall be fixed. This conductor or copper bar must allow the connection to the secondary substation's earth from both sides of the external part of the switchgear. For this reason, it shall be provided with two M12 bolts.

The conductor or copper bar shall be realized so that it's not necessary to disassemble, totally or partially, the switchgear by inserting or removing a cable and its corresponding terminal.

## 13. PROTECTIVE COATING

The carpentry in ferrous material shall have a protective coating performed with painting approved cycles as listed in the technical specification DY991/11, whereas it is allowed, just for the covering panels, the terminal cover, the crossbar and support for the external duct of the motorized switchgears, the use of pre-galvanized sheet metal in accordance with EN 10346 with a coating

$$\text{thickness} > 200 \left[ \frac{g}{m^2} \right].$$

The parts in ferrous material of the operating commands shall be protected by an electrolytic coating of 12 μm of zinc on a stainless steel on which it has been applied an iridescent conversion coating (Fe/Zn12/C in compliance with ISO 2081). The assembling nuts and bolts and the small accessories, unless otherwise specified, shall be protected with electrolytic zinc Fe III Zn EN ISO 4042.

## 14. CAPACITIVE DIVIDERS AND VOLTAGE DETECTING SYSTEMS

The capacitive dividers shall have the following characteristics:

Characteristics	Measurement unit	Value	
Rated voltage	[kV]	24	36
Rated frequency	[Hz]	50/60	
Minimum impedance	[MΩ]	100	
Maximum impedance $Z_{max}$	[MΩ]	350	
Minimum voltage ratio $K_{min}$		1/42	
Maximum voltage ratio $K_{max}$		1/20	
Power frequency voltage	[kV]	50	70
Impulse withstand voltage	[kV]	125	170
Puncture voltage	[kV <sub>eff</sub> ]	163	-

	GLOBAL STANDARD	Page 22 of 52
	MV RMU WITH SWITCH-DISCONNECTOR	GSM001 Rev. 00 10/07/2014

The switchgear's type codes GSM001/1 to GSM001/5 shall be equipped with voltage detecting systems that comply with the technical specification DY811. The technical specification for the type tests is the DJ1550.

The switchgear's type codes GSM001/6 to GSM001/45 shall comply with the technical specification DY811 and shall be equipped with an adapter or a separate mechanical/electrical interface (one for each phase and line), mechanically fixed in any case, in accordance with IEC 61243-5 HR or LRM system (to be indicated on the used test point system) to connect a universal phase comparator (UPC). In line positions, together with the voltage detecting system, there shall be a connection point for the fault detector.

These voltage detecting systems shall not require any external power source.

The VDS shall be installed on:

- busbar side, one for type codes GSM001/1 to GSM001/5
- cable side, for every line upright.

For type codes GSM001/1 to GSM001/5, every voltage detecting system, clearly different for each upright, shall be surrounded by a panel upon which "LATO SBARRE" or "LATO CAVI" shall be written.

The bushing of the capacitive divider related to the voltage detecting system "LATO SBARRE" shall be preferably put on the top of the switchgear.

## 15. BOUNDARIES OF THE SWITCHGEAR'S UPRIGHTS

The line and transformer protection uprights must be clearly identifiable, possibly putting appropriate markings (vertical lines, modular panels, etc.). The area affected by the MV cable terminals and the bushings of each upright shall be closed on all sides with metal panels whose thickness must not be less than 1.5 mm; the degree of protection on the front and on the sides shall be IP3X. The access front panels to the cable terminals shall be secured with screws and provided with an electric shock nameplate.

## 16. MANOMETER

To measure the SF<sub>6</sub> pressure, on the type codes to be supplied in Spain a manometer shall be provided.

The manometer shall not be extractable and, in supply normal conditions, the pressure indication shall be between 25% and 75% of the area marked as safe.

## 17. SWITCHGEAR'S DIMENSIONS

The maximum overall dimensions shall be those ones shown in figure 13.

## 18. NAMEPLATES

The nameplates shall be made of anodized aluminum with a 0.8 ÷ 1 mm thickness and shall be secured with screws or rivets. They shall have borders, boxes and white or silver written on opaque black with the exception of the area intended for the company that may be of a different color; the lettering of the required data shall be punched or black printed.

The nameplates can also be adhesive printed with a laser printer; in this case the manufacturer, at the moment of the request, shall submit adequate documentation demonstrating the positive results of the tests carried out to establish the adhesiveness, readability and resistance to various chemical agents; Enel/Endesa/LATAM, however, reserves the right to repeat the tests at manufacturer's expenses in order to verify its statements.

The tests are those ones listed below.



	GLOBAL STANDARD	Page 23 of 52
	MV RMU WITH SWITCH-DISCONNECTOR	GSM001 Rev. 00 10/07/2014

After 48 hours of the application on galvanized or painted support sheet metal, previously degraded, the state of the nameplates and the good adhesion to the support shall not be altered (shrinkage, swelling, peeling or discoloration of the edges or any other type), in result of the following test cycles:

- 48 hours in the oven at 100 °C
- water immersion at 20 °C during 48 hours
- drying at open air during 48 hours
- 48 hours in the oven at 100 °C
- 240 hours under salty fog in accordance with DJ1203

### 18.1 Rating plate

The switchgear's rating plate shall contain information on the code that the manufacturer assigns to each series of the same type. It shall contain the information required by IEC 62271-200 (table 1), IEC 62271-103 (table 2), and IEC 62271-102 (Table 4), such as: manufacturer's name, year and month of manufacture, manufacturer's code, serial number Enel/Endesa/LATAM.

In the rating plate proximity there shall be a barcode with the characteristics described in Nota Operativa Presidio Vendor Rating PVR006.

An informative nameplate with the sentence "Contains fluorinated greenhouse gases covered by the Kyoto Protocol", in accordance with Commission Regulation (EC) 1494/2007 of 17<sup>th</sup> of December 2007, has to be provided.

### 18.2 Operating sequence nameplate and synoptic scheme

The switchgears shall be equipped with an "operating sequence nameplate" on which there shall be the sequence of operations to be executed, respectively, for the access to the switchgear and for the put in service. It shall also contain the switchgear's electric scheme. This nameplate must be positioned on the protective shell of each command so as to be clearly visible.

### 18.3 Signal masks on the operating places

On each line and transformer protection upright, in correspondence of each manual operating place or in another position, signal masks for the position of the devices and the indication of the movement direction for the execution of the operations shall be provided.

### 18.4 Warning nameplate for the switchgear drilling

In a visible location during service, each switchgear shall have a circular nameplate indicating the prohibition on the use of the drill, or similar tool, to avoid the perforation of the shell containing SF<sub>6</sub> in pressure.

 	GLOBAL STANDARD	Page 24 of 52
	MV RMU WITH SWITCH-DISCONNECTOR	GSM001 Rev. 00 10/07/2014

LOGO AND MANUFACTURER'S NAME		
<b>MV RMU GSM001</b>		
TYPE CODE		GSM001/
SERIAL NUMBER		
YEAR OF MANUFACTURE		
APPLICABLE NORM		IEC 62271-200
RATED VOLTAGE	24	kV
RATED FREQUENCY	50	Hz
IMPULSE WITHSTAND VOLTAGE	125	kV
POWER FREQUENCY VOLTAGE	50	kV
RATED NORMAL CURRENT	630	A
RATED SHORT-TIME WITHSTAND CURRENT	16	kA
CREST VALUE OF THE RATED SHORT-TIME WITHSTAND CURRENT	40	kAc
RATED SHORT-CIRCUIT DURATION	1	s
SF6 QUANTITY		kg
INTERNAL ARC CLASSIFICATION	IAC	
TYPE OF ACCESSIBILITY	AFL	
ARC TEST CURRENT	16	kA
ARC TEST CURRENT DURATION	0,5	s
TOTAL WEIGHT		kg
<b>SWITCH-DISCONNECTOR</b>		
APPLICABLE NORMS		IEC 62271-103/105
ELECTRICAL ENDURANCE CLASS		E1
POWER SUPPLY VOLTAGE	24	Vcc
<b>EARTHING SWITCHES</b>		
APPLICABLE NORM		IEC 62271-102
ELECTRICAL ENDURANCE CLASS		E2

**Figure 6: Rating plate**

### 18.5 Label holder

Every upright shall have a label holder with a transparent window of adequate dimensions.





**18.6 Marks of the phases**

In correspondence of EN 50181 bushings, the marks 4 – 8 – 12 to identify the three different phases shall be applied.

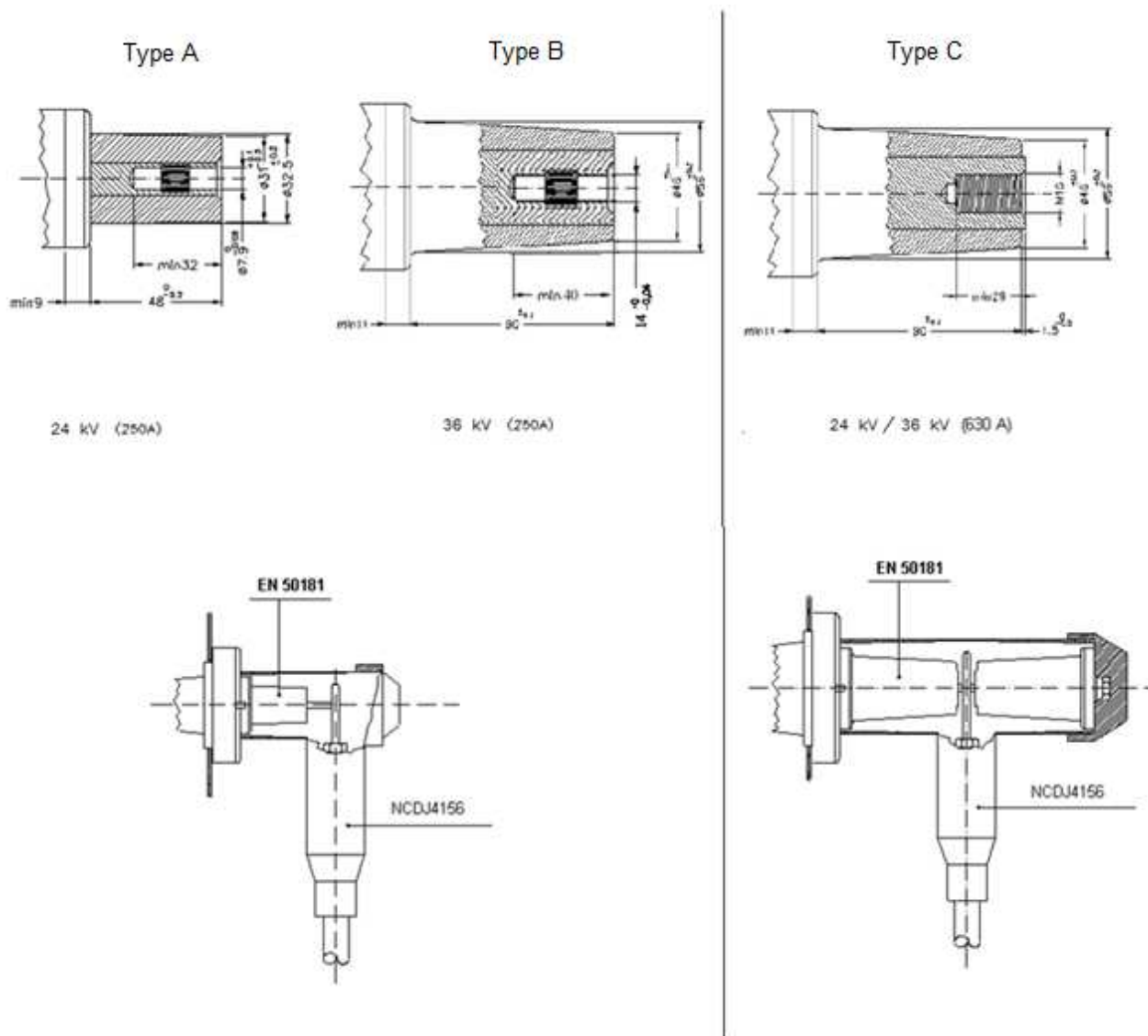

**Figure 7: Bushings**

	GLOBAL STANDARD	Page 26 of 52
	MV RMU WITH SWITCH-DISCONNECTOR	GSM001 Rev. 00 10/07/2014

## 19. MAINTENANCE

The switchgear's type codes GSM001/1 to GSM001/5 shall have, if necessary, a manual, in accordance with the point 10.4 of IEC 62271-1, which shall include the maintenance mode to be observed (e.g., grease on some parts of the command), considering the device type and the period of time in which they have to be carried out. The RMU, for the first 36 months from its delivery date, must be maintenance free. The subsequent maintenance must have a frequency that is not less than 36 months. These statements must be written in the instruction manual.

## 20. EQUIPMENT

Each RMU must be equipped with:

- installation manual in the language of the Country in which the switchgear has to be delivered;
- maintenance manual in the language of the Country in which the switchgear has to be delivered (for type codes GSM001/1 to GSM001/5);
- manual with procedures to be adopted for storage, after factory test and transportation;
- an operating lever for the switches of the lines and transformer protections and a possible operating lever to restore the energy accumulated for the switch-disconnector;
- a connection cable for each motorized upright together with connectors for connecting the switchgear and the UP;
- all adapters for 10 kV and 15 kV fuses (for the switchgear's type codes GSM001/6 to GSM001/45 the adapters are not going to be part of the supply but they may be required, at any time, as optional material after Endesa request). For LATAM see paragraph 23.

Outside of the box containing the RMU, it shall be clearly written:

- name of the Distribution Company (e.g., Enel Distribuzione);
- name of the supplier;
- description of the product;
- code assigned by the supplier;
- type code Enel/Endesa/LATAM and serial number Enel/Endesa/LATAM;
- gross weight.

## 21. EXCEPTIONS TO THIS SPECIFICATION

Any exception to this technical specification, concerning the adoption of techniques and/or special construction different than what is specified in this document, may be taken into account during the homologation process. However, in this case, the Distribution Company reserves the right to prescribe the execution of additional tests other than those ones described in this document, in relation to the specific proposals.

	GLOBAL STANDARD	Page 27 of 52
	MV RMU WITH SWITCH-DISCONNECTOR	GSM001 Rev. 00 10/07/2014

## 22. TESTING

On the switchgear the tests described in the following paragraphs shall be performed.

The making capability of the earthing switch and the pressure leak test, referred to point 6.101 of IEC 62271-200, shall be carried out on a RMU fully prepared to be put in service.

The tests to be performed on the RMUs are divided in:

- Type tests
- Routine tests.

### 22.1 Type tests

During tests maintenance is not allowed.

#### 22.1.1 Visual inspection

The switch-disconnector shall be subject to a visual inspection in order to verify the absence of defects and that the construction features and the dimensions are those ones prescribed in the technical specifications. In detail, it must be verified that the characteristics are correctly shown on the rating plate, as indicated by IEC 62271-200.

#### 22.1.2 Dielectric tests

The tests shall be performed in accordance with IEC 62271-200 § 6.2 and shall be:

- lightning impulse test
- power frequency test
- test on auxiliary and control circuits.

#### 22.1.3 Partial discharge test

The test shall be performed in accordance with IEC 62271-200 § 6.2.9.

The partial discharges control shall be carried out on each bushing or organic material element as indicated in IEC 60270 with the following details:

- partial discharge inception and extinction voltages shall be recorded;
- partial discharge extinction voltage shall not be less than  $1,1 \frac{U_n}{\sqrt{3}}$ , where  $U_n$  represents the switchgear's rated voltage;
- instrument circuit sensitivity shall be able to log a 2 pC discharge intensity;
- instrument circuit background noise shall not be more than 5 pC;
- partial discharges intensity shall not be more than 100 pC at 1,05  $U_n$ .

If it's not possible to remove the bushings or the organic material elements from the switchgear, they shall be picked up by the production.

#### 22.1.4 Measurement of the main circuit resistance

The test shall be performed in accordance with IEC 62271-200 § 6.4, considering the instruction of IEC 62271-105 § 6.4 regarding the use of rigid connections instead of the fuses in the combined switch/fuses.

#### 22.1.5 Temperature-rise test

The test shall be performed in accordance with IEC 62271-200 § 6.5.

#### 22.1.6 Short-time withstand current and peak withstand current tests

The test shall be performed in accordance with IEC 62271-200 § 6.6.

	GLOBAL STANDARD	Page 28 of 52
	MV RMU WITH SWITCH-DISCONNECTOR	GSM001 Rev. 00 10/07/2014

The three-phase test shall be performed with the test current which passes through the switchgear for 1 second. The power supply circuit shall have the conductors rigidly stuck to the bushings or to the terminal-carrier bracket provided on the switchgears. The connection to the tested object shall be made with rigid conductors, whose length is 120 cm. The output connections shall be connected together with flexible conductors.

The test shall be performed both on the line blades and on the earthing blades.

### 22.1.7 Control of the degree of protection (IP)

The control shall be made in accordance with IEC 62271-200 § 6.7, in every part of the switchgear defined in this global standard.

### 22.1.8 Tightness tests

The tests shall be performed in accordance with IEC 62271-200 § 6.8 regarding the “Sealed pressure systems”.

For the tightness tests before and after the mechanical operation test, the switchgear shall be put in a tight enclose during 24 hours.

The measured leaks shall not be more than the annual percentage in weight obtained from the following equation:

$$100 \frac{P_r - P_m}{30P_r}$$

where  $P_r$  represents the value of the relative leaks and  $P_m$  that one of the measured leaks.

Alternatively, to measure the leakage rate, it's possible to use the methods described in § 6.8.2 of IEC 62271-1. The leakage rate shall guarantee a 30 years useful life.

### 22.1.9 Tests to verify the tightness with the repeated temperature variations

The switchgear shall be subject to 20 thermal cycles in accordance with the following figure:

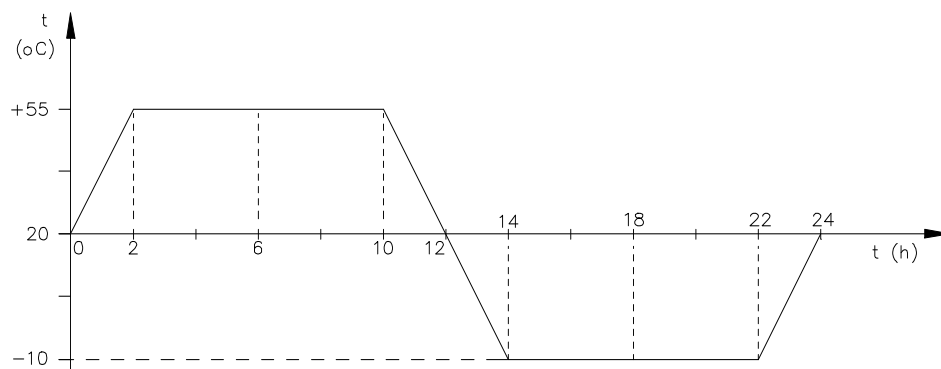

**Figure 8: Thermal cycles to verify the tightness with the repeated temperature variations**

After 6 hours and 18 hours from the beginning of each of the 20 cycles, 2 C-O operations must be performed on the switchgear (SD + ES). Verifications for the leaks determination shall be carried out with the following way:

- one measurement at ambient temperature at the beginning and at the end of the test, in accordance with paragraph 22.1.8.

	GLOBAL STANDARD	Page 29 of 52
	MV RMU WITH SWITCH-DISCONNECTOR	GSM001 Rev. 00 10/07/2014

At the end of the 20 cycles, leaks must not be more than the annual percentage in weight obtained from the equation pointed out in paragraph 22.1.8.

#### 22.1.10 Additional test on auxiliary and control circuits

The test shall be performed in accordance with IEC 62271-200.

The circuit of the trip coil described in paragraph 7.1.2.3 shall pass a power frequency test at 10 kV during 1 minute.

#### 22.1.11 Making and breaking tests

The test shall be performed in accordance with IEC 62271-200 § 6.101 and with the specific standards:

- switch-disconnectors: IEC 62271-103 § 6.101
- earthing switches: IEC 62271-102 § 6.101

The tests include:

- verification of the rated short-circuit breaking current on a mainly active load;
- verification of the rated short-circuit breaking current on a no-load transformer;
- verification of the rated short-circuit breaking current on no-load lines;
- verification of the rated short-circuit breaking current on no-load cables;
- verification of the rated short-circuit making current.

The tests shall be carried out in the two complete switchgears that have got the lowest average speed of the contacts.

Regarding the tests with no-load transformer:

- the power supply circuit is the same of the one used in the test with mainly active loads;
- the load circuit shall be composed by a transformer with the secondary winding closed on a proper reactance;
- the power factor shall be less than 0.1; the circuit natural frequency shall have a value between 100 Hz and 200 Hz; the damping ratio shall have a value between 0.15 and 0.25.

The test cycle shall provide the execution of 100 opening operations as follow:

- 50 operations with a current between 20% and 40% of the no-load transformer rated breaking capability;
- 50 operations with a current between 80% and 100% of the no-load transformer rated making capability.

The maximum permissible over-voltage is 3.5 p.u. towards the earth and 4.5 p.u. between phases<sup>1</sup>.

To verify the making capability, the test cycle includes making operations with a 3 minutes interval.

#### 22.1.12 Mechanical endurance test

The test shall be performed in accordance with IEC 62271-200 § 6.102.

The switch-disconnector's mechanical operation test shall be performed in accordance with IEC 62271-103 § 6.102, whereas the earthing switches' one in accordance with IEC 62271.102 § 6.102.

The mechanical operation tests described in IEC 62271-105 shall be added to the combined switch-fuse.

---

<sup>1</sup> Values p.u. referred to  $\frac{U\sqrt{2}}{\sqrt{3}}$ , where U is the real phase-to-phase testing voltage

	GLOBAL STANDARD	Page 30 of 52
	MV RMU WITH SWITCH-DISCONNECTOR	GSM001 Rev. 00 10/07/2014

At the beginning of the tests, the recording of the opening and closing contacts movement shall be performed on all the samples submitted by the manufacturer: the average speeds of the contacts, from the moment of their separation to that one in which they have made the 25% of their travel and from the moment in which they arrive at the 75% of their travel<sup>2</sup> to that of their connection, shall not differ more than  $\pm 5\%$  on five specimens.

After the execution of 1000 operations, the recording of the contacts movement shall be repeated on the tested specimen: the already defined average speeds of the contacts, at the moment of separation and connection, observed at the end of the tests, shall not differ more than 5% than those ones observed at the beginning of the tests.

If the tested object has got earthing blades, the following tests shall be performed too:

- execution of 1000 complete opening and closing operations on the earthing blades;
- verification of the interlock between the line blades and the earthing blades
  - through the execution of 50 complete opening and closing operations on alternated earthing blades and line blades;
  - if the interlock doesn't forbid the earthing switch operation with switch-disconnector in closed position. In case of switchgears with manual command, there shall be a 40 Nm moment on the earthing blades command shaft with the line blades closed and, subsequently, on the line blades command shaft with the earthing blades closed; in case of switchgears with electric or pneumatic command, it must be verified that, with the earthing blades closed, operating those commands, it's impossible to close the line blades operating on them.

At the end of the tests, the switch-disconnector must work perfectly.

#### 22.1.13 Pressure withstand test for gas-filled compartments

The test shall be performed in accordance with IEC 62271-200 § 6.103.

#### 22.1.14 Additional tests for organic material insulating elements

If the switch-disconnector is equipped with bushings and/or other organic material insulating elements at ambient air and subject to rated voltage, they shall be tested in accordance with the technical specification DJ1203, with the following details:

- paragraph 4.3 of DJ1203 shall not be taken into account;
- the minimum distances between tested objects inside the room shall not be less than 1.5 times the maximum object's dimensions and the distances from the walls shall not be less than 20 cm;
- the test shall be performed applying the rated voltage to the switch-disconnectors. After 20 cycles, the switch-disconnectors shall be washed in demineralized water ( $I \geq 300 \Omega m$ ) and, afterwards, they shall be subject to the tests included in paragraph 22.1.24.

If the switch-disconnector is equipped with an organic material enclosure without a safe earthing connection able to lead every possible leakage current, it shall be subject to the test explained in paragraph 22.1.25.

#### 22.1.15 Verification of the protection against rust

At the end of the previous paragraph test, the switchgear must be able to function perfectly; moreover no trace of rust shall be on the joints, washers, screws, and/or similar pieces. However, some traces of rust are allowed on large pieces when it is clear that any possible development of the area affected by rust cannot lead to a decrease in strength or effectiveness of the switchgear.

<sup>2</sup> The travel is measured as a straight line distance between the closed and open position of the arcing contact

	GLOBAL STANDARD	Page 31 of 52
	MV RMU WITH SWITCH-DISCONNECTOR	GSM001 Rev. 00 10/07/2014

#### 22.1.16 Internal arc test

The test shall be performed in accordance with IEC 62271-200 § 6.106.

#### 22.1.17 Verification of switchgear and earthing switches' safe devices

The switch-disconnector and the earthing switch shall be tested in accordance with points A.6.105.1.3 and A.6.105.2 of IEC 62271-102. These tests are positive if they comply with point A.6.105.3 of the same standard.

#### 22.1.18 Test on bushings capacitive socket

The indoor post insulator or bushings, equipped with voltage capacitive divider for the power supply of the voltage detecting systems, shall be tested taking into account the values of paragraph 22.1.19 in this technical specification and in accordance with DJ1550.

If the indoor post insulator are DJ1054 type, in accordance to the 2<sup>nd</sup> and 3<sup>rd</sup> point of paragraph 22.1.19, the values stated by the manufacturer shall be verified, together with possible influences due to the used layout.

#### 22.1.19 Tests on the voltage detecting systems

The test shall be performed as follow.

Before realizing the tests, the terminal conductors of capacitive dividers shall be connected to the earth of the switchgear. The test to be performed shall be:

- verification of the short-circuit current: the short-circuit current of the capacitive divider shall not be more than 500  $\mu$ A with 24 kV phase-to-phase voltage. To measure this current, it's necessary to remove the possible ballast capacity  $C_z$  and go on indirectly measuring the voltage drop with a voltmeter which has an internal impedance  $Z_i \geq 20$  M $\Omega$  on a capacitive reactance of 0,96 M $\Omega$  (3,3 nF) connected to the two female fastons of the same capacitive divider;
- calculation of  $I_m$  current values, with the following circuit:
  - power supplying the testing upright with a 6,6 kV phase-to-phase voltage (45% of  $8\sqrt{3}$  kV); without voltage in the RMU, 24 kV phase-to-phase voltage, current  $I_m$  shall be more than 2,5  $\mu$ A;
  - power supplying the testing upright with a 2 kV phase-to-phase voltage (5% of  $24\sqrt{3}$  kV); with voltage in the RMU, 24 kV phase-to-phase voltage in every possible configurations, current  $I_m$  shall be less than 2,5  $\mu$ A;
  - power supplying the testing upright with a 24 kV phase-to-phase voltage, current  $I_m$  shall be less (or at least equal) than 35  $\mu$ A.

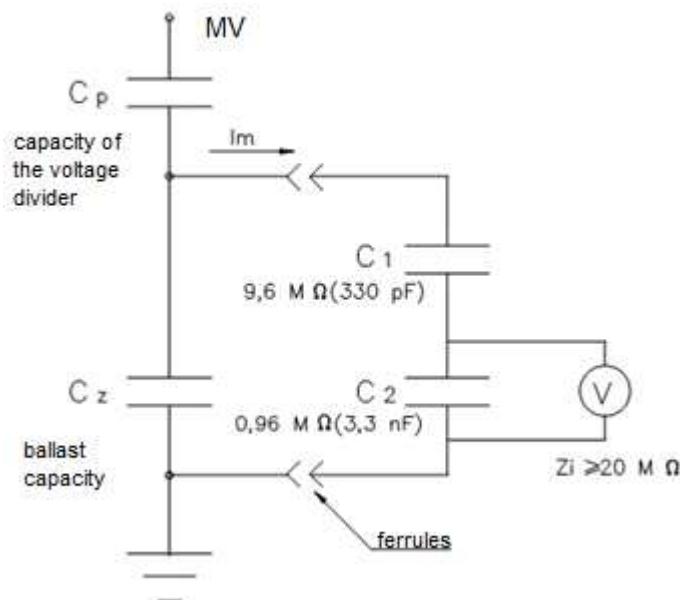

- in the bushes of the fixed part of DY811 device, it shall be inserted a gas discharge lamp, or led one, homologated in accordance with technical specification DY1811 and it shall be verified as follow:
  - power supplying the testing upright with a 6,6 kV phase-to-phase voltage (45% of  $8\sqrt{3}$  kV); without voltage in the RMU, 24 kV phase-to-phase voltage, there shall be the voltage signal with a  $f \geq 0,25$  Hz frequency;
  - power supplying the testing upright with a 2 kV phase-to-phase voltage (5% of  $24\sqrt{3}$  kV); with voltage in the RMU, 24 kV phase-to-phase voltage in every possible configurations, there shall not be the voltage signal ( $f = 0$  Hz frequency);
  - power supplying the testing upright with a phase-to-phase voltage between 2 kV and 6,6 kV, the voltage signal may be present or not.

In addition, the voltage detection systems corresponding to the switchgear's codes GSM001/6 to GSM001/45 shall also satisfy the type tests specified in IEC 61243-5.

### 22.1.20 Mechanical strenght test

On a complete RMU, the following tests shall be performed:

- lifting test: the RMU shall be lifted through the two eyebolts with an additional 250 kg mass, uniformly distributed on the bottom and kept lifted during five minutes;
- strain test: the test consists in securing the RMU to the floor through four bolts and applying 1000 N on each of the two eyebolts, as indicated in the following Fig. 1, during 5 minutes. The test must be repeated applying the same 1000 N in accordance with the following Fig. 2.



	GLOBAL STANDARD	Page 33 of 52
	MV RMU WITH SWITCH-DISCONNECTOR	GSM001 Rev. 00 10/07/2014

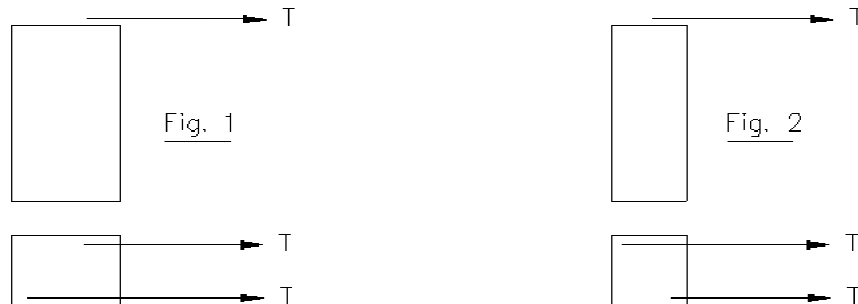

After having completed the tests, permanent strains greater than 3 mm, measured at the base of the roof's vertical, shall not be present. All the electric and mechanical systems shall work perfectly applying a 200 Nm maximum moment.

#### 22.1.21 Tests on the fuse-carrier

The test is divided in two phases.

##### 22.1.21.1 *Safe opening of the cap at rated normal current*

The test shall be performed by keeping the three phases at rated normal current, considering the largest fuse. The current shall be maintained for enough time to get to the temperature stabilization. The temperature shall be detected on the cap of every phase.

The test is positive if there aren't breaks in any fuse-carrier and the cap is not projected outside its place, also during the fuse-carrier opening in isolated and earthed conditions.

##### 22.1.21.2 *Internal arc under fault conditions*

The test shall be performed by connecting a copper wire, with a 0,5 mm diameter, between the fuse-carrier contacts and with the cap inserted.

The test is positive if, by giving a 16 kA current for 30 ms, the fuse-carrier doesn't break or, if it does, it doesn't hit the indicators put in the same way as the internal arc test of the RMU itself (AFL).

#### 22.1.22 Additional tests for switch-disconnector combined with fuses

If the switch-disconnector, excluding the command, is the same one used in the line uprights, during the homologation process it will be asked to realize the following additional tests:

##### 1a) Verification of the release device

This verification shall be made simulating the intervention of the striker of medium type fuses with minimum energy (IEC 60282-1 par. 4.14).

##### 1b) Measurement of the resistance

In addition to the measurement of the resistance in 22.1.4, it shall be verified the resistance at the end of the clamps of the fuse-striker, inserting 63 A fuses and operating at 24 kV or 36 kV, depending on the type of RMU.

##### 1c) Temperature-rise tests

In order to verify the fuse-carrier clamps too, it shall be carried out a temperature-rise test at 40 A, inserting three 63 A fuses or, alternatively, using three sample tubes.

	GLOBAL STANDARD	Page 34 of 52
	MV RMU WITH SWITCH-DISCONNECTOR	GSM001 Rev. 00 10/07/2014

1d) Verification of the signal for fuse intervention

The test shall be performed by tripping the installed fuses twice. At the end of the test, if indicated by an appropriate plate on the shell, it shall be realized the additional operation to take the command also in open position.

When the test is performed as a routine test, it can be carried out with the testing fuse.

**22.1.23 Test of the kinematic chain in an abnormal working condition**

In addition to the test in A.6.105.1.3 of IEC 62271-102 to verify the safe position, the switch-disconnectors which have one or more phases in a different position from those one indicated in the signal device, for their constructive features, in case one or more elements of the kinematic chain break, shall be subject to a test in order to verify, during the homologation process, the reliability of the kinematic chain itself in an abnormal working condition during the type tests repetition.

The test shall be performed, on one switch-disconnector and before closing the shell, by realizing an obstruction at the end of the main contacts travel, before they reach both the open position (or earthing position in case of three positions switch-disconnectors) and the close position.

Testing modalities shall be indicated by the manufacturer, submitting them to Enel/Endesa/LATAM approval that will endorse the documentation in order to ensure the repeatability.

With the command or equivalent system and in order to stress all the elements of the chain, the test shall be realized by applying on the same obstruction and through the moving contacts, a force F and a possible moment M of 1.5 times the value defined by the manufacturer during the design, as indicated by the above-mentioned standard.

The test can be considered positive if no breaks occur.

**22.1.24 Tests for the verification in humid atmosphere**

1a) Dielectric dry test

The switch-disconnectors shall be held during 24 hours without voltage in the test room at a  $20 \pm 2$  °C temperature and with relative humidity less than 80%, in order to obtain their complete drying. They shall then be subject to dry power frequency test during 1 minute.

1b) Tests for the verification in humid atmosphere

The test room temperature shall then be increased to  $30 \pm 2$  °C with relative humidity above 95%. The achievement of these environmental conditions is carried out by placing steam and compressed air alternating the phases. After the switch-disconnector spent 3 hours under the above-mentioned conditions without voltage, it shall be applied the maximum rated voltage  $U_m$  divided for  $\sqrt{3}$  during 1 hour. The test voltage is then increased continuously until  $U_m\sqrt{3}$  and here kept during 30 seconds.

The voltage application shall be performed cyclically on each phase by connecting to the earth the phases not under test. The trend of the main parameters is shown in the following figure.

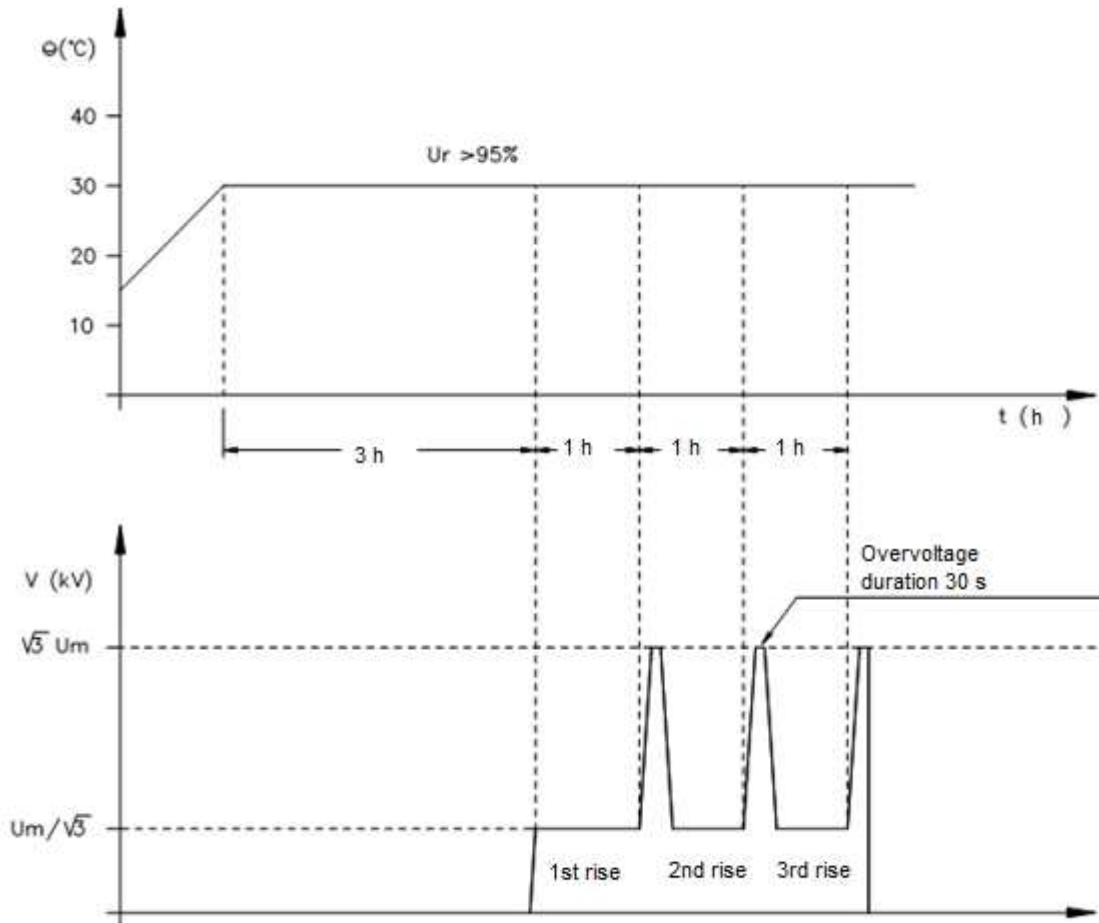

### 22.1.25 Tests to verify the effectiveness of the protection against pollution

Referring to point 5.102 of IEC 62271-102, in the absence of a safe connection to earth, to verify the effectiveness of the protection against pollution in service of the insulating materials, it shall be performed the following test:

1) with the switch-disconnector isolated, it shall be applied a 60 kV power frequency voltage (for 24 kV RMU) or 80 kV power frequency voltage (for 36 kV RMU) between inlet and outlet, measuring the leakage current<sup>3</sup>

2) the switch-disconnector is then subject to the following cycle, that simulates a 10 years electrical service life to be repeated 3 times:

- 20 openings at 100 Arms and  $\cos\phi = 0,7$
- 8 closings at 4 kArms and  $\cos\phi = 0,15$
- 15 closings at 3 kArms and  $\cos\phi = 0,15$
- 10 openings at 100 Arms and  $\cos\phi = 0,7$
- 30 closings at 200 Arms and  $\cos\phi = 0,7$
- 37 closings at 2 kArms and  $\cos\phi = 0,15$

<sup>3</sup> In case of a discharge towards the earth, the switchgear shall be properly isolated towards the earth.

	GLOBAL STANDARD	Page 36 of 52
	MV RMU WITH SWITCH-DISCONNECTOR	GSM001 Rev. 00 10/07/2014

- 15 closings at 1 kArms and  $\cos\phi = 0,15$
- 15 openings at 100 Arms and  $\cos\phi = 0,7$

3) the switch-disconnector shall be subject to the tests of the previous point 1.

The test result is positive if there are no discharges on the sectioning and if the leakage current value doesn't exceed 30 mA.

## 22.2 Additional type tests for switch-disconnectors with electrical command DC 24 V<sub>cc</sub>

In addition to type and routine tests, described in paragraphs 22.1 and 22.3, also the following tests shall be performed on the switch-disconnector with electrical command.

Tests from 22.2.1 to 22.2.8 must be performed in accordance with what specified in the following paragraphs and without voltage on the main circuits; the mechanical operation test, described in 22.1.12, shall be carried out with the variants and integrations provided in 22.2.4.

In details, after the test described in 22.2.4 (and possible 22.2.4.1), tests from 22.2.5 to 22.2.8 shall be performed on the same specimen and without maintenance.

### 22.2.1 Verification of the auxiliary circuits connections

It shall be verified the correspondence of the connections to the electric scheme approved by Enel/Endesa in accordance with the technical specifications DY1050 and DY811.

### 22.2.2 Dielectric tests

Before beginning the tests, motor conductors and surge suppressors must be disconnected and properly isolated (leaving connected the possible coupling device).

In accordance with § 6.106 of IEC 62271-1, tests shall be performed applying a 2 kV (or 10 kV) power frequency voltage during 1 minute to the clear end of the conductors of the supply connection cable (the other end is connected to the command).

### 22.2.3 Verification of electrical interlocks functioning

The electrical command must be forbidden in the following conditions:

- the earthing switch is not in open position;
- the lever for the manual operation of the switch-disconnector's blades is being inserted (the prohibition must already act before the end of the lever engages on the tang of the operating shaft).

Particular attention shall be put to verify the interlocks functioning in case a supply interruption occurs when the mechanism is close to the deadcenter, so immediately before the switch-disconnector could be operated.

### 22.2.4 Mechanical operation tests with electrical command

The switch-disconnector shall be subject to 1000 C-O operating cycles, as indicated in 22.1.12, under the following conditions:

 	GLOBAL STANDARD	Page 37 of 52
	MV RMU WITH SWITCH-DISCONNECTOR	GSM001 Rev. 00 10/07/2014

Number of cycles	Temperature [°C]	Voltage [V <sub>cc</sub> ]
250	45	28,8
250	45	19,2
250	-15	19,2
250	-15	28,8

The 250 cycles shall be performed with 1 cycle every 30 seconds.

All the operations shall be realized sending command impulses  $\leq 300$  ms.

At the end of the 1000 cycles, other 50 cycles shall be made with manual command and at ambient temperature.

Before and after the mechanical operation tests, the average speed of the contacts shall be measured in accordance with the requirements in 22.1.12.

At the end of the mechanical operation tests, opening and closing operating times shall be recorded, together with the motor and the possible coupling device absorption; the obtained values shall not differ more than  $\pm 10\%$  respect those ones obtained during the test in 22.2.5.

#### 22.2.4.1 *Mechanical operation tests with motor entrainment*

Before the operations with electrical command described in the previous paragraph, if during the electrical operation the motor is completely or partially drag (excluding the first operation), 100 manual operations shall be made on the switch-disconnector, recording the absorption before and after so as to verify that there are no damages.

#### 22.2.5 **Characteristics of the electrical command**

Opening and closing operating times shall be recorded, together with the absorbed power at minimum, rated and maximum supply voltage.

For the possible coupling device, only the absorbed power shall be recorded at minimum, nominal and maximum values.

For the other electrical components used on the electrical command, the manufacturer shall give specific documentation in accordance with this global standard. Enel/Endesa/LATAM reserves the right to prescribe additional tests.

#### 22.2.6 **Interruption and subsequent electrical operating completion**

After having caused a supply interruption during opening and closing operations, it must be verified that there aren't anomalies during the subsequent electrical operating cycles (3 O-C and 3 C-O).

#### 22.2.7 **Interruption and subsequent manual operating completion**

After having caused a supply interruption during opening and closing operations, it must be verified that there aren't anomalies during the subsequent manual operating cycles (3 O-C and 3 C-O).

	GLOBAL STANDARD	Page 38 of 52
	MV RMU WITH SWITCH-DISCONNECTOR	GSM001 Rev. 00 10/07/2014

### 22.2.8 Verification of the enclosures' degree of protection

It shall be verified the degree of protection (IEC 60529) on all the components used on the electrical command, whose characteristic has been specified in this global standard.

## 22.3 Routine tests

### 22.3.1 Visual inspection

It shall be performed on a random switch-disconnector among those ones that belong to the batch submitted to the commissioning.

The control shall be made comparing the constructive and dimensional features with those ones in the drawings and pictures approved by Enel/Endesa/LATAM and kept by the manufacturer.

### 22.3.2 Dielectric test on main circuit

The test shall be performed in accordance with IEC 62271-200 § 7.1.

### 22.3.3 Tests on auxiliary and control circuits

The test shall be performed in accordance with IEC 62271-200 § 7.2.

### 22.3.4 Measurement of the resistance of the main circuit

The test shall be performed in accordance with IEC 62271-200 § 7.3.

### 22.3.5 Mechanical operation tests

The test shall be performed in accordance with IEC 62271-200 § 7.102.

The contact speeds, measured as indicated in 22.1.12, shall not differ more than  $\pm 10\%$  from the average values obtained during the type tests for the homologation of the products.

### 22.3.6 Partial discharge measurement

The manufacturer shall provide appropriate documentation stating the regular partial discharge test during the own production cycles. Enel/Endesa/LATAM reserves the right to realize additional tests on organic material elements taken during the production process.

### 22.3.7 Tightness tests

The manufacturer shall self-certify the measure on each RMU, as indicated in IEC 62271-200 § 7.4.

### 22.3.8 Test on bushings and indoor post insulators capacitive socket

Giving power supply to the switch-disconnector, it shall be verified the ignition of the voltage detecting system lights.

Moreover, it shall be verified the correct wiring, ballast capacity (if it's on the homologation documents) and the conformity of the insulator type with its documentation.

The voltage detection systems corresponding to the switchgear's codes GSM001/6 to GSM001/45 shall also satisfy the routine tests specified in IEC 61243-5.

## 22.4 Additional routine tests for switch-disconnectors with electrical command DC 24 V<sub>cc</sub>

Tests from 22.4.1 to 22.4.8 shall be performed in accordance with the following modalities and without voltage on main circuits.

	GLOBAL STANDARD	Page 39 of 52
	MV RMU WITH SWITCH-DISCONNECTOR	GSM001 Rev. 00 10/07/2014

Mechanical operation test, described in 22.3.5, shall be made under the conditions stated in 22.4.4; in detail, tests from 22.4.6 to 22.4.8 shall be performed, after that test, on the same specimens and without maintenance.

#### **22.4.1 Verification of auxiliary circuits connections**

As indicated in 22.2.1, the same tests shall be performed on the sampling.

#### **22.4.2 Dielectric tests**

The tests shall be performed with the same modalities described in 22.2.2.

#### **22.4.3 Verification of electrical interlocks functioning**

The tests shall be performed with the same modalities described in 22.2.3.

#### **22.4.4 Mechanical operation tests on the electrical command**

The switch-disconnector shall be subject to 20 electrical C-O cycles at ambient temperature, 10 at maximum voltage and 10 at minimum voltage, one every minute. The main contacts speeds shall not differ more than  $\pm 10\%$  from the average values obtained during the homologation tests.

After having completed the 20 cycles with the electrical command, other 2 shall be performed with manual command.

#### **22.4.5 Characteristics of the electrical command**

The tests shall be performed on one specimen of the sampling, with the same modalities indicated in 22.2.5.

#### **22.4.6 Interruption and subsequent electrical operating completion**

The test shall be made for 2 C-O cycles with the same modalities indicated in 22.2.6.

#### **22.4.7 Interruption and subsequent manual operating completion**

The test shall be made for 2 C-O cycles with the same modalities indicated in 22.2.7.

#### **22.4.8 Verification of the enclosures' degree of protection**

On one specimen of the sampling, it shall be verified the degree of protection of the shell and enclosures, in accordance with 22.2.8.

	GLOBAL STANDARD	Page 40 of 52
	MV RMU WITH SWITCH-DISCONNECTOR	GSM001 Rev. 00 10/07/2014

## 22.5 Routine tests plan

All the routine tests indicated in the following table shall be carried out by the supplier on all the samples prepared for the commissioning. For each piece that belongs to the prepared batch, the supplier shall prepare a test report with the results of the tests performed.

The test, under Enel/Endesa/LATAM surveillance, shall be carried out on a sample chosen randomly among those ones of the batch that has already been successfully tested by the supplier. The tests shall be carried out on samples defined by the sampling plan below.

At the end of the commissioning, within the measurement uncertainty, there shall not be differences between the measured values and those ones in the acceptance ranges of the approved test values.

In case of commissioning attended by Enel/Endesa/LATAM, the entire batch will be rejected if the results of one of any test is negative.

A	1 sample for type
B	At least 1 sample for type (serial number Enel/Endesa/LATAM) prepared for commissioning with at least 3 total samples
D	documentation check

**Table 7: Sampling plan**

N.	TEST	RMU	Line upright	TR upright
1	Visual inspection (a)	A		
2	Dielectric tests on auxiliary and control circuits (b)		B	B
3	Verification of auxiliary circuits connections		B	B
4	Mechanical operation tests (c)		B	B
5	Verification of the release device			B
6	Verification of the signal for fuse intervention			B
7	Interruption and subsequent electrical operating completion		B	
8	Interruption and subsequent manual operating completion		B	
9	Characteristics of the electric command		A	
10	Measurement of main circuits resistance (d)		B	B
11	Tests on voltage detecting system (e)	B		
12	Dry power frequency tests on main circuit (f)	B		
13	Verification of proactive coating (g)	B - A		
14	Partial discharges control for organic material elements	D		
15	Tightness tests (h)	D		

**Table 8: Testing plan**



 	GLOBAL STANDARD	Page 41 of 52
	MV RMU WITH SWITCH-DISCONNECTOR	GSM001 Rev. 00 10/07/2014

a	Including the verification of the enclosures' degree of protection (IP)
b	2 kV power frequency testing voltage (10 kV for trip coil) during 60 seconds
c	<ul style="list-style-type: none"> <li>On the earthing switch and on the switch-disconnector, 5 closing operations and 5 opening operations verifying the mechanical interlocks functioning (DY1132 par. 6.4.1 and IEC 62271-200 § 7.102). On the earthing switch, it shall be measured the main contacts closing speed during the last operation.</li> <li>Only on the switch-disconnector of the line upright, mechanical operation tests shall be realized in accordance with IEC 62271-103 § 7.101. In case of electrical command, the maximum voltage shall be <math>V_{max}</math> (28,8 <math>V_{cc}</math>) and the minimum one <math>V_{min}</math> (19,2 <math>V_{cc}</math>). It shall be recorded the opening and closing main contacts speed only during the last operation of every sequence. During all the operations, all the electrical interlocks shall be verified ( § 22.4.3 and DY1132 § 6.4.1).</li> </ul>
d	Test to be performed on the same configuration used during the homologation process.
e	Verification of the correct wiring and the ignition of the lights of the voltage detecting system, both "LATO SBARRE" and "LATO CAVI".
f	The test shall be performed with the operating devices closed and on the sectioning distance. All the tests shall be performed at a 50 kV power frequency voltage (for 24 kV RMU) or 70 kV power frequency voltage (for 36 kV RMU).
g	Verification of the thickness with sampling plan "B" and verification of adherence on one sample.
h	Test to be certified on single units by the supplier

**Table 9: Additional information**

	GLOBAL STANDARD	Page 42 of 52
	MV RMU WITH SWITCH-DISCONNECTOR	GSM001 Rev. 00 10/07/2014

### 23. LATAM PARTICULAR REQUIREMENTS

The information contained in this paragraph refer to LATAM particular requirements.

For all the other characteristics which are not explained here, it shall be applied what has been said in the previous paragraphs.

#### 23.1 Specific standards (seismic)

##### Chilectra

ETGI-1020 - Especificaciones técnicas generales - Requisitos de diseño sísmico para equipo eléctrico.

##### Codensa

NSR - 10 Norma Sismo Resistente Colombiana.

##### Edelnor

E-SE-010 - Acción sísmica en equipos eléctricos y mecánicos.

#### 23.2 Specific service conditions

##### Colombia (Codensa)

The reference altitude is 2.600 m.

#### 23.3 Characteristics of the switchgear

All the characteristics are described in paragraph 6, except for the following:

Arc test current	[kA]	16
Arc test current duration	[s]	1

#### 23.4 Switchgear's chassis

In addition to what has been written in paragraph 10, the seismic requirements of paragraph 23.1 shall be considered for Chilectra, Codensa and Edelnor according to the standards. The manufacturer shall submit a seismic calculation (analysis) for the Client's approval.

#### 23.5 Support for the fixing of cables

It shall be considered that LATAM distribution companies use different cable sections:

- Codensa: up to 240 mm<sup>2</sup>
- Edelnor: up to 400 mm<sup>2</sup>
- Edesur: up to 500 mm<sup>2</sup>
- Chilectra: up to 630 mm<sup>2</sup>

Characteristics of other MV cables are according to Global Standard GSC001.

#### 23.6 Protective coating

Alternative protective treatments to the ones indicated in paragraph 13 could be accepted if the manufacturer proves their fitness.

#### 23.7 Switchgear's dimensions

The maximum height is 1.900 mm for 24 kV configurations and 2.000 mm for 36 kV configurations.

	GLOBAL STANDARD	Page 43 of 52
	MV RMU WITH SWITCH-DISCONNECTOR	GSM001 Rev. 00 10/07/2014

### 23.8 Warning nameplate

#### Codensa

As required by RETIE (see paragraph 4.1.1.2), equipments shall show the following labeling on the front of the switchgear.

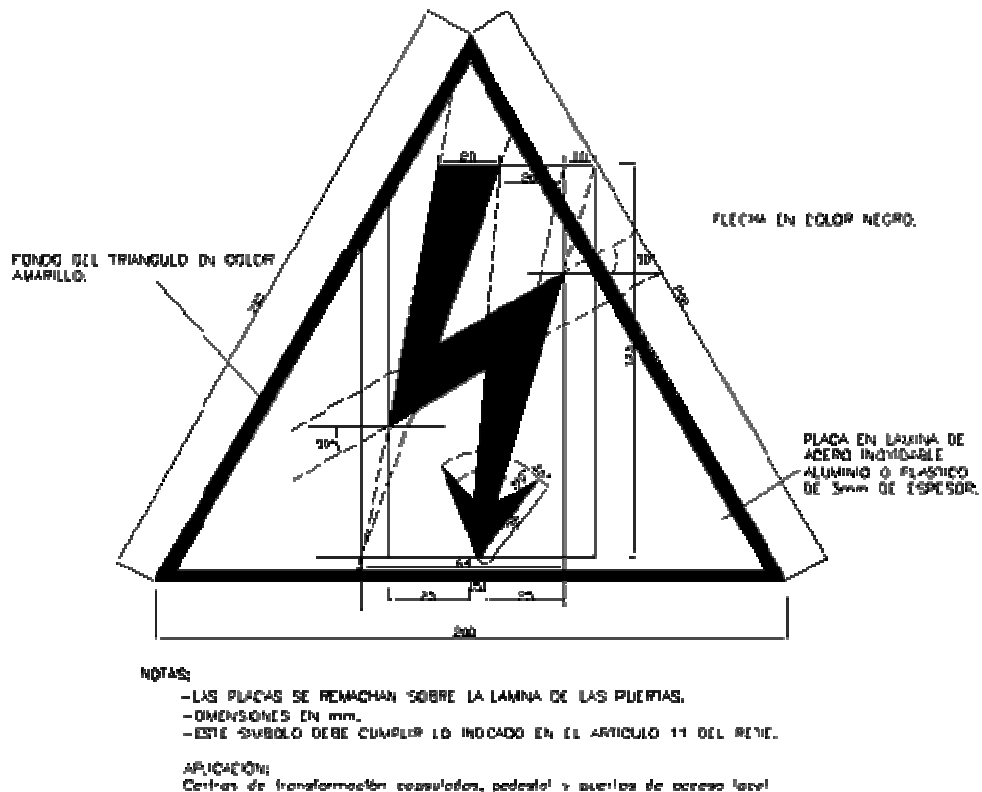

- Triangle background: yellow
- Arrow: black
- Plate: stainless steel, aluminum or 3 mm thick plastic
- The plate is riveted to the door plate
- Dimensions are in mm
- This sign shall comply with the terms of article 11 of RETIE
- To be placed in: transformer stations, pedestals and local access doors

### 23.9 Additional type tests for LATAM

#### 23.9.1 Seismic test

The manufacturer shall produce a report to demonstrate the required seismic qualification level indicated in paragraph 23.1.

	GLOBAL STANDARD	Page 44 of 52
	MV RMU WITH SWITCH-DISCONNECTOR	GSM001 Rev. 00 10/07/2014

## ANNEX A

The manufacturer shall specify, in detail, data and information listed below.

### General part

- Overall dimensional drawing with:
  - switch-disconnector and earthing switch position of the operating devices;
  - MV fuses position of the transformer protection upright, referring in detail to the lock devices, their access and extraction;
  - position of the MV terminal cables;
  - dimension and position of the safety valve against overpressure;
  - position and characteristics of the point for SF<sub>6</sub> control;
  - position of the earthing point;
  - homologated protective coating.
- Single-line electrical scheme of the main circuits and functional scheme of the auxiliary circuits.
- Drawing of the rating plate with the indication of the name given by the manufacturer.
- Maintenance plan, pointing out the characteristics of the resources to be used (people, lifting machines, plant for gas treatment, special tools, etc.).
- SF<sub>6</sub> pressure at 20 °C:
  - p<sub>r</sub>: filling pressure to be verified during routine tests;
  - p<sub>m</sub>: minimum necessary pressure to ensure the prescribed characteristics;
  - characteristics of the devices for SF<sub>6</sub> pressure control in service;
  - intervention pressure of the safety valve against overpressure.
- Documentation to demonstrate the dielectric strength of the internal insulators for the arc dispersion products.
- Characteristics of the resin used for the insulators.
- List of type B documentation.
- Photos of the switchgear.

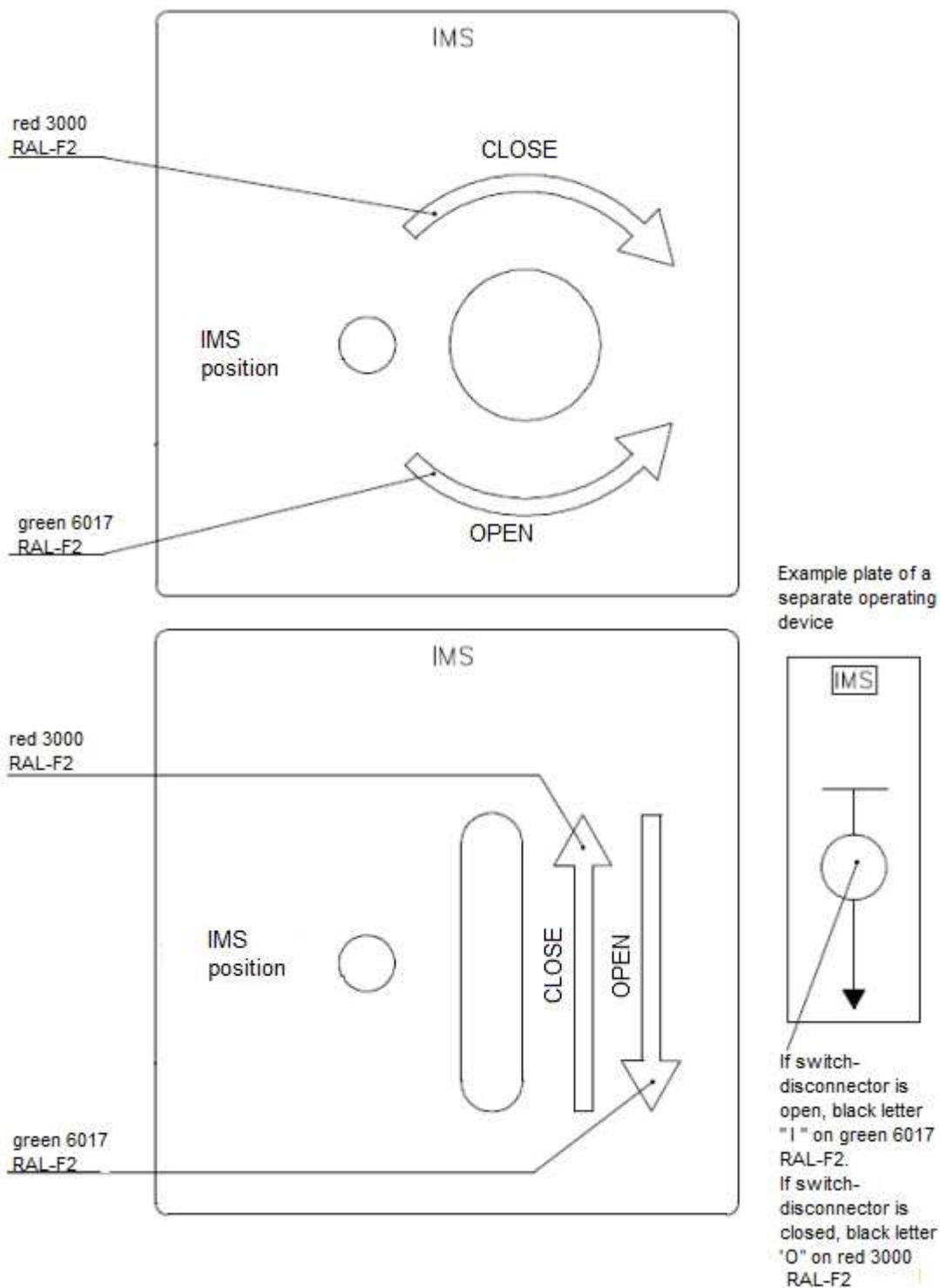
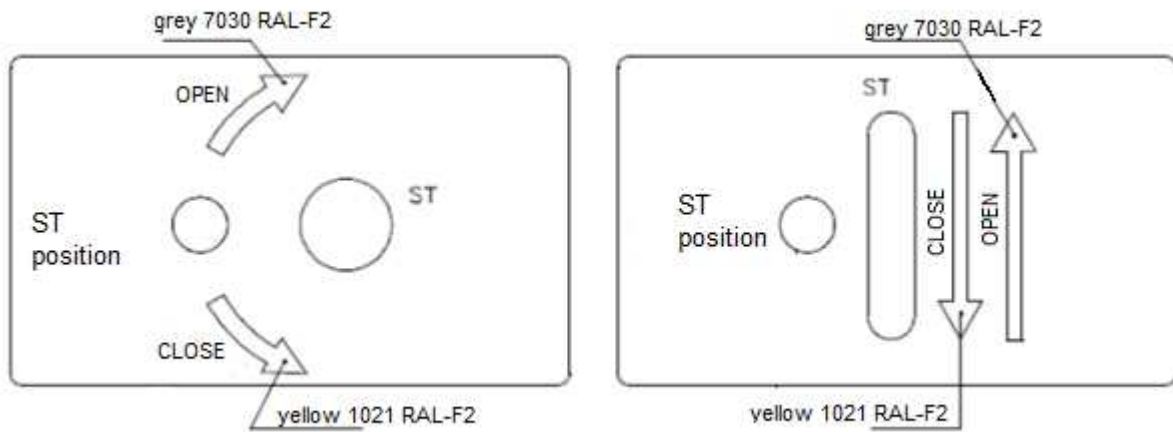
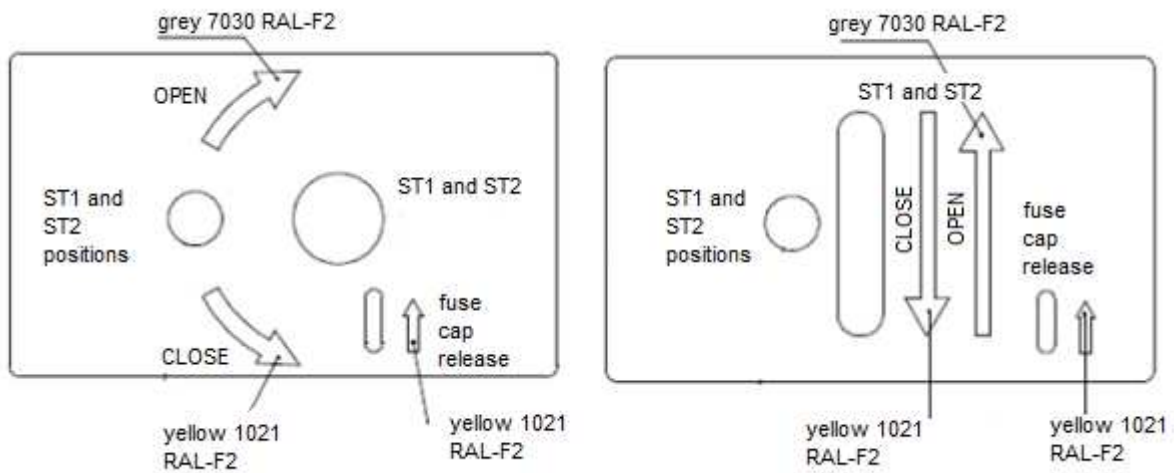

Figure 9: Operating devices of the switch-disconnector (IMS)

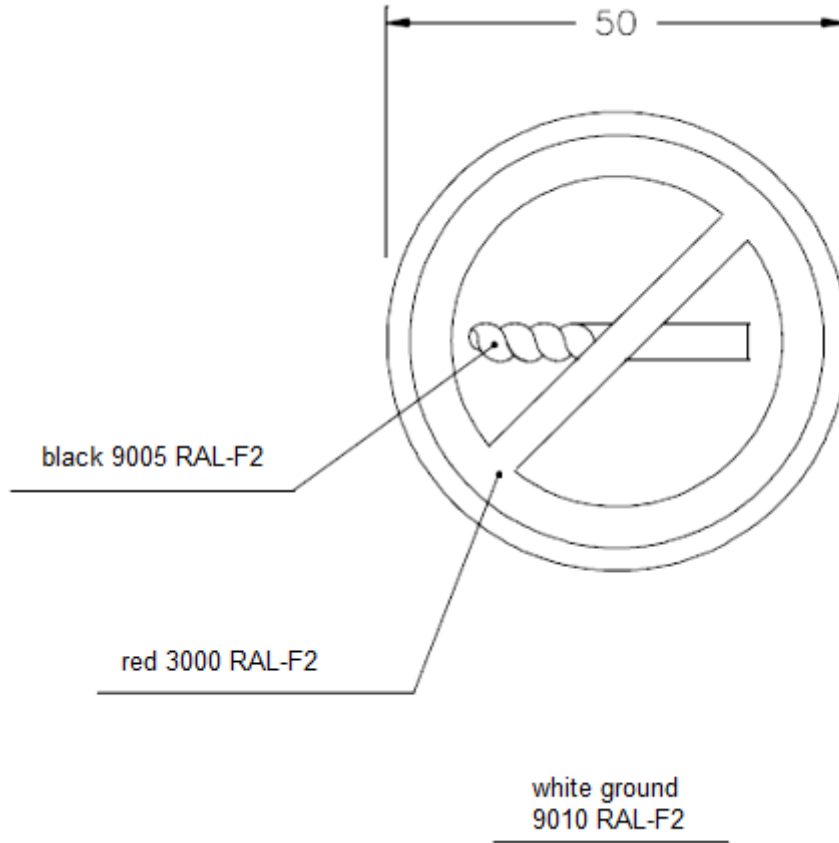

**Figure 10: Operating devices of line earthing switches (ST)**

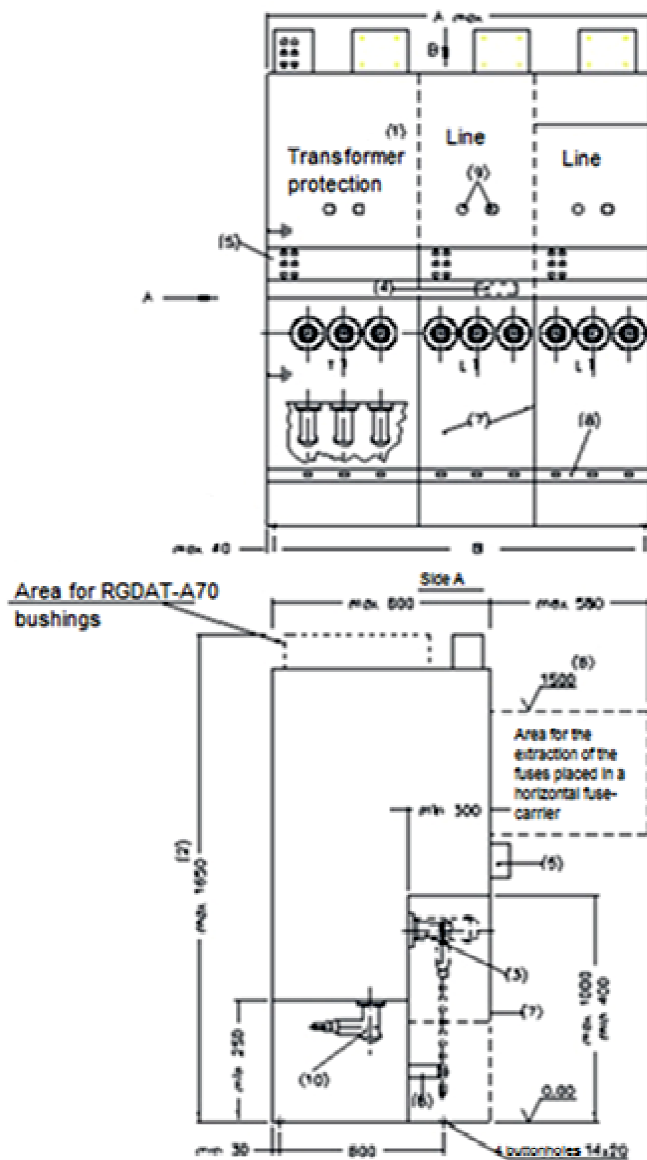

**Figure 11: Operating devices for transformer protection earthing switches and for fuse-cover release (ST<sub>1</sub>, ST<sub>2</sub>)**

	GLOBAL STANDARD	Page 47 of 52
	MV RMU WITH SWITCH-DISCONNECTOR	GSM001 Rev. 00 10/07/2014

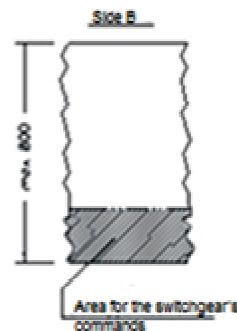

**Figure 12: Warning nameplate for the switchgear drilling**



Type code	A max [mm]	B [mm]
GSM001/1	1400	1000-1150
GSM001/2	1750	1000-1150
GSM001/3	1400	1000-1150
GSM001/4	2100	1000 1600
GSM001/5	1750	1000-1600

Type code	Height [mm]	Depth [mm]	Width [mm]	
			Line	Tr
GSM001/6	1800	800	400	520
.....				
GSM001/25	2000	1100	450	600
.....				
GSM001/45				



- (1) Preferential position of the transformer protection upright (the fuse-carrier can be placed in a horizontal or vertical way)
- (2) The maximum height also includes the size for the extraction of the fuses placed in vertical fuse-carrier, the support for RGDAT and busbar voltage detecting system
- (3) External cone type insulators for line and transformer protection uprights (EN 50181)
- (4) Preferential position for the valve against overpressure
- (5) Panel for the fixing of the voltage detecting system (approximate position)
- (6) Maximum size for the extraction of the fuses placed in a horizontal fuse-carrier
- (7) Metallic panels for the MV cable terminals segregation (it shall be ensured at least IP3X)
- (8) Support for the fixing of MV cables
- (9) Operating devices of the switch-disconnector and earthing switch (approximate position)
- (10) Termination for transformer protection upright (as an alternative to the preferential termination on the frontal side)

Figure 13: Example of frontal view and maximum dimensions



 	GLOBAL STANDARD	Page 49 of 52
	MV RMU WITH SWITCH-DISCONNECTOR	GSM001 Rev. 00 10/07/2014

## ANNEX B

Type code	Edesur	Ampla	Coelce	Chilectra	Codensa	Enel Distribuz.	Edelnor	Enel Distributie	Endesa D.E.
GSM001/1						16 21 16		16 21 16	
GSM001/2						16 21 17		16 21 17	
GSM001/3						16 21 18		16 21 18	
GSM001/4						16 21 19		16 21 19	
GSM001/5						16 21 20		16 21 20	
GSM001/6									6711041
GSM001/7									6711043
GSM001/8									6711042
GSM001/9									
GSM001/10									6711067
GSM001/11									6711045
GSM001/12									6711047
GSM001/13									6711046
GSM001/14									
GSM001/15									6711068
GSM001/16									6711071
GSM001/17									6705307
GSM001/18									6711049
GSM001/19									6711048
GSM001/20									6711050
GSM001/21									6705302
GSM001/22									6703479
GSM001/23									6711052
GSM001/24									6711051
GSM001/25									6703471
GSM001/26									6703472

 	GLOBAL STANDARD	Page 50 of 52
	MV RMU WITH SWITCH-DISCONNECTOR	GSM001 Rev. 00 10/07/2014

Type code	Edesur	Ampla	Coelce	Chilectra	Codensa	Enel Distribuz.	Edelnor	Enel Distributie	Endesa D.E.
GSM001/27									6711053
GSM001/28									6711055
GSM001/29									6711054
GSM001/30									6711069
GSM001/31									6711057
GSM001/32									6711059
GSM001/33									6711058
GSM001/34									6711070
GSM001/35									6711072
GSM001/36									6705305
GSM001/37									6711061
GSM001/38									6711060
GSM001/39									6711062
GSM001/40									6705301
GSM001/41									6703480
GSM001/42									6705681
GSM001/43									6705679
GSM001/44									6703473
GSM001/45									6703474

	GLOBAL STANDARD	Page 51 of 52
	MV RMU WITH SWITCH-DISCONNECTOR	GSM001 Rev. 00 10/07/2014

### ANNEX C

This form is used for evaluating the offer in the tender process and also for the technical data validation during the homologation, certification and approval procedure.

Flag here the use of this form:

Offer in the Tender

Technical Data Validation

This document has to be used for checking the compliance of the RMU during the tender process.

Deviations are in principle not acceptable.

Possible deviations have to be clearly reported in the following form for specific deviations.

The acceptance of this document for the next tender stage does not mean the acceptance of any deviation to the technical specification if such deviations are not clearly reported in the form for specific deviations.

	GLOBAL STANDARD	Page 52 of 52
	MV RMU WITH SWITCH-DISCONNECTOR	GSM001 Rev. 00 10/07/2014

**FORM FOR SPECIFIC DEVIATIONS**

Each specific deviation shall be reported and explained here below (to be indicated with a progressive number).

NO DEVIATIONS

(to flag in case of no deviations from the Global Standard)

**DEVIATION 1**

[To indicate possible Deviation

.....  
.....  
.....  
.....  
.....  
.....]

**DEVIATION 2**

[To indicate possible Deviation

.....  
.....  
.....  
.....  
.....  
.....]

**DEVIATION ...**

[To indicate possible Deviation

.....  
.....  
.....  
.....  
.....  
.....]

Date [.....]

Sign [.....]